



APPLICATION NOTE 2140

## Examples Using the DS3930 as Voltage References and Digital I/O

*Abstract: The DS3930 contains six 256-position nonvolatile potentiometers, which makes the DS3930 an ideal device for applications needing multiple voltage references. The DS3930 also has four general-purpose, nonvolatile I/O pins that can monitor a digital input or supply a digital output. This application note provides examples using the DS3930 as a voltage reference and digital I/O.*

### Introduction

The DS3930 contains six 256-position nonvolatile (NV) potentiometers (see **Figure 1**), which makes the DS3930 an ideal device for applications needing multiple voltage references. All six potentiometers share a common low side. The potentiometers are separated into two groups of three 50k $\Omega$  potentiometers in parallel. Each group of three shares a common high side. The potentiometer wiper voltage can vary between 0V and  $V_{HI}$  in 256 steps, where  $V_{HI}$  is the voltage on HI<sub>0-2</sub> or HI<sub>3-5</sub>.

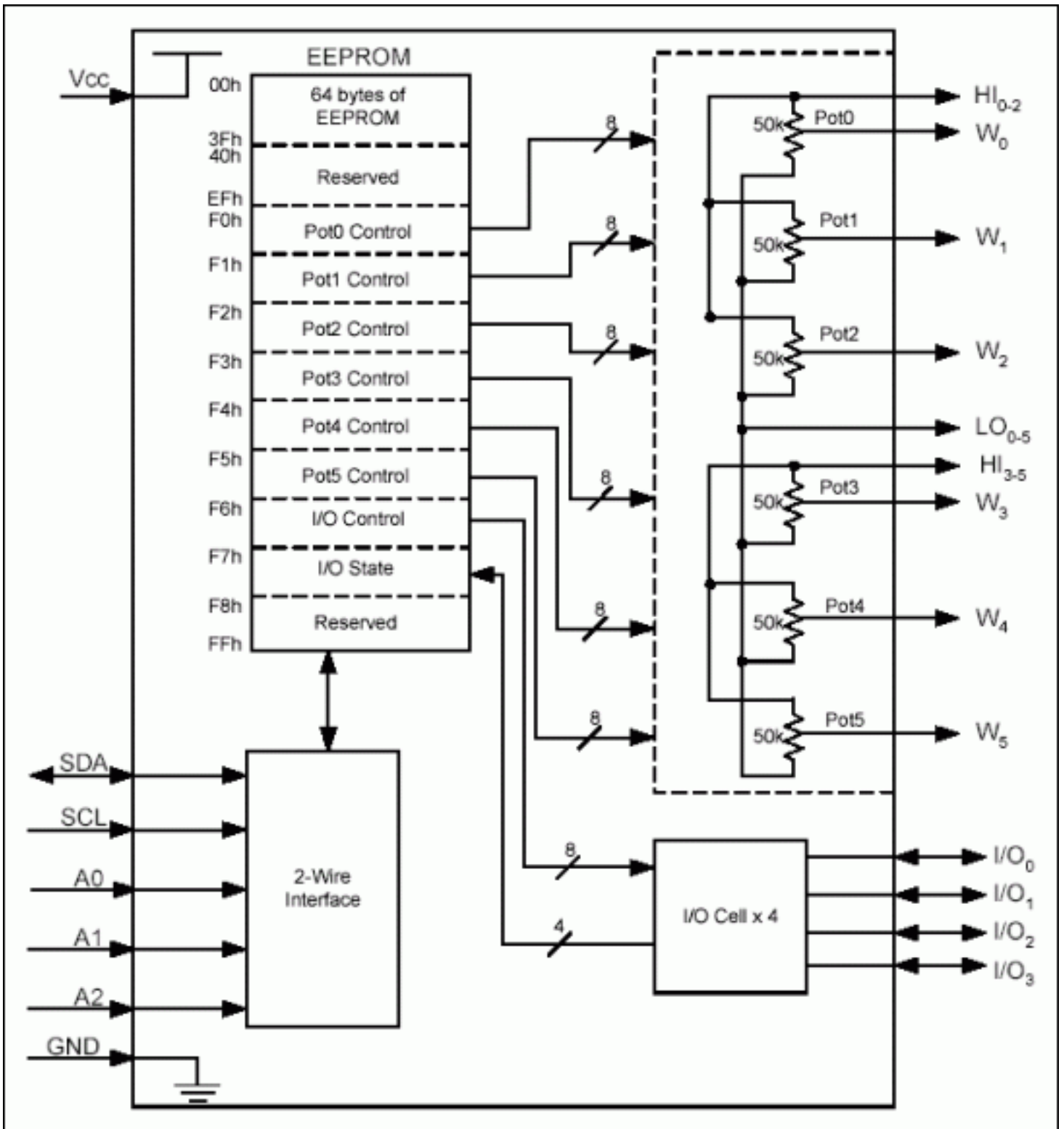

Figure 1. DS3930 block diagram.

The DS3930 also has four general-purpose, NV I/O pins. These pins can be configured as inputs or outputs. When configured as an input, a voltage can be applied to the I/O pin, then the state of the pin can be monitored with an internal register through the 2-wire interface. When the I/O pin is configured as a digital output, the output state can be internally set either high or low.

This application note provides examples using the DS3930 as a voltage reference and digital I/O.

## Voltage Reference

The potentiometers can be configured as voltage references to provide a variable or constant voltage. The high side (HI<sub>0-2</sub> or HI<sub>3-5</sub>) and the low side (LO<sub>0-5</sub>) should be tied to a voltage between ground and 5.5V (max V<sub>CC</sub>).

Typically, the high side is tied to a power supply and the low side is tied to ground. Each potentiometer has 256 positions to provide fine adjustment of the wiper voltage with registers F0h-F5h. With the high side tied to 5V, for example, each step would change the wiper voltage 19.6mV from 0V to 5V. If the high side is tied to a 3.3V supply, each step is 12.94mV.

When configuring the DS3930 for an application, the circuit should be designed so the current through the wiper is constant and close to 0mA, to produce a more accurate and stable voltage, and does not exceed  $\pm 1$ mA. Also, with the potentiometer configured as a voltage reference (ratiometric), the output is more accurate over temperature compared to using the potentiometer in an end-to-end configuration. The ratiometric temperature coefficient is typically 2 ppm/°C.

## Digital I/O

The I/O pins can be configured as digital inputs or outputs. To configure an I/O pin as an input, set Pullup Ctrl and Pin Setting (see Table 1) to 1 (I/O pin output = HI-Z), and apply a voltage between 0V and V<sub>CC</sub> + 0.5 to the I/O pin. The state of the input can then be monitored in register F7h. To configure an I/O pin as an output, set Pullup Ctrl and Pin Setting to a high or low depending on the desired output, and float the I/O pin. Table 1 shows how to set the I/O Control register (F6h) to control the I/O pin's output.

**Table 1. I/O Pin Truth Table**

Pullup Ctrl (I/O Control Register, bits 7:4)	I/O Pin Setting (I/O Control Register, bits 3:0)	I/O Pin Output
0	0	0
0	1	1
1	0	0
1	1	HI-Z

## Design Example

The following example shows how to configure the potentiometer's wipers as voltage references and the I/O pins as digital inputs and outputs. **Figure 2** shows how to design a sample application circuit.

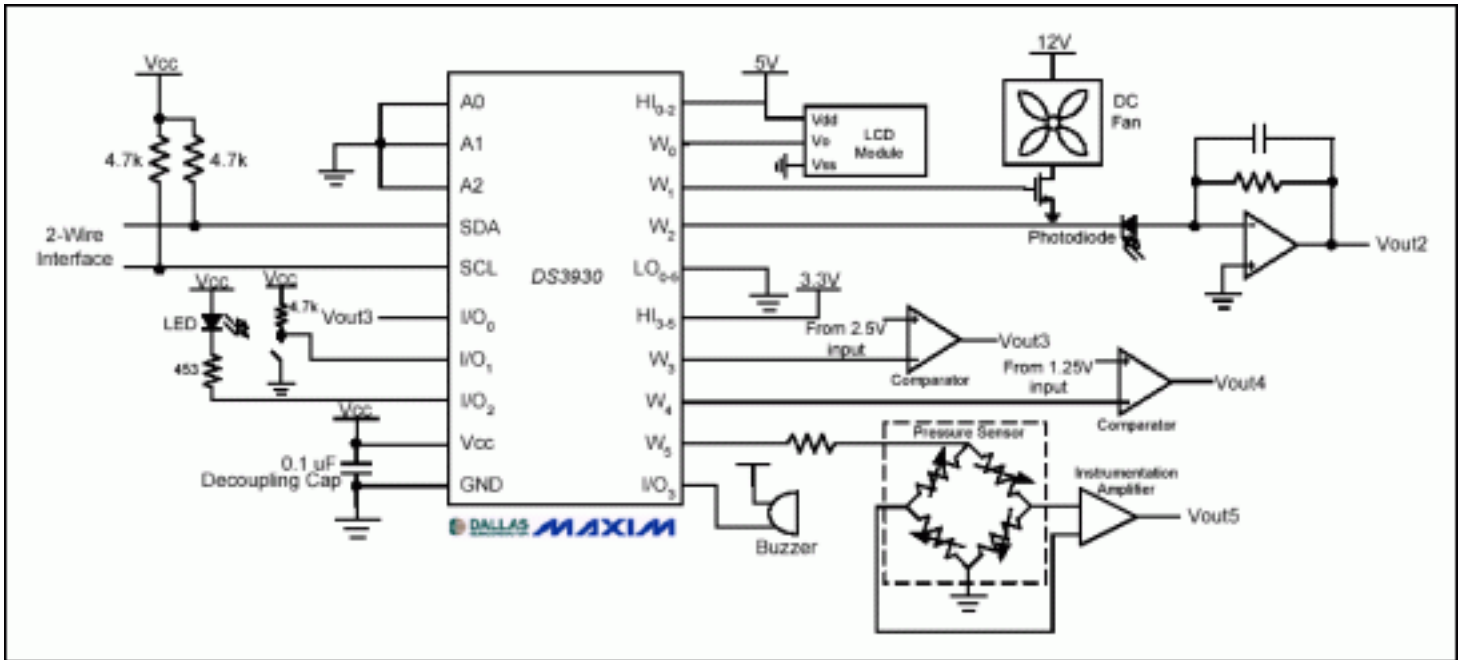

Figure 2. DS3930 circuit.

In the sample application circuit, the high side of potentiometers 0-2 ( $HI_{0-2}$ ) is connected to 5V, and the high side of potentiometers 3-5 ( $HI_{3-5}$ ) is connected to 3.3V.  $W_0$  is used to control a LCD, and  $W_1$  controls the speed of a fan.  $W_2$  provides the  $V_{bias}$  for a photodiode.  $W_3$  and  $W_4$  go into a comparator to determine if the reference voltage goes above/below the set value.  $W_5$  provides the  $V_{bias}$  for a pressure sensor. See Table 2 for the potentiometer registers and their settings for this example.

Table 2. Voltage References

Wiper	Voltage (V)	Address (hex)	Example Setting (hex)	Application
0	5.0	F0	FF	LCD
1	2.5	F1	80	Fan
2	5.0	F2	FF	Photodiode
3	2.5	F3	C2	Comparator
4	1.25	F4	61	Comparator
5	3.3	F5	FF	Pressure Sensor

Figure 3 shows how to set each bit in the I/O Control register (F6h) for this example. I/O pins 0 and 1 are set as inputs and I/O pins 2 and 3 are set as outputs ( $I/O_2 = \text{low}$ ,  $I/O_3 = \text{high}$ ). Since  $I/O_0$  is an input, the Pullup Ctrl bit should be set high (bit 0), and the I/O Pin Setting bit should be set high (bit 4).  $I/O_2$  is a high output, therefore, bit 7 should be low, and bit 3 should be high.

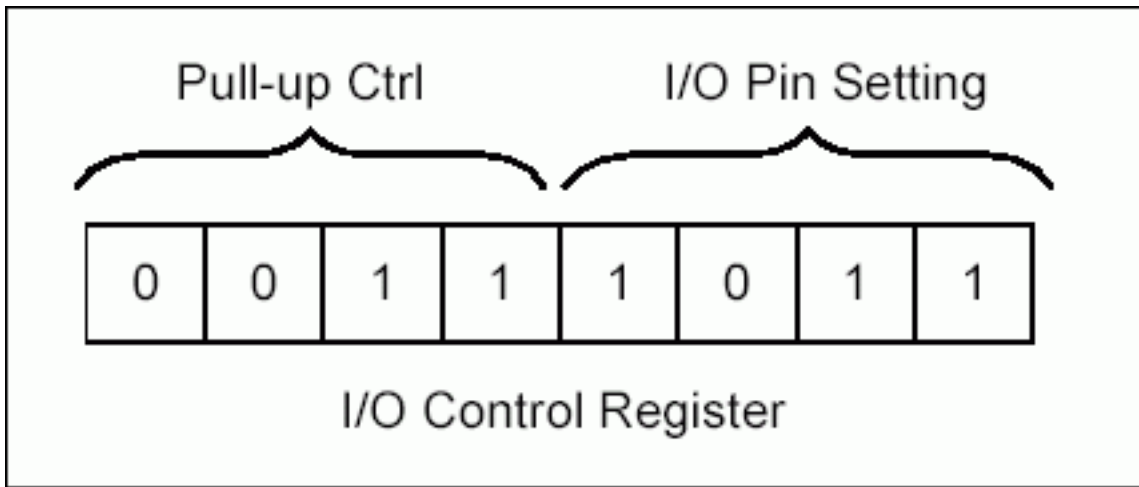

Figure 3. I/O control register configuration.

I/O<sub>0</sub> and I/O<sub>1</sub> are configured as inputs. The I/O<sub>0</sub> input signal monitors Vout3. If the external 2.5V input is above the 2.5V set value from the potentiometer, Vout3 (and I/O<sub>0</sub>) is high. If the external 2.5V input is below the 2.5V value of the potentiometer, Vout3 (and I/O<sub>0</sub>) is low. The I/O<sub>1</sub> input monitors a switch circuit. The application software can be configured to set a flag if the voltage goes to 0V or V<sub>CC</sub>.

I/O<sub>2</sub> and I/O<sub>3</sub> are configured as outputs. I/O<sub>2</sub> controls an LED and I/O<sub>3</sub> controls a buzzer with a built-in self-drive circuit. I/O<sub>2</sub> is set to output a low so the LED will be on. The buzzer will be off since I/O<sub>3</sub> is set to output a high.

## Conclusion

There are unlimited applications where voltage references and digital I/Os can be used. This application note provides a few examples on how to interface the potentiometer wipers and I/O pins to different types of circuits. For more information on the DS3930, refer to the [datasheet](#). For applications support, contact [MixedSignal](mailto:Apps@dalsemi.com). [Apps@dalsemi.com](mailto:Apps@dalsemi.com).

---

Application Note 2140: <http://www.maxim-ic.com/an2140>

### More Information

For technical questions and support: <http://www.maxim-ic.com/support>

For samples: <http://www.maxim-ic.com/samples>

Other questions and comments: <http://www.maxim-ic.com/contact>

### Related Parts

DS3930: [QuickView](#) -- [Full \(PDF\) Data Sheet](#) -- [Free Samples](#)

AN2140, AN 2140, APP2140, Appnote2140, Appnote 2140

Copyright © by Maxim Integrated Products

Additional legal notices: <http://www.maxim-ic.com/legal>