



Keywords: RS-485, rs485, full duplex, isolated, isolation, isolated circuits, isolated lines, 250kbaud, 2.5Mbaud, 250 kilobaud, 2.5 megabaud, bi-directional, 1600V isolation, 2000V isolation, transformer coupled, opto coupled, optocouplers, internal isolated Jul 09, 1998

APPLICATION NOTE 2116

RS-485 Data Interface Gives Isolated, Full-Duplex Operation

Abstract: A circuit is described that provides fully isolated RS-485 full-duplex data communication with only two integrated circuits (ICs). An internal transformer-coupled isolated supply and internal optocouplers in the data path provide typical isolation to 1600Vrms for 1 minute or 2000Vram for 1 second. Data rates of 250kbaud are achieved with internally slew-rate-limited circuits or to 2.5Mbaud with non-slew-rate limited circuits, depending upon choice of available ICs.

The simple RS-485 circuit of **Figure 1** provides full-duplex communications (simultaneous transmission and reception) with only two essential packages (IC2 and IC3). Its balanced and differential data lines are necessary for high-noise environments or for long-distance transmission between a computer and its peripherals. Such transmissions are difficult, if not impossible, with the single-ended circuitry of an RS-232 transceiver.

The RS-485 standard allows for bidirectional, multi-point, party-line communications, with data rates to 10M bits/second (10Mbps) and line lengths to 1200 meters. Differential transmission provides noise immunity. The circuit shown features controlled-slew-rate drivers that minimize EMI and the reflections caused by improperly terminated cables. It also enables error-free transmissions to 250kbps. To achieve data rates to 2.5Mbps, substitute a full-slew-rate MAX1480A for IC2, a MAX485 for IC3, and R2—R5 values per **Table 1**.

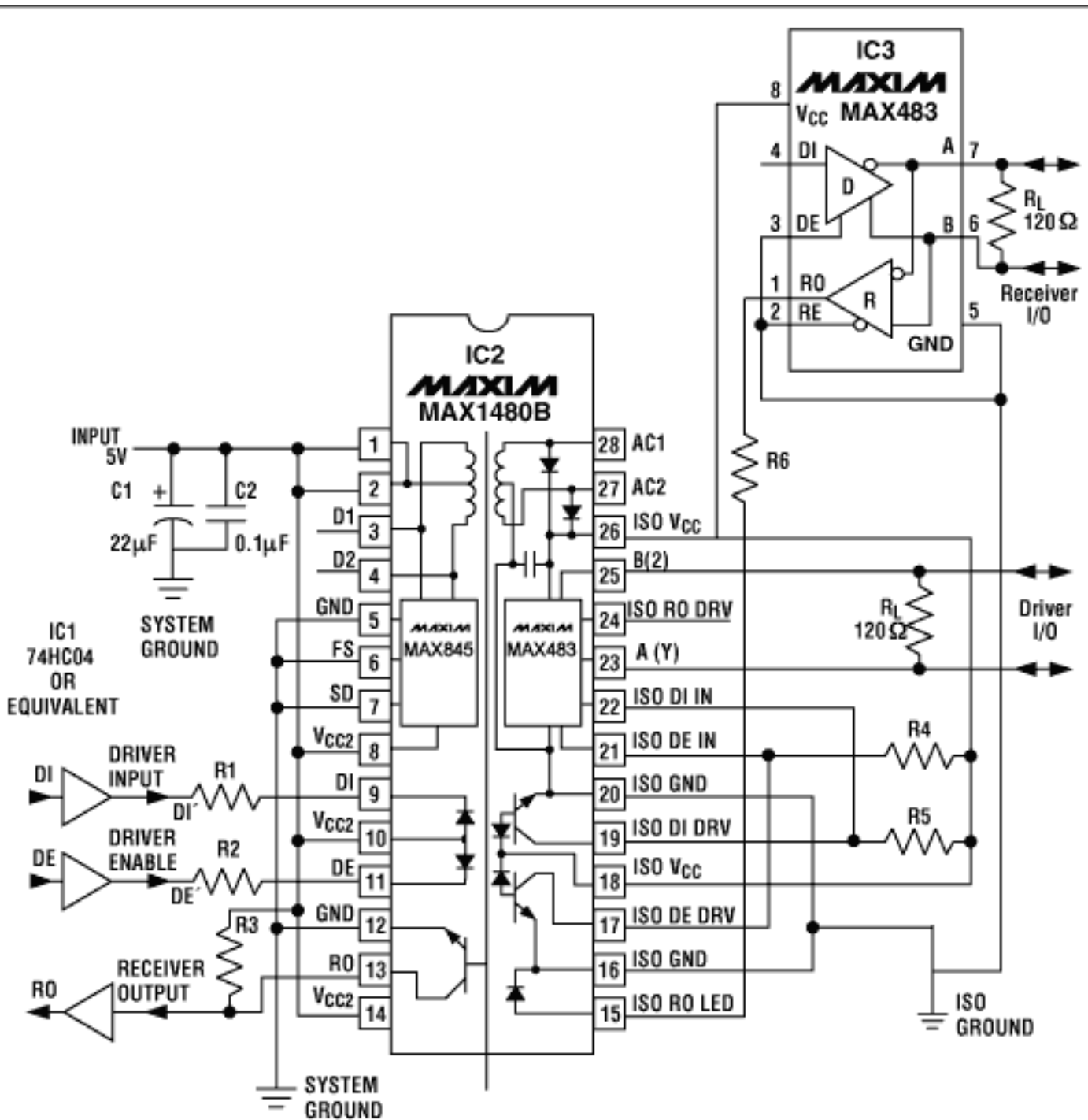

TABLE 1. PULL-UP AND LED DRIVE RESISTORS

IC2	IC3	R1(Ω)	R2(Ω)	R3(Ω)	R4(Ω)	R5(Ω)	R6(Ω)	MAX DATA RATE
MAX1480A	MAX485	200	200	360	3k	360	200	2.5Mbps
MAX1480B	MAX483	200	510	3k	22k	3k	200	250kbps

Figure 1. IC2 and IC3 provide full-duplex data communications for cable lengths as long as 1200 meters.

IC2 is a complete half-duplex interface that includes transceivers, optocouplers, a power driver, and a transformer. The optocouplers transmit digital signals across the internal isolation barrier, and the center-tapped transformer transmits power across the barrier from its logic (non-isolated) side to its isolated side.

IC3, powered by the isolated V_{CC} , upgrades the half-duplex operation of IC2 to full duplex using IC2's own dedicated optocouplers. Pin 3 must be tied low to disable IC3's driver, and pin 4 should be left floating. The driver outputs for IC2 and IC3 exhibit high impedance when active-low DE is low; bringing active-low DE high enables the outputs to function as line drivers.

The isolation barrier in IC2 typically withstands $1600V_{rms}$ for one minute or $2000V_{rms}$ for one second. Any TTL/CMOS-logic family can drive the IC2 digital inputs through a series resistor. With resistive pull-ups, the receiver outputs can drive any such logic as well. IC2's isolated outputs meet all RS-485 specifications.

Application Note 2116: <http://www.maxim-ic.com/an2116>

More Information

For technical questions and support: <http://www.maxim-ic.com/support>

For samples: <http://www.maxim-ic.com/samples>

Other questions and comments: <http://www.maxim-ic.com/contact>

Related Parts

MAX1480A: [QuickView](#) -- [Full \(PDF\) Data Sheet](#)

MAX1480B: [QuickView](#) -- [Full \(PDF\) Data Sheet](#)

MAX253: [QuickView](#) -- [Full \(PDF\) Data Sheet](#) -- [Free Samples](#)

MAX483: [QuickView](#) -- [Full \(PDF\) Data Sheet](#) -- [Free Samples](#)

MAX483E: [QuickView](#) -- [Full \(PDF\) Data Sheet](#) -- [Free Samples](#)

MAX485: [QuickView](#) -- [Full \(PDF\) Data Sheet](#) -- [Free Samples](#)

MAX485E: [QuickView](#) -- [Full \(PDF\) Data Sheet](#) -- [Free Samples](#)

AN2116, AN 2116, APP2116, Appnote2116, Appnote 2116

Copyright © by Maxim Integrated Products

Additional legal notices: <http://www.maxim-ic.com/legal>