

Design Note:

HFDN-26.0

Rev.1; 04/08

**MAX3735A Laser Driver Output Configurations,
Part 1: DC-Coupled Optimization Techniques**



Maxim Integrated Products



MAX3735A Output Configurations, Part 1: DC-Coupled Optimization Techniques

1 Introduction

The MAX3735A is a DC-coupled SFP laser driver designed for data rates up to 2.7Gbps (reference [1](#)). The multi-rate capability, small package, APC loop, SFP safety/timing specifications and monitor outputs of the MAX3735A make it suitable for a large variety of optical module applications operating over a wide range of data rates.

This design note (Part 1 of a series of notes) will discuss the DC-coupled interface in detail (Refer to reference [2](#) for a basic description of the DC-coupled interface). The output of the MAX3735A is intended to drive DC-coupled, edge-emitting, common-anode lasers, but it can also drive AC-coupled and differentially driven, edge-emitting lasers. The MAX3735A can also be configured to drive common-anode VCSELs.

The other output configurations will be detailed in future parts of this design note series on coupling interfaces. The purpose of these notes is to discuss the advantages and disadvantages of the various output configurations, and to provide schematics and examples that will help module designers choose the optimal output structure for their application.

The MAX3735A will be used as an example to discuss these interfaces, but the techniques can be applied to other laser drivers such as the MAX3737, MAX3735, MAX3850 and MAX3656, due to their similar output structures.

2 DC-Coupled Interfaces

With advancements in high-speed laser driver output structures, the MAX3735A (and other drivers mentioned previously) offer the capability of DC coupling a laser to the driver at +3.3V supply voltages. Until recently this has not been possible due to the required compliance voltages at the output pins (reference [2](#)). The MAX3735A can maintain

proper high-speed performance when the instantaneous output voltage is above 0.7V. Given the very low headroom requirement (0.7V), modulations currents of approximately 60mA can be obtained (assuming a 15Ω load) with the DC-coupled interface using a +3.3V supply. The maximum attainable modulation current can be calculated using the following equation:

$$I_{MOD}(Max) = \frac{V_{CC}(Min) - V_{LF}(Max) - 0.7}{R_{LOAD}}$$

Where V_{LF} is the maximum forward voltage-drop of the laser, $V_{CC}(Min)$ is the minimum supply voltage and R_{LOAD} is the impedance of the laser plus any series resistance.

2.1 DC-Coupled Advantages

1. **Multi-Rate Compatible** – The DC-coupled output accommodates a wide modulation frequency range. AC-coupled lasers will have a low frequency cut-off that can affect the performance due to baseline wander (reference [3](#)).
2. **Fewer Components** – A DC-coupled output requires only two to four external components to interface with a laser, while an AC-coupled interface can require six to 12 external components for the interface.
3. **Simple Matching** – Since there are fewer components required, there are less variables and parasitic values that need to be accounted for when matching the laser to the driver.
4. **Low Power** – The DC-coupled interface allows for lower bias currents because the modulation current contributes to the average power output.

5. **Versatile** – The low compliance voltage allows for versatility in design allowing one part to be used with multiple lasers and multiple output configurations. (i.e. the MAX3735A can be AC or DC coupled while an AC-coupled laser driver can only be AC coupled.)

2.2 DC-Coupled Disadvantages

1. **Modulation Current Range** – Up to 60mA of modulation current is possible when using the MAX3735A DC coupled. Applications that require larger modulation currents should be AC coupled. (Note: The MAX3735A can deliver up to 85mA when AC coupled.)
2. **Lower Load Impedance** – The MAX3735A is intended to drive a 15Ω load when DC coupled. Some lasers have built in resistors that increase the load to 25Ω. For these lasers, modulation current less than 40mA or AC-coupled interfaces should be used.

3 Special Considerations / Layout Techniques

To obtain good results at high data rates with a DC-coupled laser, variables such as the laser package, component placement, return path and filtering should be carefully evaluated. See reference 5 for a detailed example of a complete SFP module layout that uses the techniques mentioned below.

3.1 Laser Package and Lead Length

The inductance and capacitance in the modulation path should be reduced as much as possible when modulating laser diodes at high data rates. Parasitic inductance and capacitance of the laser and external components will decrease edge speeds, which can lead to increased jitter. Given that DC-coupled interfaces have fewer external components than AC-coupled lasers, this process is simplified. However, care should still be taken to account for parasitic inductance and capacitance for all of the components in the output signal path.

Using short connections from the laser driver to the laser, short leads (for a TO-style package) or improved laser packages will reduce the series

inductance. Also, the bandwidth of the package can be increased and inductance reduced by using simple external modification on some types of lasers. For example, when the laser anode is connected to the case, a solder bead can be placed on the photodiode cathode lead to connect it to the case as well. (See Figure 1. Note: Care should be taken to not exceed manufacturers soldering limits when modifying the laser.)

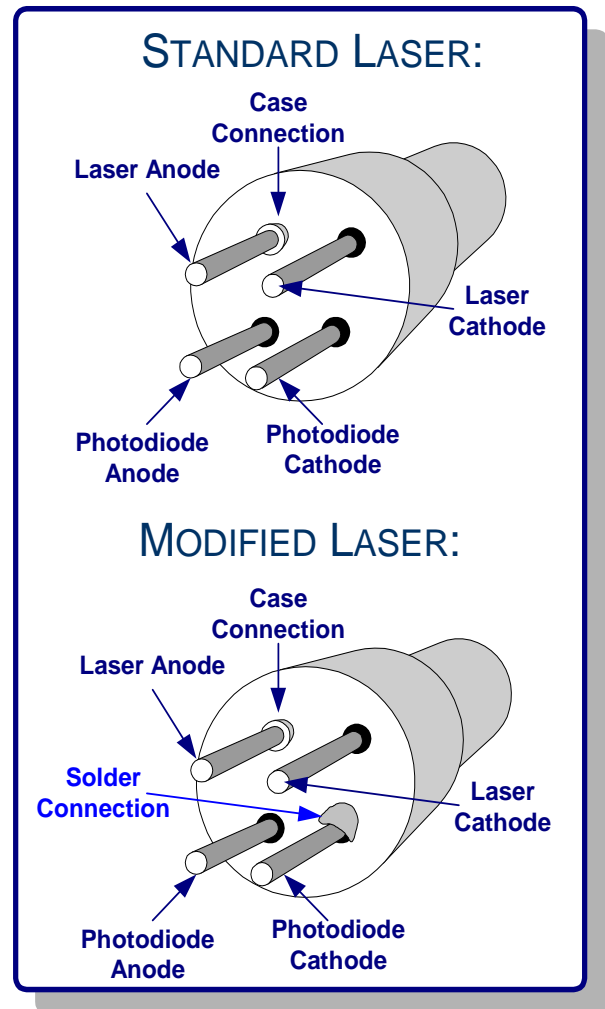

Figure 1. Laser Case Modification.

Since the laser anode and photodiode cathode are both externally connected to the same potential, the modification reduces the effective lead inductance by allowing two connections to the laser case. As seen in Figures 2 and 3, the modified case improves the filtered optical rising and falling edges by 14.9ps and 17.2ps respectively. (Note: The laser pin-out shown in Figure 1 is not required for DC-coupled drivers. Other lasers pin-outs also work well.)

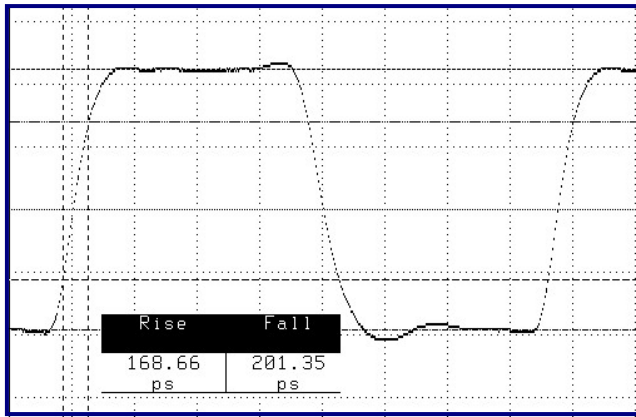

Figure 2. Optical Rise and Fall Times Without Case Modification.

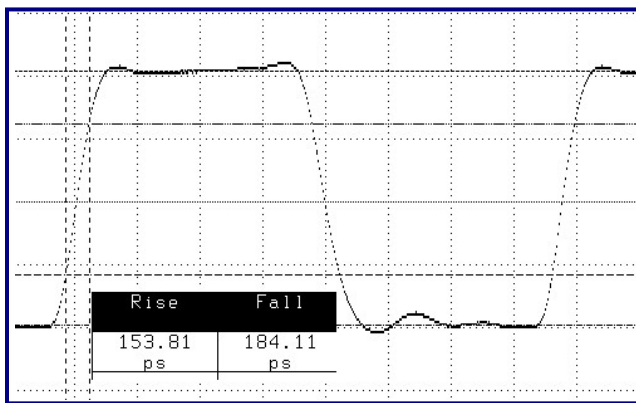

Figure 3. Optical Rise and Fall Times With Case Modification.

3.1.1 Edge Mounting the Laser

It is common in circuit board design to pull the ground and power plane back from the physical edge of the board. But, when connecting a TO-style laser to the edge of the board, the ground plane should extend to the edge of the board that interfaces with the laser (Figure 4). Extending the ground plane will reduce the inductance of the leads and improve the high-speed performance. If possible, the high-speed connections (laser anode and cathode) should be placed on the top of the circuit board to take advantage of the lower lead inductance created by the extended ground plane. The laser should also be mounted as close as possible to the edge of the board to reduce the inductance of the leads.

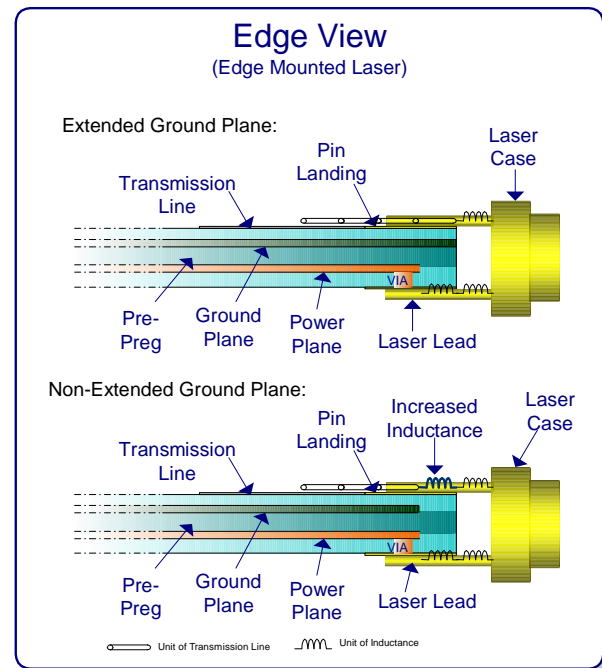

Figure 4. Edge View of an Edge Mounted Laser

3.2 Schematics

The schematic connections of the output network are shown in Figure 5. In this figure, the node connection VLD (voltage at the laser diode) is highlighted. R1 and D1 are terminated to the same node to improve the matching of the differential pair output. More on this will be discussed in section 3.4. The schematic should be adjusted depending on the properties of the laser, but can be used as a reference.

The components C4, R3, R2 and D1 combine to form the AC load seen by the OUT+ pins. The purpose of C4 and R3 is to match the output by reducing the peaking of the laser output that can be caused by the laser lead inductance (reference 2). C4 and R3 should be determined experimentally, but will often range from 2pF to 8pF (C4) and 50Ω to 75Ω (R3) for coaxial TO header type lasers. C1 should also be determined according to the properties of the laser (reference 4).

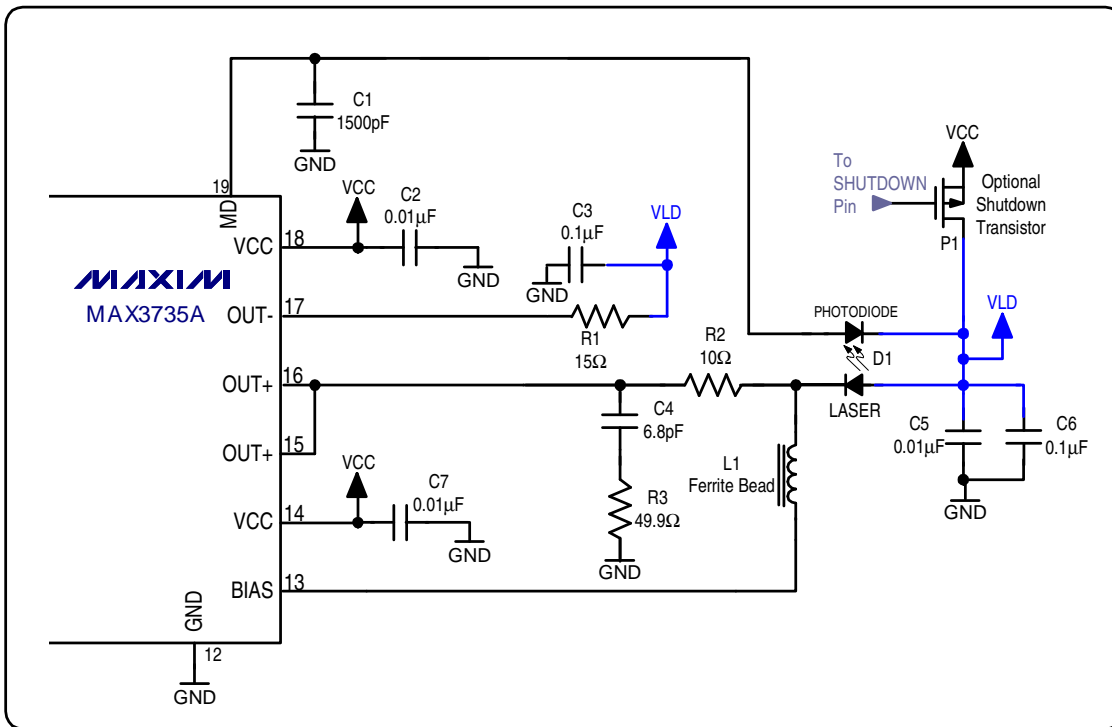

Figure 5. Schematic of output structure.

3.3 Component Placement

For the MAX3735A, the laser should be placed close to the outputs when using a DC-coupled output structure. Creating transmission lines to match a 15Ω load can be difficult. By placing the laser close to the driver, transmission line geometry can be neglected as long as the length of the connection is small compared to the wavelength that is expected to propagate down the line. For FR-4 material and the 2.7Gbps data rates being used, this length should be less than about 6 or 7mm. If the distance is small compared to the wavelength, the trace width can then be reduced which will lower the parasitic capacitance on the output.

The small number of external components required for a DC-coupled interface facilitates the placement of the laser close to the driver. Using Figure 5 as a reference, a possible component placement is shown in Figure 6. (Note: These configurations are suggestions only and should be evaluated and modified as necessary.)

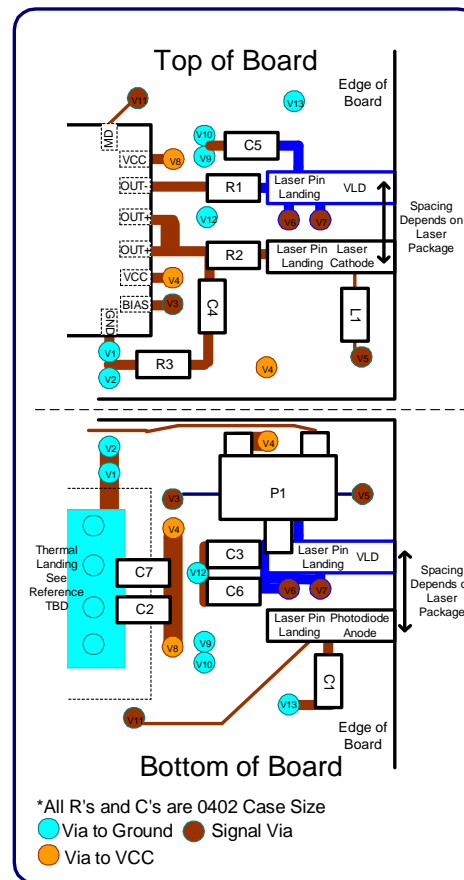

Figure 6. Possible Component Placement

3.4 Return Path and Filtering

An important part of component placement is to properly evaluate the return path, current flow and filtering. Dedicated ground and power planes should be used. Using dedicated planes will lower the connection impedance and provide a better return path for the high-speed currents.

To improve performance, the flow of current in the high-speed path should also be carefully evaluated. As seen in the Figure 5, R1 and D1 are terminated to the same potential. Terminating the two connections physically close to each other can improve the current flow in the high-speed path. By terminating R1 and D1 to the same point (Figure 6) the current draw from the node will have more direct current and less switching current. It can also help to close the loop of the current path and reduce EMI.

The VCC and high-speed termination points should be well bypassed. The VLD node, for example, should have sufficient bypass capacitance to minimize supply ripple due to high-speed current switching. The return path of the bypass capacitors should also be oriented (if possible) so the ground connection is close to the transmission line and the ground of the device.

4 Example

Applying the suggestions above, the following optical eye diagrams were obtained using the MAX3735A DC coupled to the SLT2170-LN edge-emitting laser manufactured by ExceLight (reference [6](#)). See reference [5](#) for more details regarding the exact layout and components used to obtain the eye diagrams shown below.

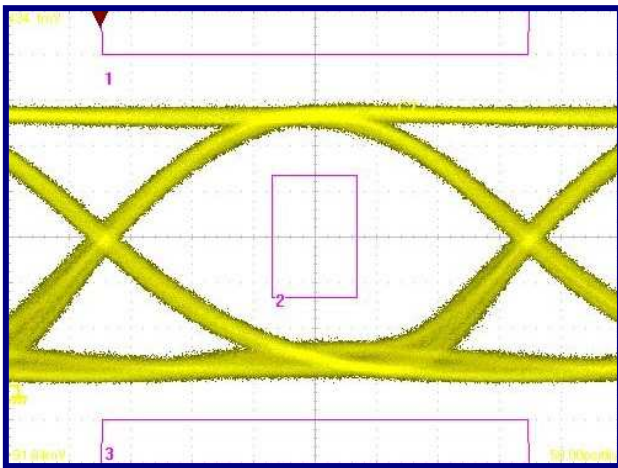

Figure 7. OC48 (Filtered), $E_R = 10\text{dB}$, 2^{23}-1PRBS

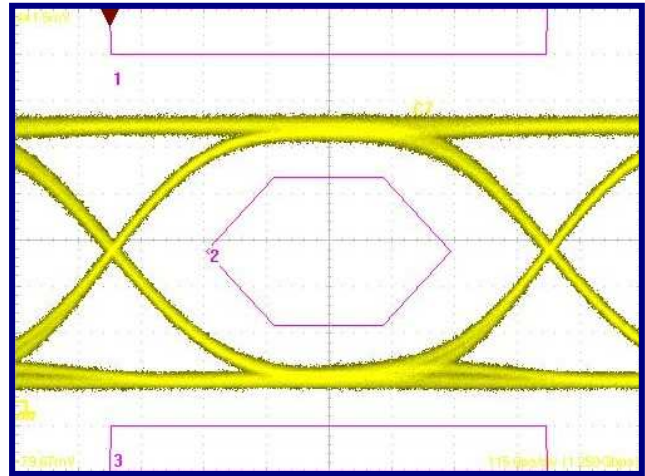

Figure 8. 1.25Gbps (Filtered), $E_R = 10.5\text{dB}$, 2^7-1PRBS

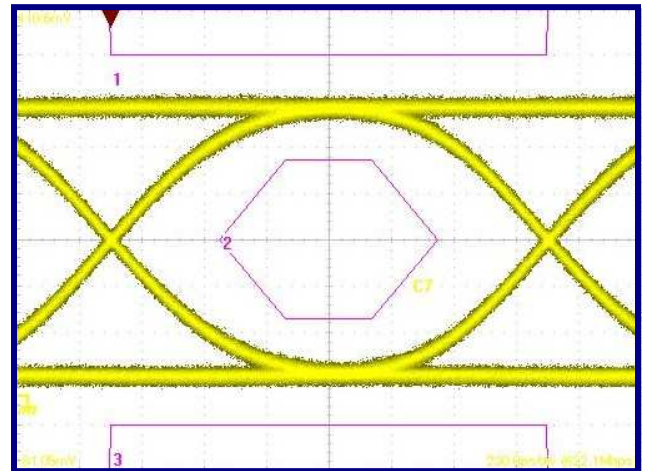

Figure 9. OC12 (Filtered), $E_R = 11.1\text{dB}$, 2^{23}-1PRBS

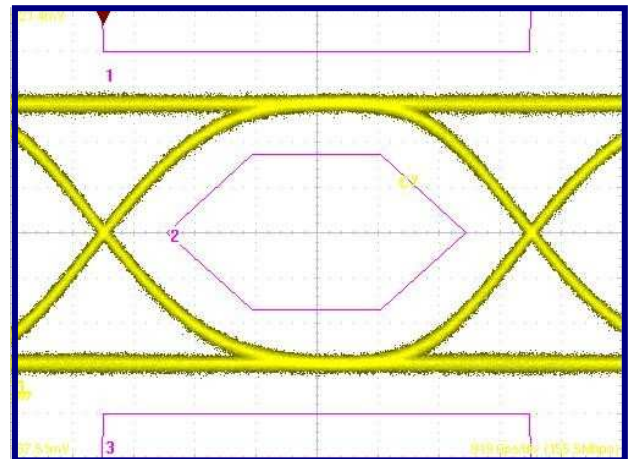

Figure 10. OC3 (Filtered), $E_R = 11.7\text{dB}$, 2^{23}-1PRBS

5 Conclusion

The DC-coupled optical interface of the MAX3735A has advantages that make it ideal for many applications including multi-rate applications. By applying the methods discussed, good optical performance can be obtained for multiple data rates using a DC-coupled interface.

6 References:

1. Data Sheet: “MAX3735/MAX3735A: 2.7Gbps, Low Power SFP Laser Driver.” - [Maxim Integrated Products](#), May 2003.
2. Application Note: “[Interfacing Maxim Laser Drivers with Laser Diodes.](#)” – HFAN-02.0, Maxim Integrated Products, December 2003.
3. Application Note: “[NRZ Bandwidth – LF Cutoff and Baseline Wander](#)” – HFAN-09.0.4, Maxim Integrated Products, September 2002.
4. Design Note: “[Choosing the APC Loop Capacitors Used in MAX3735/MAX3735A SFP Module Designs](#)” – HFDN-23.0, Maxim Integrated Products, April 2003.
5. Reference Design Note: “Multi-Rate (100Mbps to 2.7Gbps) Small Form Factor Pluggable (SFP) Transceiver.” – HFRD-04, [Maxim Integrated Products](#), Available in Summer 2003.
6. Data Sheet: “1.3um MQW-FP Laser Diode Module: SLT2170-xN Series” – ExceLight / Sumitomo Electric, February 2001.