



APPLICATION NOTE 2100

## Derive 5V From Four AA Cells

Four AA cells in series—a common power source for portable instruments—produces a battery voltage that declines from about 6V when fresh to about 4V when discharged. For 5V regulators, this above-and-below variation complicates the circuit design.

Flyback-transformer circuits can convert 6V-to-4V inputs to a regulated 5V, as can a step-up (boost) converter followed by a linear regulator. (For  $\pm 5V$  requirements, you can choose either circuit plus a charge pump.) If, however, the instrument is fully portable and the battery voltage can float, a less complicated inverter circuit can easily generate the 5V or  $\pm 5V$  rails. Moreover, the inverter's single switching frequency simplifies filtering and precludes the generation of beat frequencies.

The inverter circuit substitutes a transformer with two matched windings for the usual inductor (**Figure 1a**). When IC1's internal switch turns off, the circuit impresses  $V_{OUT}$  plus a diode drop across each winding. With a proper choice of reference connection as shown, the second (right-hand) winding can generate an additional supply voltage (-5V in this case).

$V_{OUT}$  (pin 8) is the feedback connection. For stability, the regulated output (5V in this case) should have the heavier load. It usually does, because the negative rail in most systems is only a bias supply. But, if your system demands more load current from the -5V output, you should reconnect the second winding to produce the 5V output, as shown in **Figure 1b**.

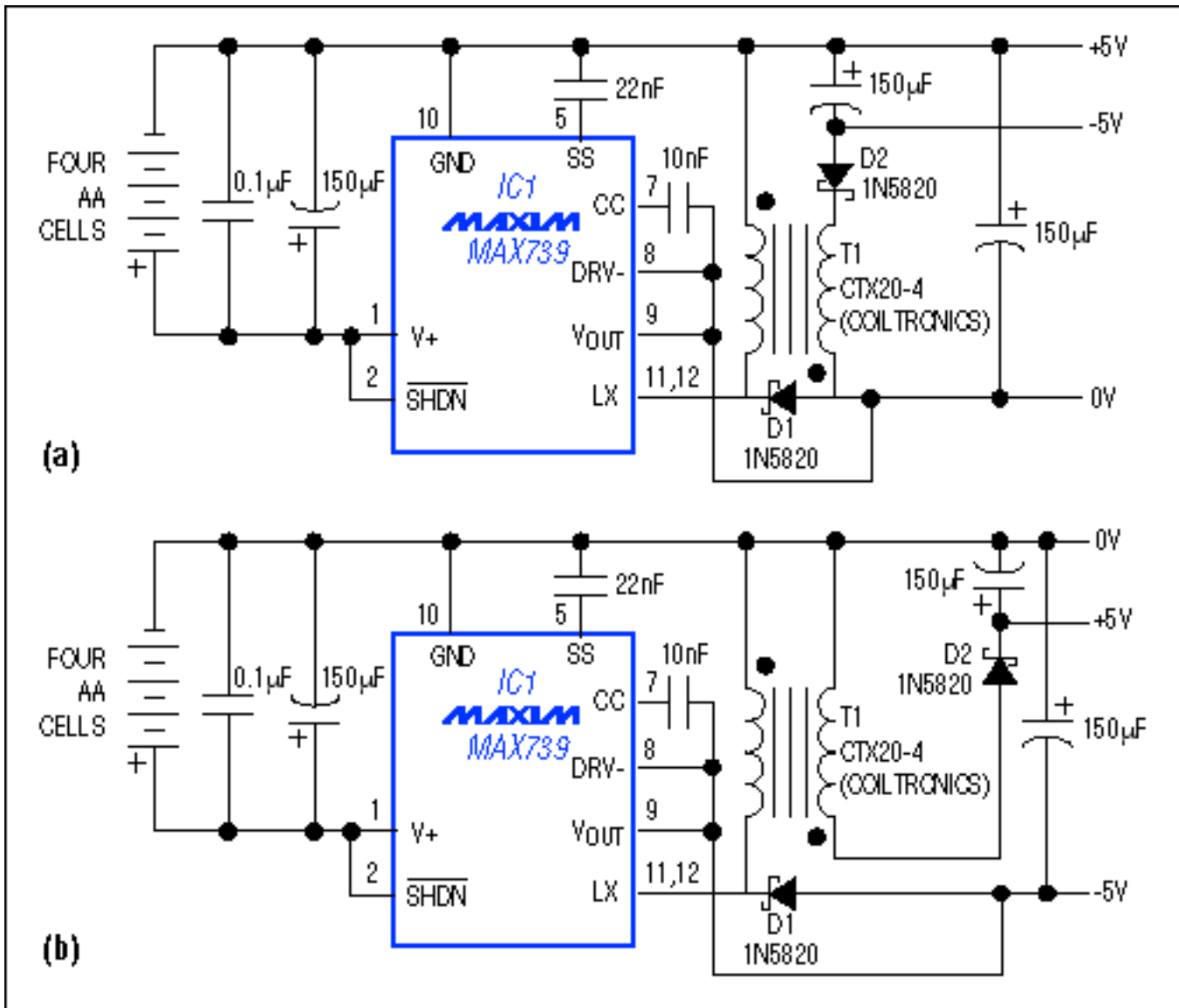

Figure 1. A 1:1 transformer enables this inverting switching regulator to generate -5V (a). Different connections for the right-hand coil are recommended if -5V supplies the heavier load current (b).

The transformer should have side-by-side bifilar windings for best coupling, but an off-the-shelf (non-bifilar) transformer such as the Coiltronics CTX20-4 gives acceptable performance (**Table 1**). The  $V_-$  value (nominally -5V) depends on the load currents and the transformer turns ratio (which may deviate from 1:1). Loads of 5mA to 50mA @  $V_-$  and 50mA @ 5V, for example, cause a  $V_-$  change of less than 300mV—less than that expected from a charge pump. When unloaded,  $V_-$  increases due to the rectification of ringing that occurs when D2 turns on.

**Table 1. V<sub>OUT</sub> (V+ and V-) vs. V<sub>IN</sub> and R<sub>LOAD</sub> for Figure 1b**

Input Voltage (V)	Input Current (mA)	V+ Load (Ω)	V+ (V)	V- Load (Ω)	V- (V)	Efficiency (%)
6	1.68	None	5.07	None	6.55	—
6	62	100	5.08	None	10	69.37
6	68	100	5.08	1000	5.68	71.16
6	124	100	5.08	100	5.41	74.02
5	1.8	None	5.08	None	6.48	—
5	74.5	100	5.08	None	10	69.28
5	82.5	100	5.08	1000	5.69	70.41
5	151	100	5.08	100	5.42	73.09
4	1.8	None	5.1	None	7	—
4	95	100	5.1	None	10	68.45
4	105	100	5.1	1000	5.71	69.69
4	196	100	5.1	100	5.3	68.31

Note: 1000Ω load gives 5mA at output.  
100Ω load gives 50mA at output.

---

Application Note 2100: <http://www.maxim-ic.com/an2100>

#### More Information

For technical questions and support: <http://www.maxim-ic.com/support>

For samples: <http://www.maxim-ic.com/samples>

Other questions and comments: <http://www.maxim-ic.com/contact>

#### Related Parts

MAX739: [QuickView](#) -- [Full \(PDF\) Data Sheet](#) -- [Free Samples](#)

AN2100, AN 2100, APP2100, Appnote2100, Appnote 2100

Copyright © by Maxim Integrated Products

Additional legal notices: <http://www.maxim-ic.com/legal>