



APPLICATION NOTE 210

Meet SFF-8472 Resolution and Accuracy Goals with Internal Calibration

Abstract: This application note shows how to provide precalibration, called internal calibration by the SFF-8472 standard, for monitoring optic signals. The calibration technique uses a laser driver, the MAX3996, and a temperature-controlled resistor and monitoring IC, the DS1858, to meet SFF-8472 resolution and accuracy goals.

Introduction

Some standards, such as the SFF-8472, require that fiber optic signals be monitored. Two means of calibration are available to the designer. Precalibration, referred to by the SFF-8472 Standard as internal calibration, calls for the conditioning of the analog signals to comply with a mandated scale. Postcalibration, referred to by the SFF-8472 Standard as external calibration, is a computational technique conditioning the digital output to comply with a mandated scale. Application note 174, "[Monitor calibration in fiber optic applications](#)" explains the two types of calibration. This application note is an example of how to provide precalibration when using the [DS1858](#) given a fixed design, and meet SFF-8472 resolution and accuracy goals. For designers who intend their module to serve in a wide range of applications, a more flexible solution with built-in internal calibration is better suited.

Scaling the DS1858

The SFF-8472 Standard specifies scaling for the five channels in the *Internal Calibration* section. In the DS1858, temperature and V_{CC} are factory calibrated to comply with the respective scales. For the remaining three channels, referred to in the standard as Tx Bias, Tx Power, and Rx Power, the three inputs on the DS1858 are MON1, MON2, and MON3. All three MON channels are identical. Therefore, the assignment is arbitrary. All three channels are factory calibrated to read FFFF at 2.5V. We will show how to condition the signals coming into MON1 and MON2 to provide a scale that is compliant with the SFF-8472.

Example Using the DS1858 and MAX3996

Figure 1 shows the use of a laser driver, the [MAX3996](#), along with the DS1858 in a design that satisfies internal calibration requirements of SFF-8472. Supply bypassing and pins were left out for simplicity.

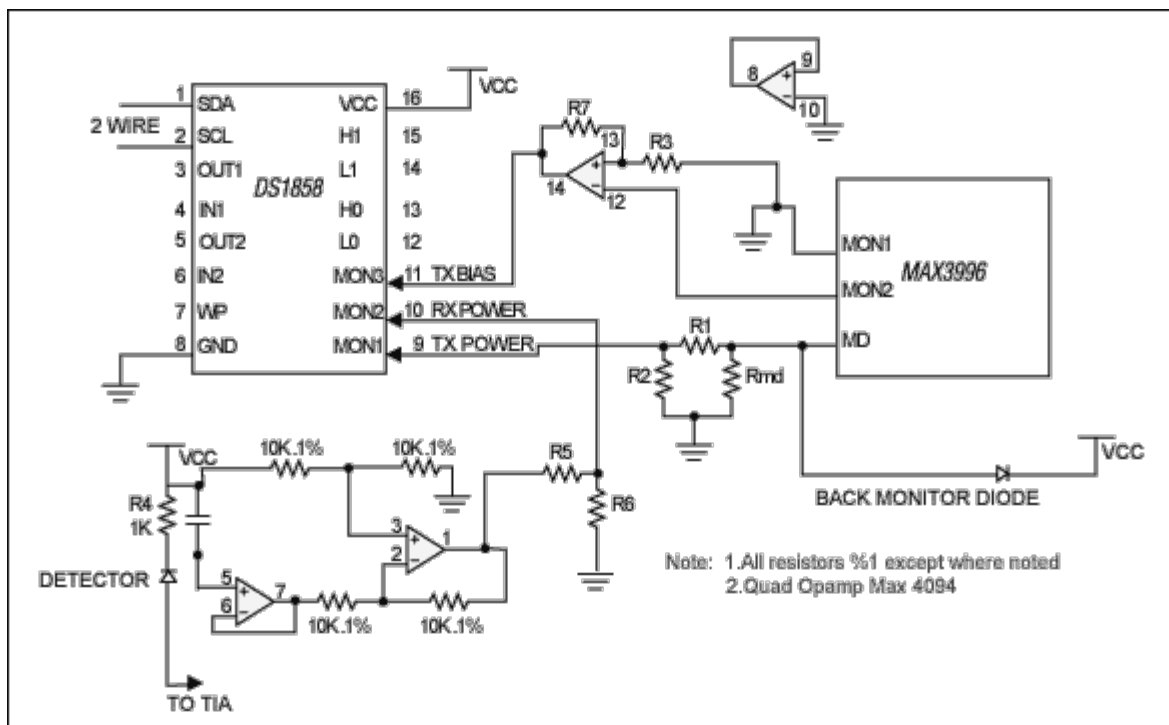

Figure 1.

Tx Power originates at MAX3996 pin MD as a voltage representative of the back monitor diode's current. This voltage is 1.12V ($\pm 8\%$) and is independent of Tx Power setting (back monitor diode current setting). R1 and R2 are chosen by design so that the voltage generated into the DS1858 complies with the Tx Power dBm scale. For example, 0dBm is expected to generate a digital output of 2710h, according to SFF-8472. The voltage at DS1858(9) that would generate 2710h is 0.381V (since 2.5V generates FFFFh). This sets the nominal values of R2 (62k Ω) and R1 (100k Ω). The standard requires a 3dB accuracy. The errors are less than 13.5% or about 0.5dB (8% for the voltage at MD, and 0.5% FS or 3.5% for the DS1858, and 2% for the resistors).

Rx Power is derived from average received power. The differential voltage is a measure of the detector current. It is converted to a single-ended voltage. For example, -10dBm is expected to generate a digital output of 3E8h, according to SFF-8472. The voltage at DS1858(10) that would generate 3E8h is 0.038V (since 2.5V generates FFFFh). If the average detector current into R4 is 100 μ A nominal then 100mV_{DC} will be sensed by the instrumentation amp. The divider network to convert 100mV into 38mV consists of R5 = 10k Ω and R6 = 6.2k Ω . The standard requires a 3dB accuracy. The errors, excluding photodetector conversion, are less than 36% or 2dB (0.5% FS or 33% for the DS1858, and 3% for resistors and amplifier offset/bias errors). It is noteworthy that, in order to avoid significant common-mode errors, the 10k Ω resistors have to be 0.1% with low temp co (50ppm/ $^{\circ}$ C or less). This leaves room in the error budget for 1dB (+25%, -21%) to cover photodetector variation. If this is not sufficient for the particular photodetector used then a pot should be substituted for R4.

Tx Bias originates within the MAX3996 (pin MON2) as a voltage proportional to bias current. For example, this voltage at 60mA is 0.66V ($\pm 15\%$). R3 and R7 are chosen by design so that the voltage generated into the DS1858 complies with the bias current scale. For example, 60mA of bias current is expected to generate a digital output of 7530h, according to SFF-8472. The voltage at DS1858(11) that would generate 7530h is 1.14 (since 2.5V generates FFFFh). This sets the nominal values of R3 (10k Ω) and R7 (7.15k Ω). However because the standard requires a better than 10% accuracy, a variable resistor or potentiometer is suggested for R3, such as the [DS1804](#).

Concluding Remarks

The preceding work shows that, for a given design, a discrete implementation of the internal calibration requirement is reasonably attainable within the allowable error budget of the SFF-8472 standard. Part-to-part variation was taken into account. By preprocessing the signal going into the DS1858 no loss of resolution occurs.

Other implementations using other laser drivers, will differ in detail only but will achieve similar results. Typically, two or three op amps and a small number of discrete components are adequate to achieve similar results.

Related Parts

[DS1858](#) Dual Temperature-Controlled Resistors with Three Monitors -- [Free Samples](#)

[MAX3996](#) +3.0V to +5.5V, 2.5Gbps VCSEL and Laser Driver -- [Free Samples](#)

Automatic Updates

Would you like to be automatically notified when new application notes are published in your areas of interest? [Sign up for EE-Mail™](#).

Application note 210: www.maxim-ic.com/an210

More information

For technical support: www.maxim-ic.com/support

For samples: www.maxim-ic.com/samples

Other questions and comments: www.maxim-ic.com/contact

AN210, AN 210, APP210, Appnote210, Appnote 210

Copyright © by Maxim Integrated Products

Additional legal notices: www.maxim-ic.com/legal