

APPLICATION NOTE 2025

# Relay Driver Requires Only 25% Power

The circuit of **Figure 1** implements the accepted practice of driving a solenoid initially with full power, then reducing to a "holding" power after the component has mechanically "pulled in."

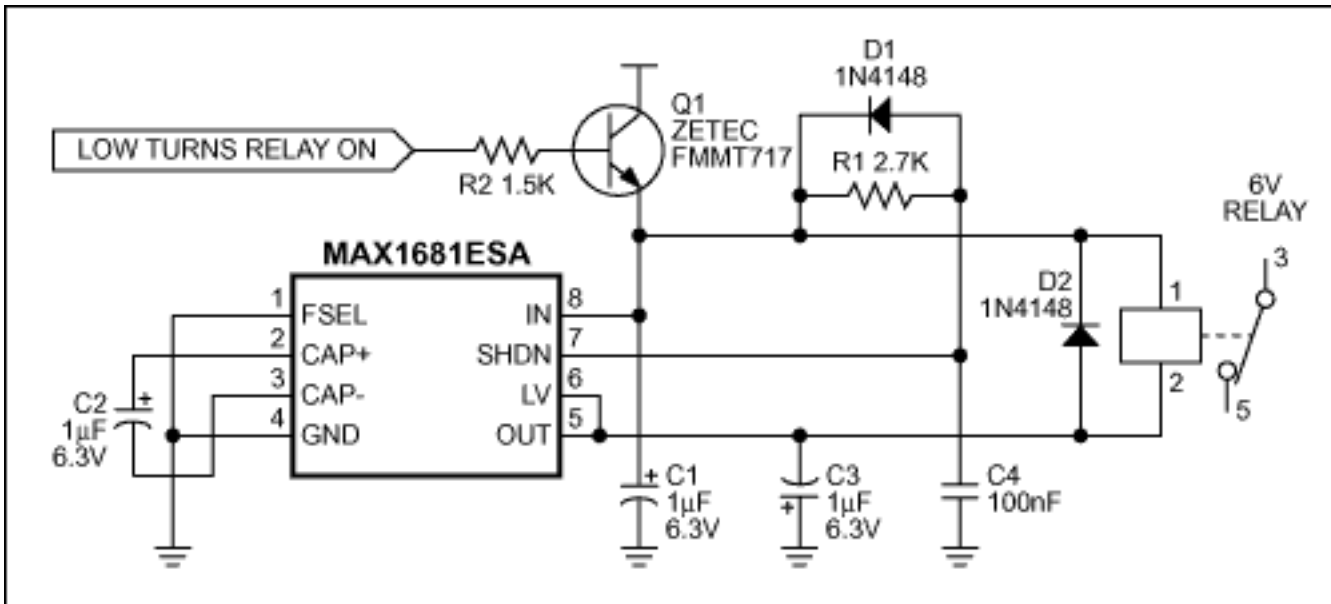

Figure 1. This circuit applies a voltage close to 6V to turn on the relay, then reduces the power consumption 75% by lowering the applied holding voltage to about 3.3V.

The circuit shown drives a 6V relay from 3.3V, and uses a charge pump (IC1, configured as a voltage inverter) to produce the additional -3V needed to activate (pull in) the relay. Turning on Q1 with an external control signal applies approximately 3.3V to the top of the relay, and IC1 (activated by the presence of 3.3V at pin 8) applies -3V to its lower terminal. Novel features in IC1 make the circuit very compact:

The charge pump's (IC1's) internal switching frequency is fast (1MHz) compared to the more familiar ICL7660, which switches at 10kHz. This high speed allows the use of small (1µF) values for the input, output, and "flying" capacitors (C1, C3, and C2). These components can be low-cost X7R ceramic capacitors such as the 1206YC105MAT2A from AVX.

When IC1 enters shutdown (logic high on pin 7), its output (pin 5) does not assume a high impedance, but instead connects to ground through an internal switch with less than 5Ω of on-resistance. This capability allows SHDN to act as a power switch, gating the inverter output from a nominal -3V (charge pump enabled) to ground (charge pump disabled). IC1 draws less than 1µA when disabled.

For the prototype circuit operating at 3.3V, IC1's operating frequency measured 955kHz. The table below shows the measured charge-pump performance, in terms of the total voltage across the relay, for 400Ω, 180Ω, and 90Ω 6V relays:

Relay, 6V	Pull-In Voltage with Tantalum-Bead Capacitors	Pull-In Voltage with Low-ESR C2	Holding Voltage
400Ω (90mW)	5.51V	6.18V	3.293V
180Ω (200mW)	4.80V	5.87V	3.283V
90Ω (400mW)	3.94V	5.40V	3.266V

For the first column of pull-in voltage, C1, C2, and C3 are ordinary, 1μF, leaded tantalum-bead capacitors rather than low-ESR types. For the second column, C2 alone is replaced with a low-ESR capacitor with maximum resistance of 350mΩ (a Sanyo OS-CON 25SC1M). This capacitor gives a substantial improvement in performance, illustrating the need for careful selection of components in charge-pump converters.

The high-side pnp transistor turns the relay on and off. The small SOT23 device shown (Zetex FMMT717) was selected for high  $h_{FE}$  (180 minimum) at its continuous- $I_C$  rating of 2.5A. High  $h_{FE}$  allows a high-valued base-limiting resistor. To save even the small base current, substitute a p-channel MOSFET for Q1.

---

Application Note 2025: [www.maxim-ic.com/an2025](http://www.maxim-ic.com/an2025)

### More Information

For technical questions and support: [www.maxim-ic.com/support](http://www.maxim-ic.com/support)

For samples: [www.maxim-ic.com/samples](http://www.maxim-ic.com/samples)

Other questions and comments: [www.maxim-ic.com/contact](http://www.maxim-ic.com/contact)

---

### Keep Me Informed

Preview new application notes in your areas of interest as soon as they are published. Subscribe to [EE-Mail - Application Notes](#) for weekly updates.

---

### Related Parts

MAX1681: [QuickView](#) -- [Full \(PDF\) Data Sheet](#) -- [Free Samples](#)

AN2025, AN 2025, APP2025, Appnote2025, Appnote 2025

Copyright © by Maxim Integrated Products

Additional legal notices: [www.maxim-ic.com/legal](http://www.maxim-ic.com/legal)