

APPLICATION NOTE 2019

## Buffer Amplifiers Solve VCO Problems

*Abstract: Poor isolation of an oscillator circuit's output can cause adverse effect. This article describes key application issues surrounding VCO circuits such as load pulling, supply pushing, phase noise and effects of radiated energy from nearby power amplifiers (PAs). It is shown how using a VCO buffer to isolate the oscillator mitigates these problems. The MAX2472/MAX2473 VCO buffers are introduced along with an application circuit and measurement data.*

Common design practice is to isolate two circuit stages by introducing a buffer amplifier between them. Isolation minimizes many adverse effects, and at radio frequencies (RF). Poor output isolation can disturb oscillator performance, so a buffer stage is often included at oscillator outputs.

Before discussing the addition of a buffer amplifier stage, we consider some typical VCO characteristics and how isolation problems can degrade performance. A common problem, for example, is the frequency change exhibited by a VCO in response to varying load conditions (frequency pulling). A change in impedance seen by the VCO output can induce changes in the dc voltages across junctions of the VCO's active device. A change in the collector-to-base voltage ( $V_{cb}$ ) of a bipolar device, for instance, affects the collector-to-base capacitance ( $C_{cb}$ ), which in turn can alter the oscillation frequency by affecting the overall tank resonance (**Figure 1**).

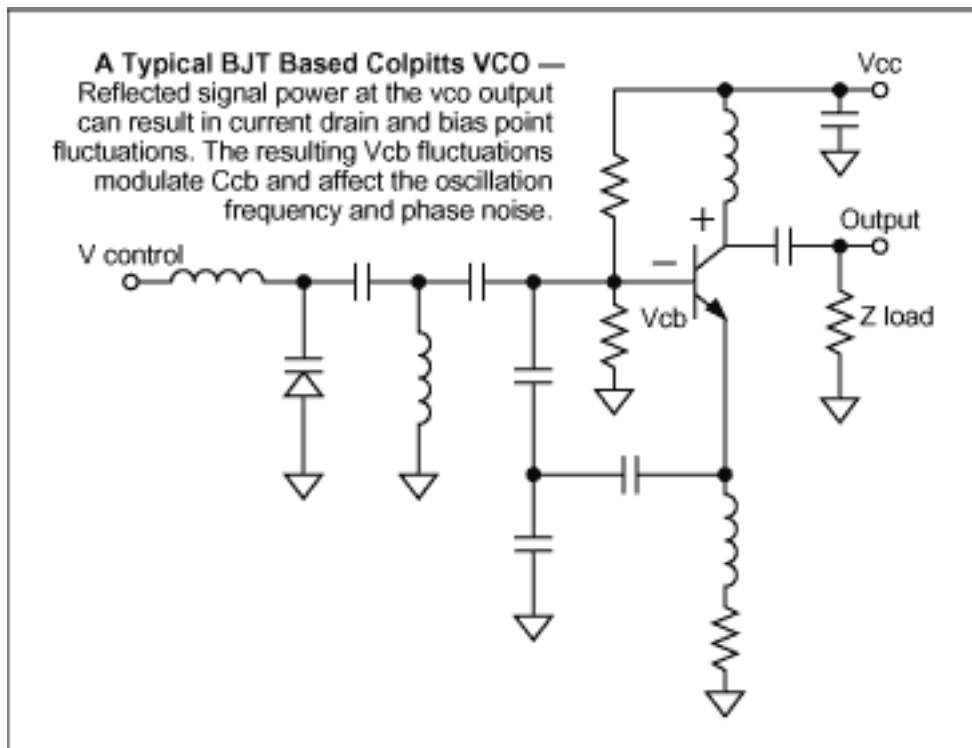

Figure 1. Signal power reflected at the output of this Colpitts VCO can produce fluctuations in the current drain and bias point. As a result,  $V_{cb}$  fluctuations in the transistor modulate  $C_{cb}$ , affecting the oscillator frequency and phase noise.

Another frequency-pulling phenomenon is sometimes referred to as injection locking or injection pulling. It concerns the effect of an interfering signal that is very near the VCO's operating frequency. When an interferer's amplitude at the VCO output port is sufficient, it can cause the VCO to shift its oscillation frequency to match the interfering frequency<sup>1</sup>.

Another key performance factor affected by poor output isolation is phase noise. Much research has been done in the last few years to better describe the generation of phase noise in oscillators. Conditions that produce phase noise include changes in load impedance, power reflections back to the VCO output, excessive ground current, and radiated coupling due to poor RF layout. The induced voltage changes can cause bias-current fluctuations in the active device, a modulating effect on Ccb, perturbations in amplitude, and other subtle problems that degrade performance<sup>2</sup>.

Adequate VCO isolation also depends on board layout, and whether the VCO is discrete, integrated, or modular. VCO operation can be disturbed by any radiated RF energy coupled to the VCO. The energy can be coupled directly to the VCO or via other circuits or traces connected to the VCO. Even unconnected circuit traces running near the VCO can serve as antennas that pick up radiated energy and re-radiate it to the VCO. Proper layout should always be observed when VCO noise performance is critical.

RF energy conducted through the signal path and back to the VCO output can also produce the problems discussed above. One cause of such conducted degradation can be the RF power amplifier (PA) turning on or off, which can cause an impedance change in the signal path or in other circuits, thereby picking up radiated RF energy and conducting it back through the signal path. Good pc layout helps to minimize radiated and conducted perturbations of the VCO. Grounding, shielding, and the routing of traces near the VCO can affect VCO operation, as well as the amount of isolation the VCO buffer circuit can achieve.

Now that some of the degrading mechanisms have been pointed out, it is also important to understand how they manifest themselves during radio operation. Poor output isolation can degrade the PLL lock time when a reflected signal reaches the VCO. It may be necessary to isolate the phase detector input from the receiver or transmitter to alleviate this problem. An increase in phase noise can also degrade the adjacent-channel protection in either transmit or receive mode. Modulation distortion during transmit operation can also be a result of poor VCO isolation.

Resolving a radiated-interference problem often requires considerable thought and experimentation, but you can usually resolve a conducted-interference problem by simply adding a VCO buffer amplifier. An integrated buffer such as the MAX2472 saves board real estate, and provides excellent isolation of the VCO. Its circuit topology is ideal for providing the LO and phase detector input signals while maintaining isolation between them and the VCO.

A quick analysis of the S-parameters in Table 1 will indicate features that make the MAX2472 an excellent solution to the problem of poor VCO output isolation<sup>3</sup> (**Figure 2**). The typical isolation achieved between VCO and mixer is about 44db at 900MHz and 30dB at 1900MHz. The device provides highly stable gains at those frequencies, of 10dB and 8dB respectively.

**Table 1. Typical MAX2472 S-parameters**

Frequency (MHz)	900	1900
S <sub>11</sub> (mag, phase)	0.68786, -21.6	0.529663, -44.1
S <sub>21</sub> (mag, phase)	1.764006, -80.4	1.592209, -117.6
S <sub>12</sub> (mag, phase)	0.005821, 137.5	0.031189, 173.4
S <sub>22</sub> (mag, phase)	0.810028, -29.4	0.776247, -61.6

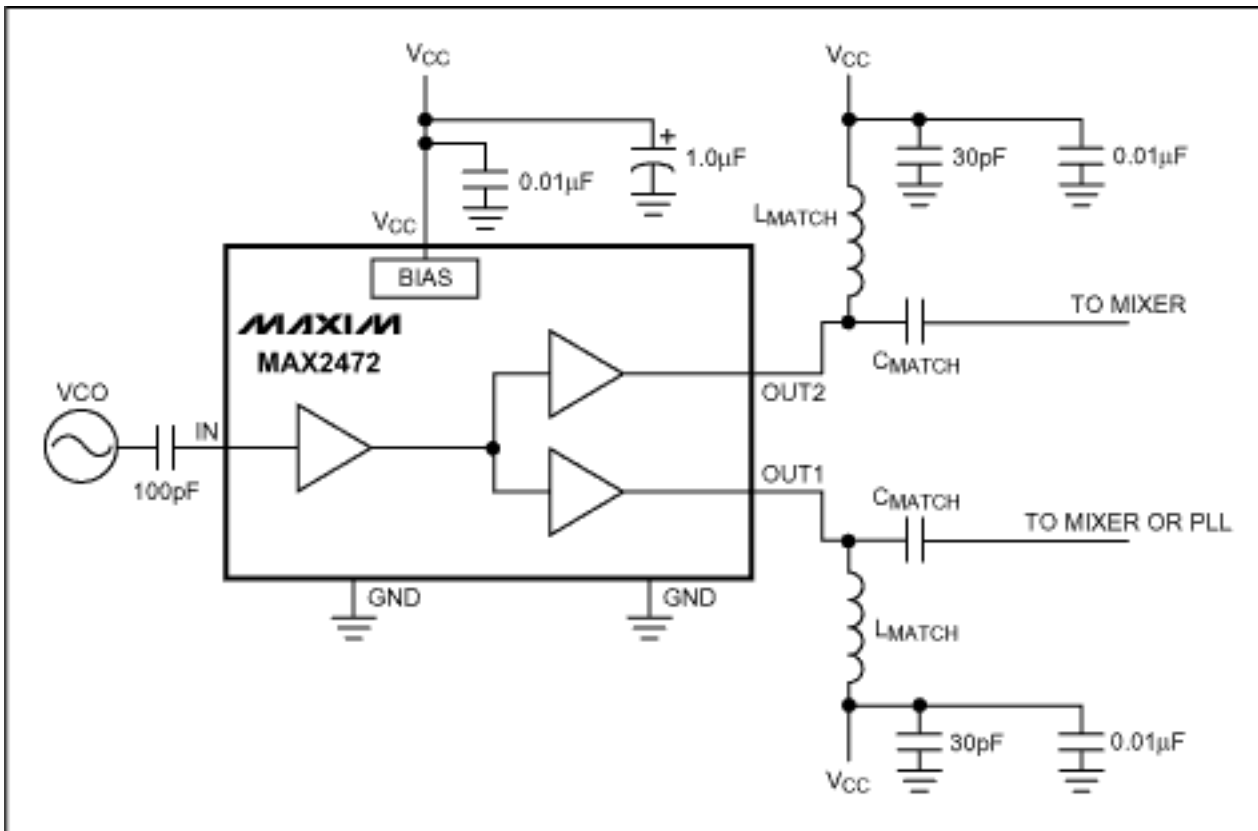

Figure 2. At 900MHz, this IC buffer amplifier (MAX2472) provides about 10dB of gain and 44dB of isolation between VCO and mixer.

The MAX2473 makes a good VCO buffer when there is only one signal path at the VCO output, and it provides even greater reverse isolation in the same small SOT23-6 package. As an added feature, its adjustable bias current minimizes current drain in cell phones and other battery-powered applications.

Various mechanisms can degrade VCO performance in a portable-radio environment, but solutions to those problems are available. Some problems require extensive analysis and elaborate solutions, and others are easily overcome. Small, integrated VCO buffers like the MAX2472/MAX2473 can provide the simple solutions for VCO problems.

## Notes

1. B. Razavi, *RF Microelectronics*, Prentice Hall 1998, pp225-226.
2. T.H. Lee and A. Hajimiri, *Oscillator Phase Noise: A Tutorial*, IEEE Journal of Solid-State Circuits, vol. 35, Mar. 2000.
3. [MAX2472/MAX2473](#) data sheet, Maxim Integrated Products.

A similar version of this article appeared in the November 2002 issue of *Microwave & RF* magazine.

Application Note 2019: [www.maxim-ic.com/an2019](http://www.maxim-ic.com/an2019)

## More Information

For technical questions and support: [www.maxim-ic.com/support](http://www.maxim-ic.com/support)

For samples: [www.maxim-ic.com/samples](http://www.maxim-ic.com/samples)

Other questions and comments: [www.maxim-ic.com/contact](http://www.maxim-ic.com/contact)

**Keep Me Informed**

Preview new application notes in your areas of interest as soon as they are published. Subscribe to [EE-Mail - Application Notes](#) for weekly updates.

---

### **Related Parts**

MAX2472: [QuickView](#) -- [Full \(PDF\) Data Sheet](#) -- [Free Samples](#)

MAX2473: [QuickView](#) -- [Full \(PDF\) Data Sheet](#) -- [Free Samples](#)

AN2019, AN 2019, APP2019, Appnote2019, Appnote 2019

Copyright © by Maxim Integrated Products

Additional legal notices: [www.maxim-ic.com/legal](http://www.maxim-ic.com/legal)