



APPLICATION NOTE 2015

## Overcurrent/Overdischarge Protection for Lead-Acid Batteries

*Abstract: This application note describes the use of a current-sense amplifier with internal dual comparators to monitor and protect against too low battery voltage and too high battery current. While written for lead-acid batteries, the circuit and concept can be extended to NiCd, Li-ion and other battery chemistries. An external power P-channel MOSFET is in series with the battery and its load. It works as a normally closed switch which can be opened if the current-sense amplifier and comparators detect either a high load current OR a low battery voltage. The high current comparator can be latched to detect brief over currents and reset by an external push button.*

The circuit of **Figure 1** protects a lead-acid battery by disconnecting its load in the presence of excessive current (more than 5A), or a low terminal voltage indicating excessive discharge (< 10.5V). The battery and load are connected by a 0.025Ω current-sense resistor (R1) and p-channel power MOSFET (T1). T1 can handle 20V of drain-source voltage and continuous currents greater than 5A.

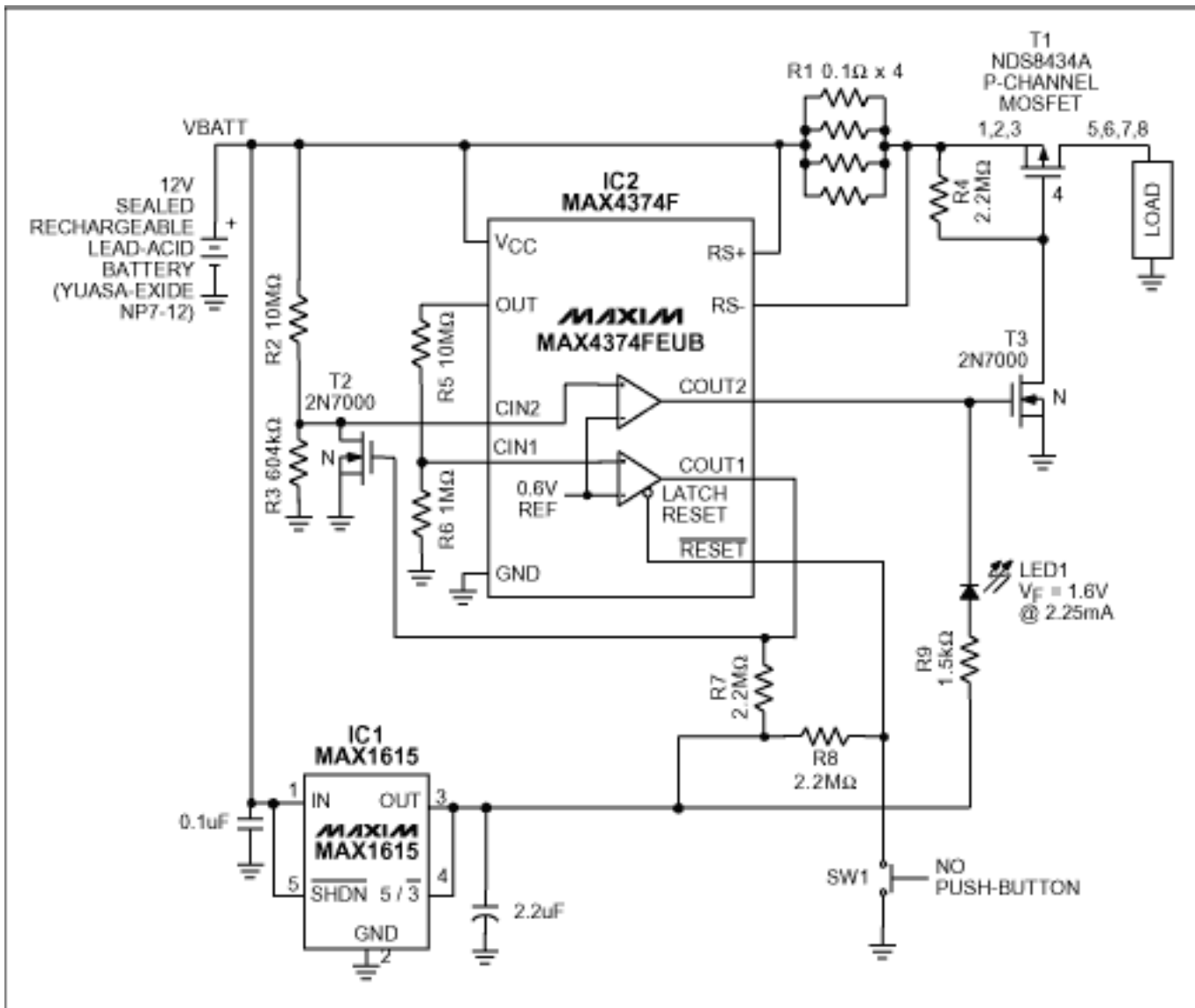

Figure 1. A fault condition (battery terminal voltage < 10.5V or battery current > 5A) causes T1 to open and LED1 to illuminate.

IC2 is a micropower device drawing only 50μA of supply current. It contains a dual comparator and a high-side current-sense amplifier whose output current is proportional to the current through R1. The top comparator (C2) senses battery voltage via R2/R3, and drives COUT2 low when the voltage falls below 10.5V. That action turns on LED1, turns off T3, and allows R4 to turn off T1 by pulling its gate high. Thus, the battery load is removed when battery voltage is less than 10.5V. Recharging the battery turns T1 back on automatically. C2's internal 1.5% hysteresis prevents output oscillation near the switching threshold.

A high-voltage micropower linear regulator (IC1) provides a stable 5V for pullup resistors R7 and R8. It also sources the 2.25mA required for fault indicator LED1. IC1 accepts input voltages as high as 28V, and draws a maximum quiescent supply current of only 8μA.

The output of latched comparator C1 is normally low, which turns off T2 and allows normal operation. When a load current above 5A drives the CIN1 voltage above 0.6V, the open-drain output COUT1 is latched high (open), allowing R7 to pull T2's gate high. The resulting low on CIN2 drives COUT2 low, disconnecting the load and illuminating LED1 just as an overdischarge does, except the load remains disconnected until IC2's active-low RESET input (normally pulled high via R8) is pulled to ground via the normally-open pushbutton switch SW1.

For technical questions and support: [www.maxim-ic.com/support](http://www.maxim-ic.com/support)

For samples: [www.maxim-ic.com/samples](http://www.maxim-ic.com/samples)

Other questions and comments: [www.maxim-ic.com/contact](http://www.maxim-ic.com/contact)

---

### **Keep Me Informed**

Preview new application notes in your areas of interest as soon as they are published. Subscribe to [EE-Mail - Application Notes](#) for weekly updates.

---

### **Related Parts**

MAX1615: [QuickView](#) -- [Full \(PDF\) Data Sheet](#) -- [Free Samples](#)

MAX4374: [QuickView](#) -- [Full \(PDF\) Data Sheet](#) -- [Free Samples](#)

AN2015, AN 2015, APP2015, Appnote2015, Appnote 2015

Copyright © by Maxim Integrated Products

Additional legal notices: [www.maxim-ic.com/legal](http://www.maxim-ic.com/legal)