

APPLICATION NOTE 1955

## Fast Start-Up Oscillator (FOX) Boosts Superhet Performance

*Abstract: Maxim has incorporated a unique fast-start oscillator system in the single chip superheterodyne RF receiver devices. Targeted for applications in the 300MHz–450MHz ISM (US) band, the receivers conserve battery power by reducing start-up time of the receiver. The fast-start oscillator circuit enables lower duty cycles for receiver scanning.*

A common application for simple RF data transmission is the remote keyless entry (RKE) system used in many new vehicles to lock and unlock vehicle doors, open the trunk, and control the security alarm. Future vehicles will use a RKE to locate vehicles and provide remote starting.

The operation of an RKE system is straightforward. It consists of a key-fob transmitter (usually one per user) and a vehicle-based receiver. The frequency of operation is usually 300MHz to 450MHz, but some of the new systems in Europe are considering a frequency allocation of 868MHz in the ISM band. Communications are simplex, meaning that data flows only from transmitter to receiver. Of the many reasons that justify this architecture, the most cited are low cost and extended battery life for the key fob.

To initiate action, the user depresses a button on the key fob, thereby waking an internal microcontroller that immediately outputs a data stream into the RF transmitter. The data stream includes a data preamble, the actual command (lock door, for instance), a rolling code for vehicle-to-vehicle security to ensure that your key fob does not unlock another vehicle, and (perhaps) a few checkb (**Figure 1**).

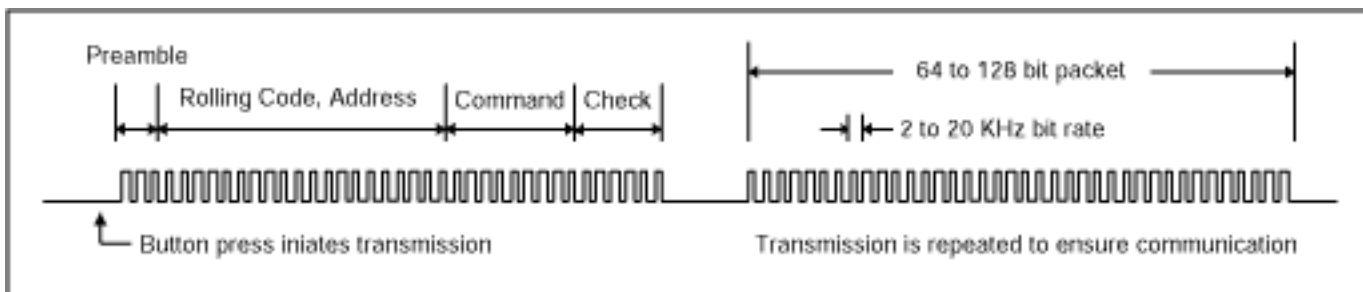

Figure 1. Pressing a button on the key fob of a remote keyless entry (RKE) system initiates transmission of a short data stream.

Complete data packets (64b to 128b) are usually transmitted at a rate between 2.4kHz and 20kHz, with RF modulation in the form of amplitude shift keying (ASK) or on-off keying (OOK, which is ASK in which the modulation is 0% or 100%). These modulation schemes minimize cost and extend battery life for the key fob.

As you may suspect, low price and long battery life are very important. The need for low price is obvious when you consider the number of systems in use (tens of millions). Maximum battery life is important for both transmitter and receiver.

For the key-fob transmitter, long battery life minimizes battery replacement by the user. The ideal transmitter battery would last the life of the vehicle, and such a battery is possible today, but you probably wouldn't want to carry the resulting large key fob in your pocket or purse. A small key fob is more convenient, but not if you must change batteries every two months. Most of today's products fall in the middle, offering a reasonable key fob size with battery life in the 2-to-5-year range.

Equally important is battery life for the receiver. The receiver battery must always be on, because a user can issue commands at any time. The RKE receiver is powered by the vehicle's battery (the same one used to start the vehicle). If power consumption in the receiver is too high, the battery won't have enough power to start the vehicle!

It may seem silly to worry about that possibility. The vehicle battery is huge, and a typical receiver draws only 1mA to 5mA. Such a small current drain is not a concern for vehicles in daily use, but the situation changes if you leave your vehicle at the airport for a couple of weeks or more.

Vehicle manufacturers therefore size their batteries accordingly. For an RKE system, battery size (capacity) is directly proportional to the product of power consumed by the receiver times the number of days it is powered. So, be forewarned if your vehicle is stored for longer than about 30 days. Back to the title of this article—how does the fast start-up of an oscillator in the superheterodyne receiver affect battery life?

To simplify calculations we use some mid-range values. Recalling the discussion of data packets and transmission speeds, assume a 100-bit data packet and 10kHz data rate (0.1ms per data bit). The 100-bit packet is therefore transmitted in 10ms. To save power in the receiver, we "time-slice" its operation by leaving it on only briefly—just long enough to determine if there is a valid transmission. This "on time" value usually produces a duty cycle of approximately 10%.

Because the receiver is time sliced, we need to provide additional transmissions to make sure that the receiver detects one of the requested actions. Normally, the key-fob transmission is repeated three more times, for a total of four transmissions. Total transmission time for the key fob is four times 10ms, or 40ms. For the receiver to act, it must completely decode at least one of the 100-bit (10ms) transmissions.

To catch at least one full transmission, we must poll the receiver to determine if valid data is present. (The receiver could be left on, but that costs power.) A given 40ms transmit packet may not be repeated, so one must poll the receiver often enough to catch at least one complete 10ms transmission. That requirement imposes a maximum time between receiver polls of 30ms.

But that interval may be too infrequent, allowing a command to be missed. The system timing may be a bit off, or there may be interference or other noise that corrupts the data. To be conservative, the system should be set up to catch at least two complete transmissions. Hence, we set the receiver time-slice circuit to 20ms. Every 20ms the receiver wakes up and attempts to decode the transmission. If valid data is present the receiver decodes it; otherwise it goes back to sleep for another 20ms.

To detect valid data, the receiver needs 7b–8b of data or 0.75ms of time to decode the information. That condition determines whether the transmitter is sending data at a frequency and format in which we are interested. Thus, the receiver needs to wake up for 0.75ms or so every 20ms. Unfortunately, only a perfect receiver can accomplish that feat.

The receiver needs time to wake up. Most amplifiers in the receiver can wake up and stabilize in a short time, but not the oscillator. Its piezoelectric crystal is an electromechanical element that needs time to begin oscillating, and a bit more time to stabilize at the desired frequency.

Note that some receiver specifications are vague in this regard. The important specification is the time interval between turning on the receiver and bringing the oscillator frequency within range (stabilization). Other specifications such as valid IF output are misleading. The IF output is valid when the oscillator begins operating. The receiver, though, may not be frequency-locked to the transmitter. That situation is like a radio tuned to 90MHz that is actually receiving 92MHz. Sure, the radio is working, but it is not receiving what you want.

Normal superheterodyne receivers can start and stabilize within 2ms to 5ms. We assume 2.25ms for our discussion. Adding 0.75ms for the data decode, they need a 3ms "on time" every 20ms to detect the key-fob transmission (**Figure 2**). The MAX1470 superheterodyne receiver, on the other hand, includes a fast-startup oscillator that minimizes turn-on time by maintaining vibration in the crystal, thereby reducing turn-on times from the normal 2.25ms to a fast 0.25ms. Adding the 0.25ms turn-on time to the 0.75ms data decode time, we need only 1ms every 20ms to detect a key-fob transmission. Thus, the MAX1470 saves power by performing the same measurement function in one third the time.

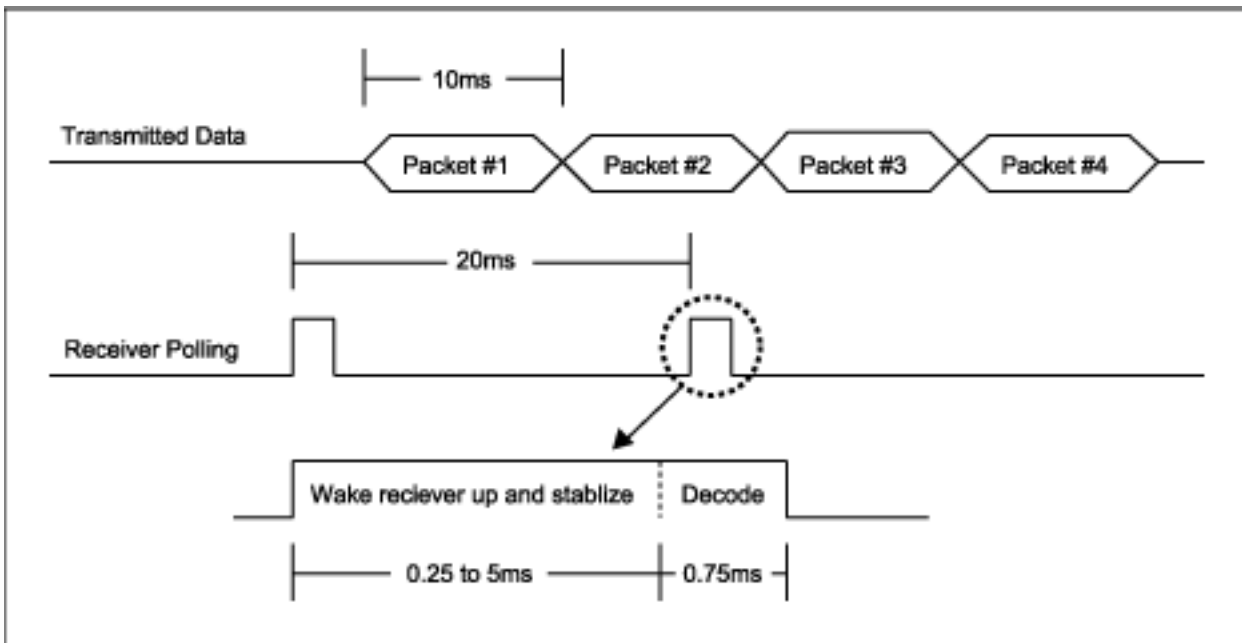

Figure 2. To monitor key fob transmissions, the RKE receiver must allocate time to wake up, stabilize, and then decode the incoming signal.

Most high-performance superheterodyne receivers (those with good sensitivity) draw 5mA at 5V when operating. MAX1470 receivers offer their best receiver sensitivity while drawing 5ma from a supply voltage of only 3.3V. Power saved at the lower supply voltage is substantial: normal superheterodyne receivers require 25mW; the MAX1470 requires 16.5mW. Adding the time function for each 20ms poll cycle (**Figure 3**) produces an energy requirement of  $25\text{mW} \times 3\text{ms} = 75\mu\text{J}$  for the normal superheterodyne receiver vs.  $16.5\text{mW} \times 1\text{ms} = 16.5\mu\text{J}$  for the MAX1470. The energy savings gained with a fast-wakeup receiver can therefore extend battery life by a factor of four or five.

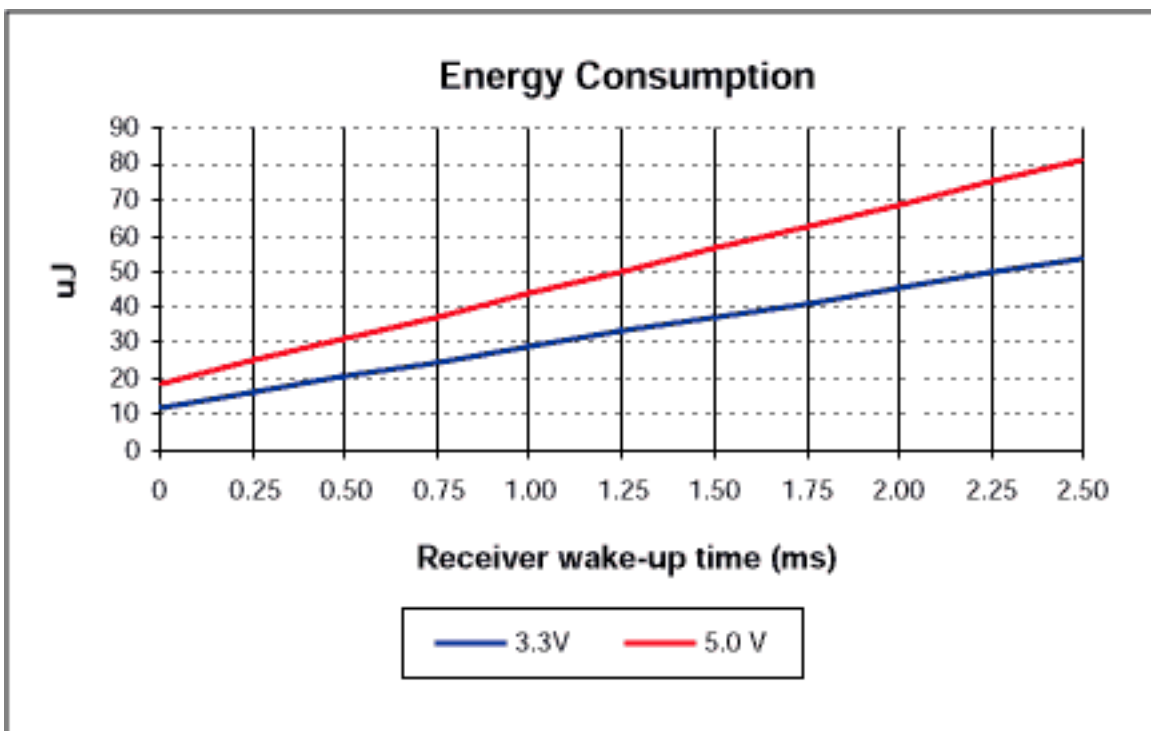

Figure 3. A shorter wakeup time saves energy, as does lowering the supply voltage.

Thus, for a given battery-life specification we can reduce the battery size and save money, or we can sample more often with the same power and reduce the size of the transmitter battery. Because vehicle batteries are sized mainly for "cranking amps" and reserve capacity, reducing their size may not allow a significant price advantage. On the other hand, reducing the size of the transmitter battery provides benefits, especially when applied in the new tire pressure monitoring (TPM) systems.

A TPM transmitter is essentially a key fob placed in a tire, usually in the valve stem. It measures the tire pressure and temperature and transmits a data packet, just as an RKE key fob does. But the information is transmitted often (rather than in response to a keypress action), because you want to detect inflation problems immediately. To detect slow leaks, the system also monitors each tire while the vehicle is resting.

Note that you cannot place a large battery on a valve stem without throwing off the wheel balance. Nor is the receiver battery easily replaced, so it should last considerably longer than a key fob battery. Low-power transmission is therefore essential for TPM. Though designers of RKE transmitters are naturally concerned with low-power operation, the system engineer knows that receiver improvements can also affect power consumption. For that purpose, he can do worse than equip the superheterodyne RKE receiver with a fast-startup oscillator.

A similar version of this article appeared in the October 21, 2002 issue of *Planet Analog* magazine.

---

Application Note 1955: [www.maxim-ic.com/an1955](http://www.maxim-ic.com/an1955)

### More Information

For technical questions and support: [www.maxim-ic.com/support](http://www.maxim-ic.com/support)

For samples: [www.maxim-ic.com/samples](http://www.maxim-ic.com/samples)

Other questions and comments: [www.maxim-ic.com/contact](http://www.maxim-ic.com/contact)

---

### Keep Me Informed

Preview new application notes in your areas of interest as soon as they are published. Subscribe to [EE-Mail - Application Notes](#) for weekly updates.

---

### Related Parts

MAX1470: [QuickView](#) -- [Full \(PDF\) Data Sheet](#)

MAX1471: [QuickView](#) -- [Full \(PDF\) Data Sheet](#)

MAX1472: [QuickView](#) -- [Full \(PDF\) Data Sheet](#) -- [Free Samples](#)

MAX1479: [QuickView](#) -- [Full \(PDF\) Data Sheet](#) -- [Free Samples](#)

AN1955, AN 1955, APP1955, Appnote1955, Appnote 1955

Copyright © by Maxim Integrated Products

Additional legal notices: [www.maxim-ic.com/legal](http://www.maxim-ic.com/legal)