

APPLICATION NOTE 1954

Designing Output-Matching Networks for the MAX1472 ASK Transmitter

The MAX1472 is a crystal-referenced phase-locked loop transmitter designed to transmit OOK/ASK data in the 300MHz to 450MHz frequency range. It supports data rates up to 100kbps. When matched to a 50Ω system, the MAX1472 PA is capable of delivering more than +10dBm of output power while maintaining an effective efficiency greater than 43%. The crystal-based architecture of the MAX1472 eliminates many of the common problems with saw transmitters by providing greater modulation depth, faster frequency settling, higher tolerance of the transmit frequency, and reduced temperature dependence.

The power amplifier (PA) of the MAX1472 is a high-efficiency open-drain class-C amplifier. With a proper output matching network, the PA can drive a wide range of impedances, including the small loop PC board trace antenna and any 50Ω antenna. **Figure 1** shows a recommended matching network for a 50Ω system. The matching network transforms the 50Ω load to a higher impedance at the output of the PA in addition to forming a bandpass filter that provides attenuation for the higher order harmonics.

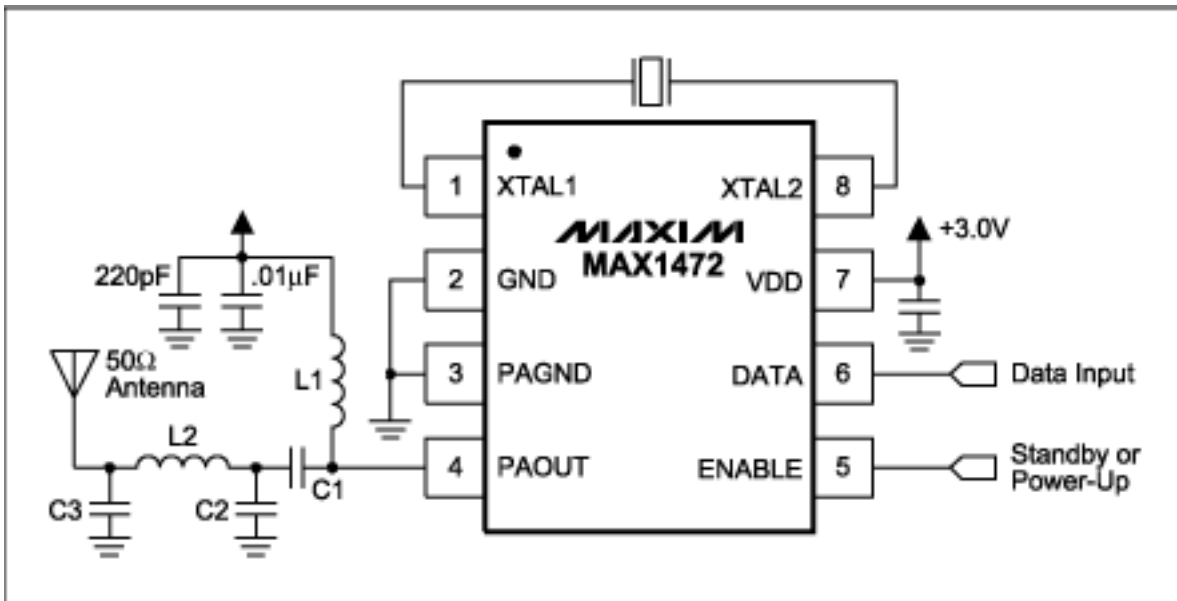

Figure 1. MAX1472 application circuit.

Table 1 shows the recommended output matching network component values for four widely used operating frequencies. These values were used with the MAX1472 evaluation kit (EV-kit). Some fine tunings may be required due to parasitic inductance and capacitance on PCB.

Table 1. Output Matching Network Component Values

-	$f_{RF} = 315\text{MHz}$	$f_{RF} = 345\text{MHz}$	$f_{RF} = 385\text{MHz}$	$f_{RF} = 433.92\text{MHz}$
C1	15pF	10pF	10pF	7pF
C2	22pF	18pF	15pF	12pF
C3	15pF	15pF	12pF	10pF
L1	27nH	27nH	24nH	22nH
L2	22nH	18nH	18nH	15nH
f_{XTAL}	9.84375MHz	10.78125MHz	12.03125MHz	13.56000MHz

Figures 2, 3, and 4 illustrate the output power and effective efficiency of the MAX1472 when configured with the above matching networks.

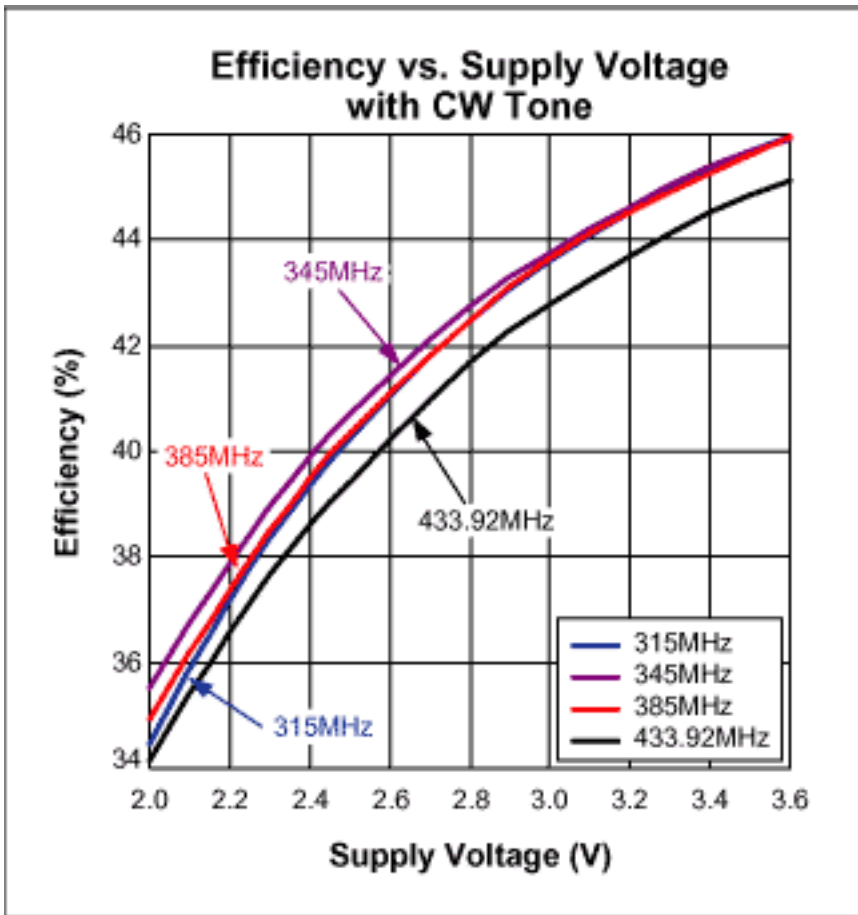

Figure 2. Efficiency vs. supply voltage with CW tone.

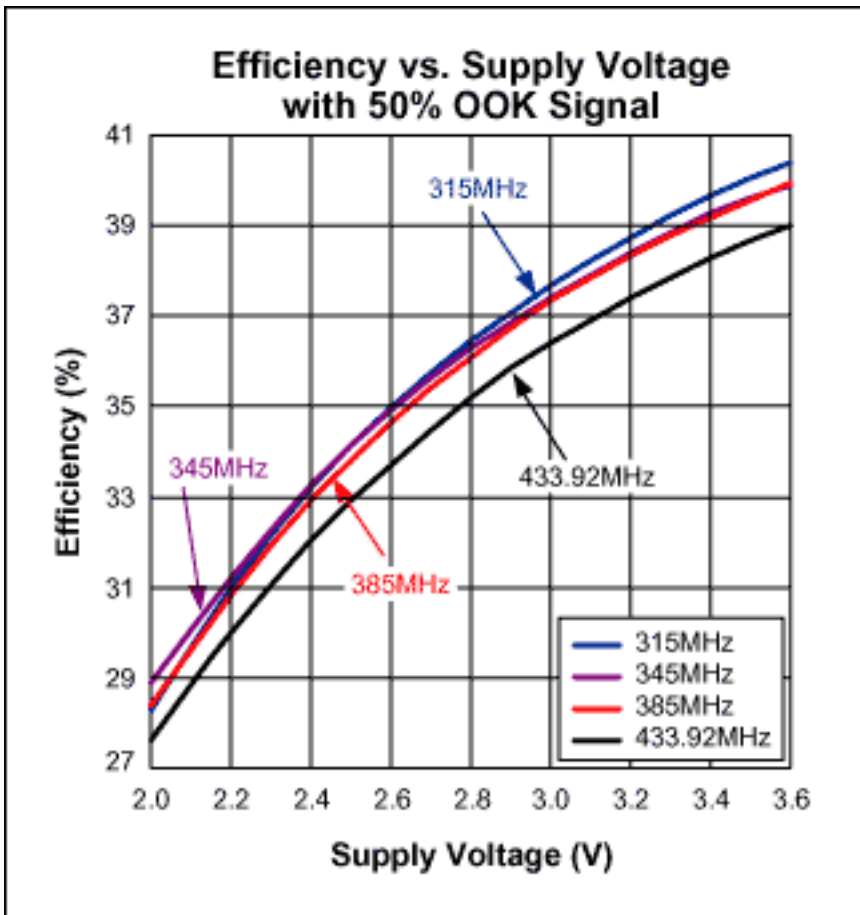

Figure 3. Efficiency vs. supply voltage with 50% OOK signal.

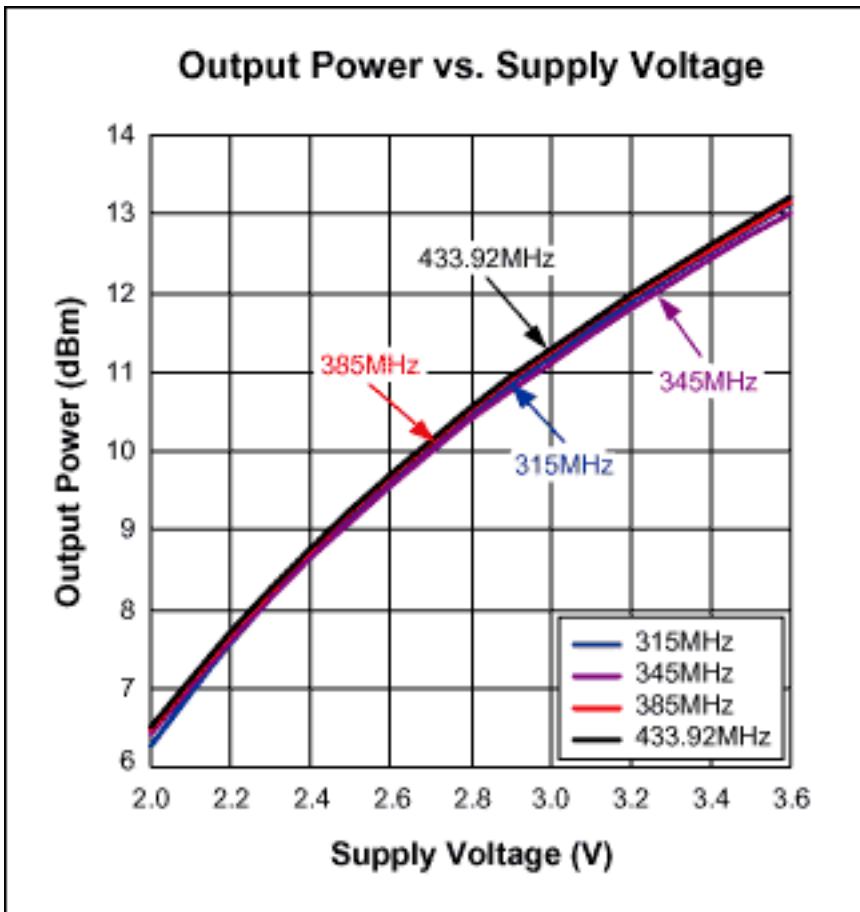

Figure 4. Output power vs. supply voltage.

Application Note 1954: <http://www.maxim-ic.com/an1954>

More Information

For technical questions and support: <http://www.maxim-ic.com/support>

For samples: <http://www.maxim-ic.com/samples>

Other questions and comments: <http://www.maxim-ic.com/contact>

Related Parts

MAX1472: [QuickView](#) -- [Full \(PDF\) Data Sheet](#) -- [Free Samples](#)

AN1954, AN 1954, APP1954, Appnote1954, Appnote 1954

Copyright © by Maxim Integrated Products

Additional legal notices: <http://www.maxim-ic.com/legal>