

APPLICATION NOTE 1951

# Class D Motor-Speed Control

*Abstract: Class D audio amplifiers provide a dual benefit for battery-powered portable devices. They enhance battery life, and they produce much less power dissipation than do their linear cousins. Those features make the class D amplifier an ideal candidate for controlling speed and direction in small electric motors.*

Class D audio amplifiers provide a dual benefit for battery-powered portable devices. They enhance battery life, and they produce much less power dissipation than do their linear cousins. Those features make the class D amplifier an ideal candidate for controlling speed and direction in small electric motors.

As shown in **Figure 1**, the standard application circuit for a class D audio amplifier (U1) requires only slight modifications. In place of the usual audio-signal input is a variable DC voltage generated by a potentiometer (R2). Resistor R1 biases the potentiometer to match the input range of U1. Full counter-clockwise rotation of the pot corresponds to maximum-speed reverse rotation of the motor. Mid-scale on the pot corresponds to motor off, and full clockwise rotation of the pot produces maximum-speed forward rotation in the motor.

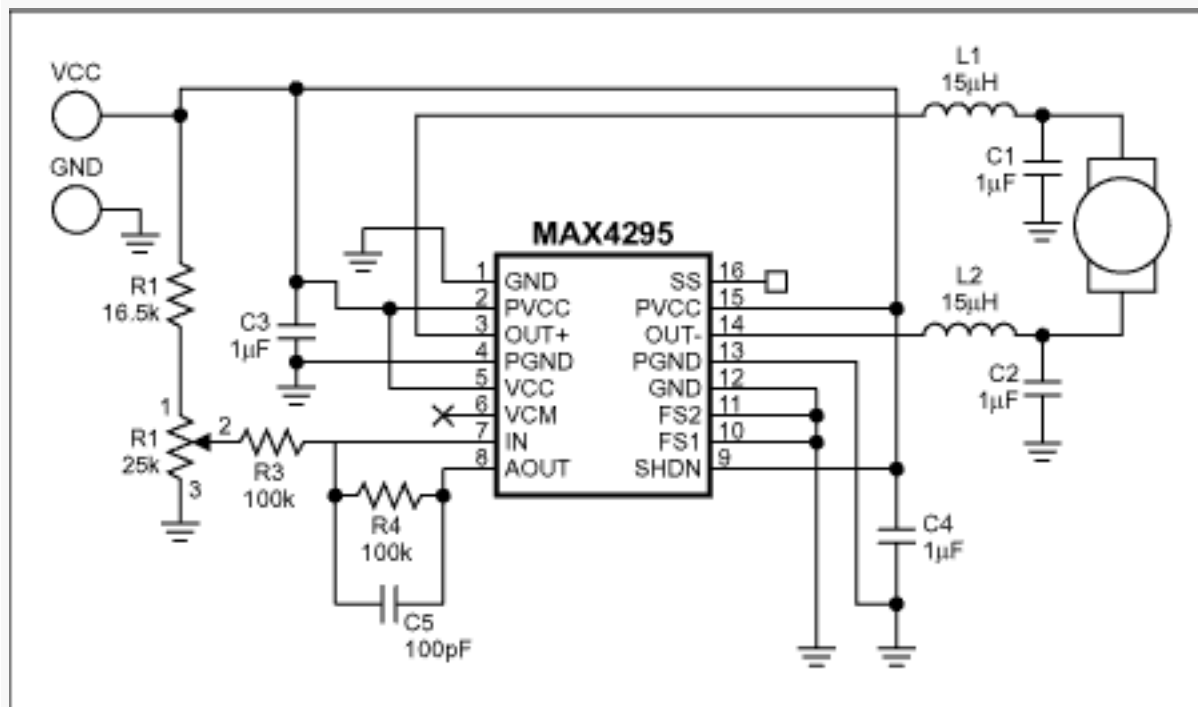

Figure 1. A class D audio amplifier (U1) helps implement this simple motor-speed controller.

The characteristics of a given motor may allow you to eliminate the amplifier's output filter (L1, L2, C1, and C2). But, unless the control circuitry shown is located near the motor, you should include the filter to reduce EMI.

A similar version of this article appeared in the May 1, 2003 issue of *EDN* magazine.

Application note 1951: [www.maxim-ic.com/an1951](http://www.maxim-ic.com/an1951)

**More Information**

For technical support: [www.maxim-ic.com/support](http://www.maxim-ic.com/support)

For samples: [www.maxim-ic.com/samples](http://www.maxim-ic.com/samples)

Other questions and comments: [www.maxim-ic.com/contact](http://www.maxim-ic.com/contact)

---

### **Automatic Updates**

Would you like to be automatically notified when new application notes are published in your areas of interest?

[Sign up for EE-Mail™](#).

---

### **Related Parts**

MAX4295: [QuickView](#) -- [Full \(PDF\) Data Sheet](#) -- [Free Samples](#)

AN1951, AN 1951, APP1951, Appnote1951, Appnote 1951

Copyright © by Maxim Integrated Products

Additional legal notices: [www.maxim-ic.com/legal](http://www.maxim-ic.com/legal)