



APPLICATION NOTE 1946

A MAX4454-based IQ Generator Tests RF Quadrature Modulators

Abstract: This app note describes a simple, low-cost, sine-cosine generator that can be used for testing quadrature modulators. Design and performance information is provided, as well as a method to customize the generator for the reader's specific needs.

Additional Information:

- [Wireless Product Line Page](#)
- [Quick View Data Sheet for the MAX4454](#)
- [Applications Technical Support](#)

Introduction

When evaluating quadrature modulators, it is useful to apply two sinusoids in quadrature at the baseband input to verify modulator accuracy. Parameters such as carrier suppression, side-band suppression, gain control range, and gain flatness over a band can all be quantified using the quadrature tones and examining the RF output spectrum. Also, a complete transmitter can be efficiently debugged without the need for complex-modulation lab generators. Once the system has been debugged and verified to operate, it can be further evaluated with higher-end equipment and tests.

To test a system with in-phase and quadrature (I/Q) inputs requires two tones at exactly 90° phase offset, or a 'sine-cosine' arrangement. While some moderate success may be obtained by linking two lab generators (by external references etc.), the task can prove frustrating and in some cases impossible.

Presented in **Figure 1** is a practical approach to generating a sine-cosine pair. This method takes a Resistor-Capacitor (RC) bridge and drives it with a single sine-wave. The resulting two signals (sine and cosine) are then fed to separate unity gain operational amplifiers (a single MAX4454) for buffering, and are accessible through 50Ω ports. The original sine-wave can be generated by one inexpensive function generator, and the entire solution can be built from scratch in an afternoon with commonly available components. The MAX4454 has excellent characteristics for this: 200MHz GBW (gain bandwidth), low noise, ultra-low IMD (intermodulation distortion) and is unity-gain stable.

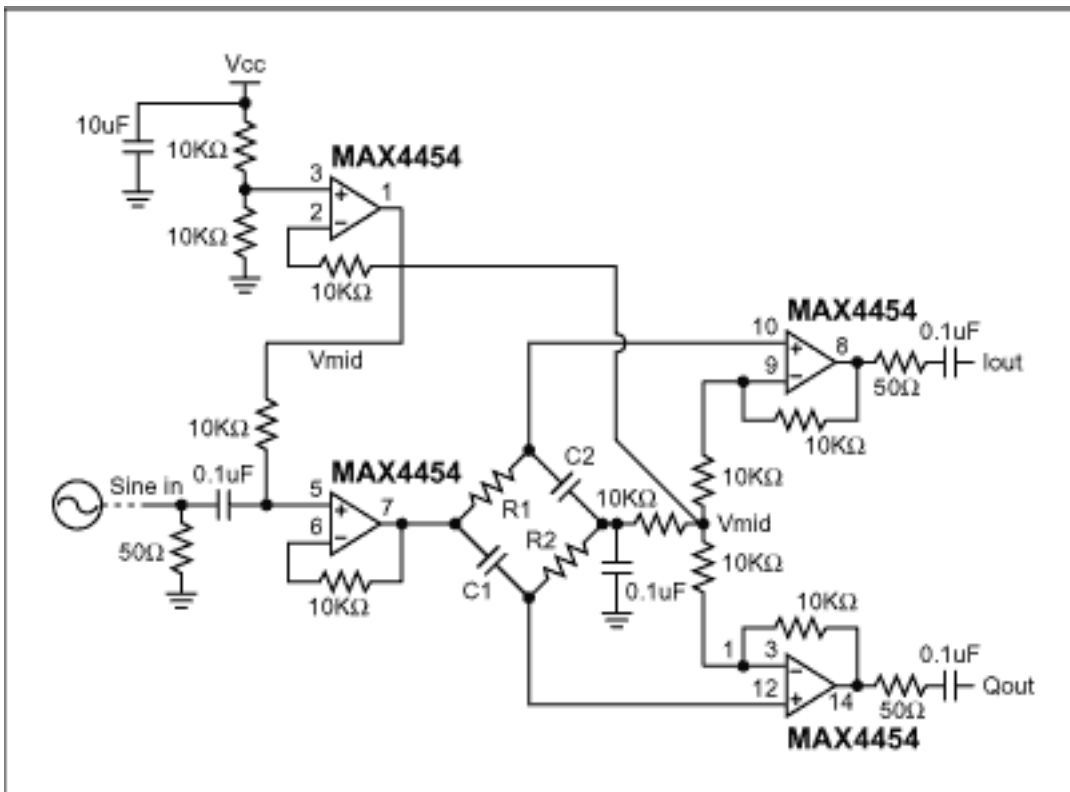

Figure 1.

Implementation: Choosing the Bridge Components

A RC low-pass section provides -45° phase lag at the -3dB cutoff, while an RC high-pass provides $+45^\circ$ lead. Therefore, if identical R's and C's are selected, the bridge will provide exactly 90° phase-shifted outputs, each 3dB lower than the input sinusoid. Of course, the circuit is very frequency dependent, and the bridge components must be as closely matched as possible, or else the output tones will not match. The proper values must also be chosen to yield an appropriate corner frequency for the radio to be tested. To design the bridge use the formula:

$$F_{\text{corner}} = 1/2 \pi RC$$

Start by determining the best baseband input frequency for your radio (generally the middle of the transmit I/Q bandwidth). Then choose a capacitor above 100pF, so that board parasitics will not dominate the bridge balance. Once these variables are determined simply solve for the resistor value. Note that the MAX4454 is a video op-amp which has impressive drive capability (i.e., several Vpp at 100MHz into 50Ω!) so the only (suggested) limitation for R value is to keep it above $\sim 100\Omega$ to minimize amplifier distortion. Table 1 gives two examples of bridges that have actually been built and used to successfully test radios.

Table 1. Bridge Components

Corner Frequency	R1 (Ω)	C1 (pf)
408.09kHz	3.9K	100
4.38MHz	336	100

When implementing the actual circuit the most critical item to remember is this: **The bridge must be balanced**. Not only should each resistor be measured, and each capacitor taken from a 'known value' lot, but all signal traces (or wires) must be as close to the same length as possible. If this area is neglected the integrity of the entire circuit is jeopardized. The photo below shows a unit built for a 408kHz corner frequency. Note the equidistant SMA connectors and their relative position to the bridge and op-amps.



Figure 2.

Performance Verification

The circuit values shown in Table 1, line 1 were originally chosen to yield a sin-cosine output at 408.09kHz. The prototype was assembled and tested using the setup shown in **Figure 3**.

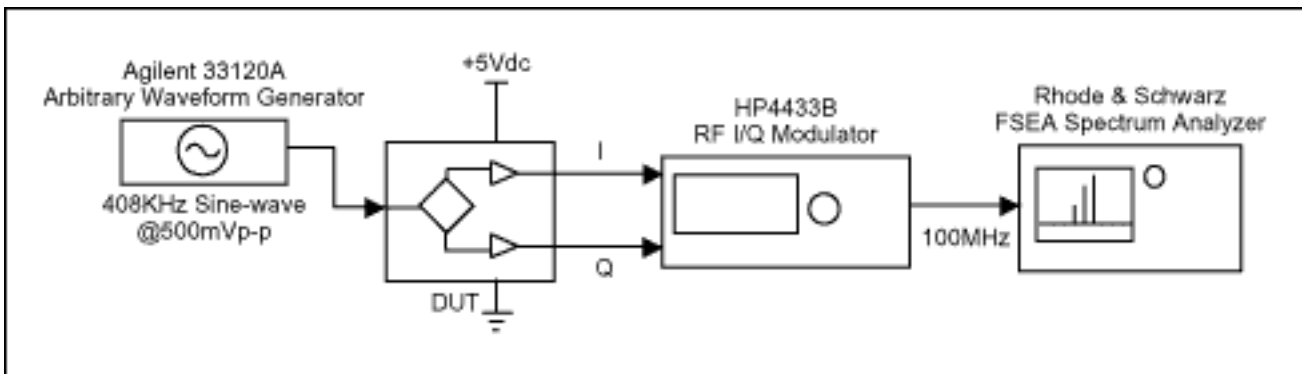

Figure 3.

The phase and amplitude balance of the I/Q generator was tested by up-conversion with a lab generator whose internal quadrature modulator offers -65dBc side-band (image) rejection, which is regarded as superb for most systems. Therefore, any imbalance observed at its output will be due to the I/Q generator circuit under test.

While monitoring the resulting RF signal with a spectrum analyzer, the input frequency was adjusted until carrier and side-band suppression were optimal. This is how the exact F_{corner} of the bridge was determined. At 408.65kHz the maximum side-band suppression was -46dBc. It is also interesting to note that since we use blocking capacitors at the I and Q outputs, the test circuit will not contribute DC offset to the modulator, hence will not degrade carrier suppression.

Application Note 1946: <http://www.maxim-ic.com/an1946>

More Information

For technical questions and support: <http://www.maxim-ic.com/support>

For samples: <http://www.maxim-ic.com/samples>

Other questions and comments: <http://www.maxim-ic.com/contact>

Related Parts

MAX4454: [QuickView](#) -- [Full \(PDF\) Data Sheet](#)

AN1946, AN 1946, APP1946, Appnote1946, Appnote 1946

Copyright © by Maxim Integrated Products

Additional legal notices: <http://www.maxim-ic.com/legal>