

Design Note:

**HFDN-24.0**

Rev.1; 04/08

---

---

***Using the MAX3735 in a Small Form Factor (SFF)  
Transceiver Module***

---

---



# Using the MAX3735 in a Small Form Factor (SFF) Transceiver Module

## 1 Purpose

The purpose of this design note is to show how the MAX3735 laser driver can be used in Small Form Factor (SFF) transmitter applications.

The SFF Multisource Agreement (MSA) specifies two versions – 10 pin and 20 pin. The MAX3735 can be easily adapted to either. Also, the MAX3735 allows dc coupling of the laser diode and has other features that enable multi-rate operation over 155Mbps to 2.7Gbps without any modifications or adjustments.

## 2 SFF Transmitter Pin Functions

The SFF MSA defines the transmitter pin functions as follows:

TABLE I. SFF Transmitter Pin Definitions

Pin Numbers		Symbol	Description
10 Pin	20 Pin		
6	11	V <sub>CCt</sub>	Power Supply
7	12	V <sub>eeT</sub>	Signal Ground
8	13	TDis	Transmitter Disable
9	14	TD+	Data In
10	15	TD-	Inverted Data In
-	16	V <sub>eeT</sub>	Signal Ground
-	17	Bmon(-)	Bias Current Monitor (neg)
-	18	Bmon(+)	Bias Current Monitor (pos)
-	19	Pmon(-)	Optical Power Monitor (neg)
-	20	Pmon(+)	Optical Power Monitor (pos)

Some applicable details from the SFF MSA are:

(a) Transmitter Disable. Transmitter disabled when high [ $(V_{CCt} - 1.3V) < V_{TDis} < V_{CCt}$ ], enabled when low [ $V_{eeT} < V_{TDis} < (V_{eeT} + 0.8V)$ ] or open circuit.

(b) Data In. 100Ω resistor between TD+ and TD- for datarates > 622Mbps, no termination resistor for 622Mbps and below.

(c) Bias Current Monitor. The laser bias current is accessible as a dc-voltage by measuring the voltage

developed across the Bmon+/- pins. Dividing the voltage by 10Ω will yield the value of the laser bias current. The stand-off resistors should be 3kΩ. At an ambient of 25°C, the voltage should range up to a maximum of 0.70 volts.

(d) Optical Power Monitor. The backface diode monitor current is accessible as a voltage proportional to the photocurrent through a 200Ω resistor between Pmon+/- pins. The stand-off resistors should be 3kΩ. At 50% duty cycle, this voltage can range between 0.01 and 0.20 volts.

## 3 MAX3735 SFF Implementation

Figure 1 is a schematic diagram of the MAX3735 connections necessary to implement a multirate SFF laser driver. It is important to note the following:

(a) The MAX3735 includes an internal 100Ω resistor between IN+ and IN-, which satisfies the SFF MSA requirement for 100Ω between TD+ and TD- at data rates > 622Mbps.

(b) The 200Ω resistor between Pmon+ and Pmon- will meet SFF MSA requirements for monitor diode currents between 50μA and 1.0mA. For monitor diode currents outside this range, the value of this resistor must be adjusted in order to be compliant with the MSA.

(c) The values of R<sub>MODSET</sub> and R<sub>APCSET</sub> determine the modulation and bias currents, respectively. See the [MAX3735 datasheet](#) for more details.

(e) The 1.3kΩ pull-down resistor on pin 24 of the MAX3735 is required to meet the SFF MSA requirement that the transmitter must be enabled when the TDis input is not connected. Because of this pull-down resistor, the circuit driving TDis must be capable of sourcing 1mA of current. Depending on the application, a buffer circuit, such as the one shown in the lower right of Figure 1, may be necessary.

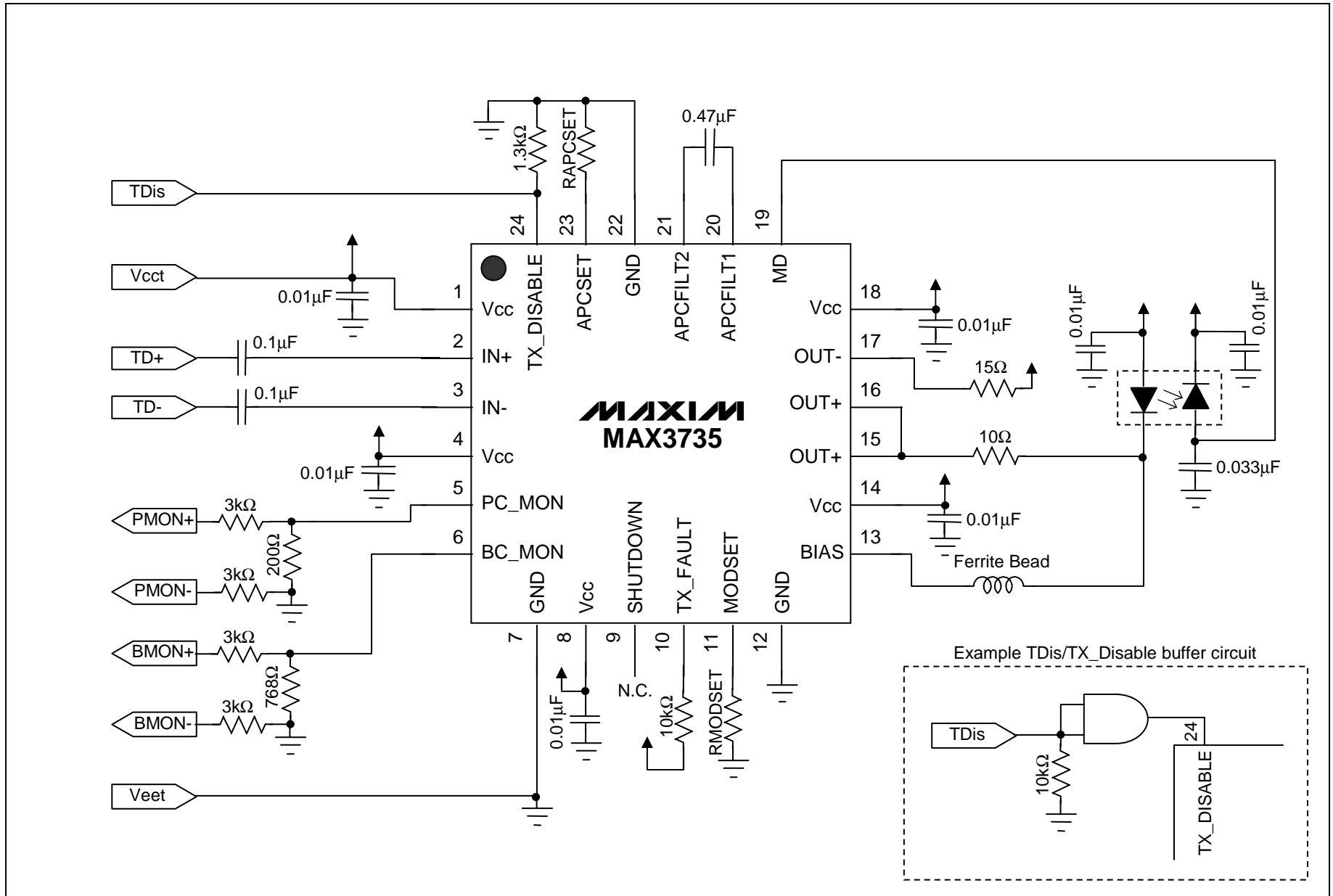

Figure 1. Schematic Diagram of MAX3735 Implementation of an SFF Laser Driver