

APPLICATION NOTE 1863

Transmit Digital Signals and Power Over Same Wires

Abstract: Analog switches can be used to enable the transmission of digital signals and power over the same two wires. The signal waveform is rectified at the remote location to provide a stable supply voltage and modest load current (about 1mA maximum) for the receiver.

This signaling system enables the transmission of digital signals and power over the same two wires (**Figure 1**). The signal waveform is rectified at the remote location to provide a stable supply voltage and modest load current (about 1mA maximum) for the receiver.

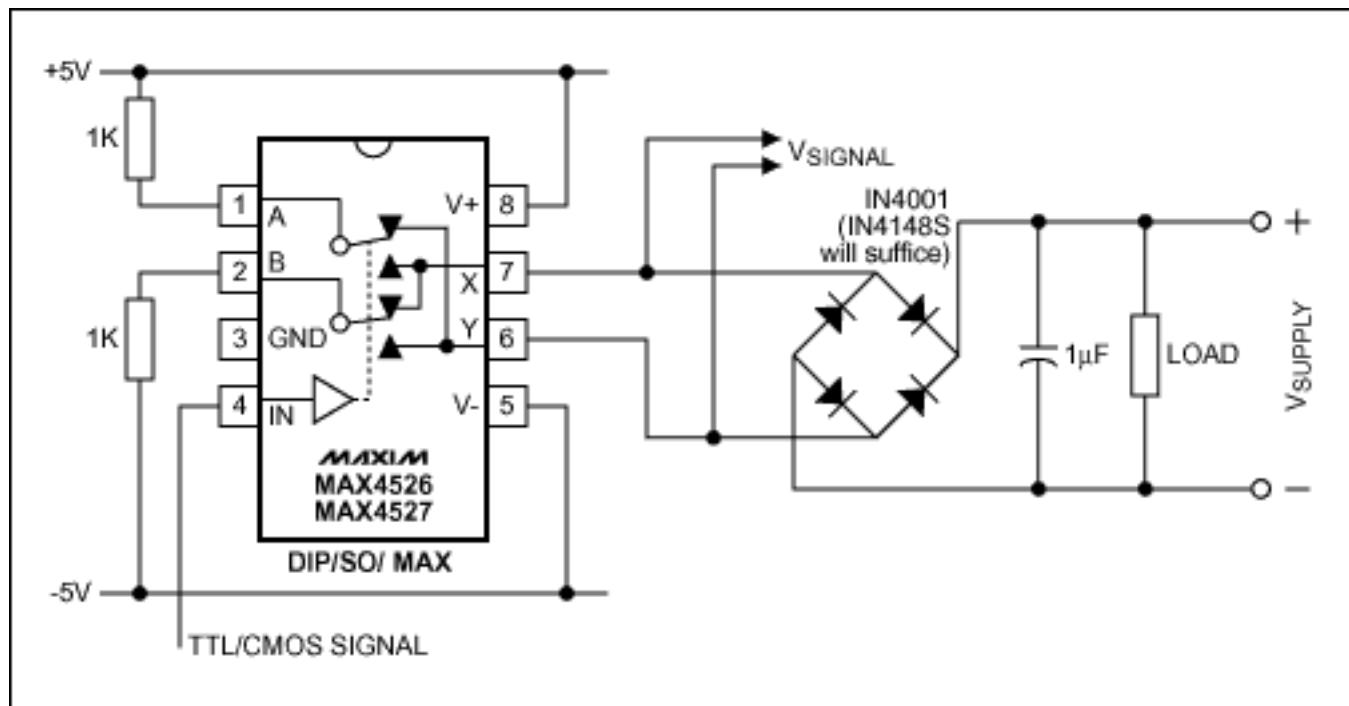

Figure 1. This digital signaling system accepts single-ended data, transmits differential data, and produces a supply voltage for the receiver by full-wave rectifying the remote-end signal.

For conventional single-ended data, a series of "0s" can allow excessive droop in the receiver's supply voltage. To avoid that problem differential data ($\pm 5V$ to $\pm 18V$) is transmitted, pseudo RS-485 style, from a single-ended logic-level input. The full-wave rectifier and differential drive ensures that a supply voltage is always present

Current-limiting resistors at the supply inputs prevent damage in the event of a line short. Values of 1k Ω are optimum. Higher values produce excessive switching noise at the chip side of the resistors, caused by charge injection from the switches. Adequate decoupling of the supply rails also helps to minimize noise.

With +5V and -5V supplies powering the MAX4526/4527 as shown in Figure 1, the measured output for various loads is as follows:

Load (Ω)	V _{SUPPLY} (V)
1M	9.60
47k	9.00
10k	8.60
8.2k	8.40
5k	8.20

Application Note 1863: www.maxim-ic.com/an1863

More Information

For technical questions and support: www.maxim-ic.com/support

For samples: www.maxim-ic.com/samples

Other questions and comments: www.maxim-ic.com/contact

Keep Me Informed

Preview new application notes in your areas of interest as soon as they are published. Subscribe to [EE-Mail - Application Notes](#) for weekly updates.

Related Parts

MAX4526: [QuickView](#) -- [Full \(PDF\) Data Sheet](#) -- [Free Samples](#)

MAX4527: [QuickView](#) -- [Full \(PDF\) Data Sheet](#) -- [Free Samples](#)

AN1863, AN 1863, APP1863, Appnote1863, Appnote 1863

Copyright © by Maxim Integrated Products

Additional legal notices: www.maxim-ic.com/legal