

## APPLICATION NOTE 1858

# Tiny IC Debounces Pushbutton Switch

*Abstract: When a push-button is used to manually reset a microprocessor ( $\mu P$ ), ringing from the switch may cause a false reset output signal when the switch is pressed and de-pressed. Maxim's microprocessor supervisors have a debounced manual reset input to help ignore this ringing.*

Though they're not complicated, schemes for debouncing a pushbutton switch usually entail using several logic gates. It's easy to include such circuits in an ASIC. Adding a debouncer as a last-minute design change, however, can be inconvenient. In such cases, the circuit in the figure below can come in handy. The circuit, using only a 4-pin SO-package IC, squares up and debounces a pushbutton signal. IC<sub>1</sub> is a reset chip with a reset output that goes high when its supply voltage drops below 2.65V or when its manual-reset input (MR-bar) goes low. MR-bar usually connects to a system-reset input, and reset connects to a  $\mu C$ , but the connections shown enable the device to debounce any signal.

The internal one-shot provides an instant response to the first falling edge on the input and then delays any further response until 140msec after the last rising edge. The MAX812 shown inverts the pushbutton input; a similar device (MAX811) is noninverting. The ICs also incorporate a power-on reset function that asserts the reset output when V<sub>CC</sub> falls below a preset threshold and also asserts the output for 140msec after each application of power. Selecting an R-suffix part sets this threshold at its lowest value (2.63V), preventing false outputs in the debouncer except when the supply voltage fails.

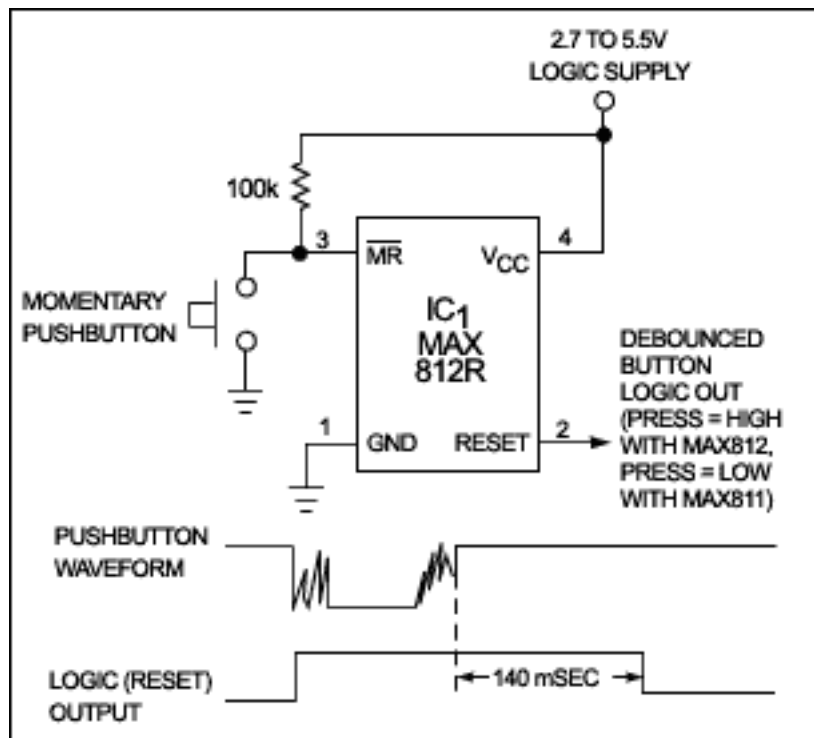

*Using almost no real estate, this circuit squares up and debounces a pushbutton signal and extends it to at least 140msec.*

A similar version of this article appeared in the April 1, 2001 issue of EDN.

Application Note 1858: <http://www.maxim-ic.com/an1858>

### **More Information**

For technical questions and support: <http://www.maxim-ic.com/support>

For samples: <http://www.maxim-ic.com/samples>

Other questions and comments: <http://www.maxim-ic.com/contact>

### **Related Parts**

MAX6384: [QuickView](#) -- [Full \(PDF\) Data Sheet](#) -- [Free Samples](#)

MAX6385: [QuickView](#) -- [Full \(PDF\) Data Sheet](#) -- [Free Samples](#)

MAX6386: [QuickView](#) -- [Full \(PDF\) Data Sheet](#) -- [Free Samples](#)

MAX812: [QuickView](#) -- [Full \(PDF\) Data Sheet](#)

AN1858, AN 1858, APP1858, Appnote1858, Appnote 1858

Copyright © by Maxim Integrated Products

Additional legal notices: <http://www.maxim-ic.com/legal>