



APPLICATION NOTE 1857

## DDR Memory-Termination Supply

Double data rate (DDR) synchronous DRAM (SDRAM) is used in high-speed memory systems in workstations and servers. These memory ICs use 2.5V or 1.8V supply voltages. They require a reference voltage equal to half the supply voltage ( $V_{REF} = V_{DD}/2$ ). Their logic outputs are terminated with a resistor to the termination voltage ( $V_{TT}$ ), which equals and tracks  $V_{REF}$ .  $V_{TT}$  must source or sink current while maintaining  $V_{TT} = V_{REF} \pm 0.04V$ .

The circuit of **Figure 1** provides the termination voltage for both 2.5V and 1.8V memory systems, and delivers up to 6A. U1 includes a step-down controller and two linear-regulator controllers, and operates with input voltages from 4.5V to 28V. Its fixed 200kHz PWM controller maintains the output voltage by sourcing and sinking current. Maximum sink current equals the maximum source current, though the sink current has no current limit. When sinking current, the device returns some current to the input supply.

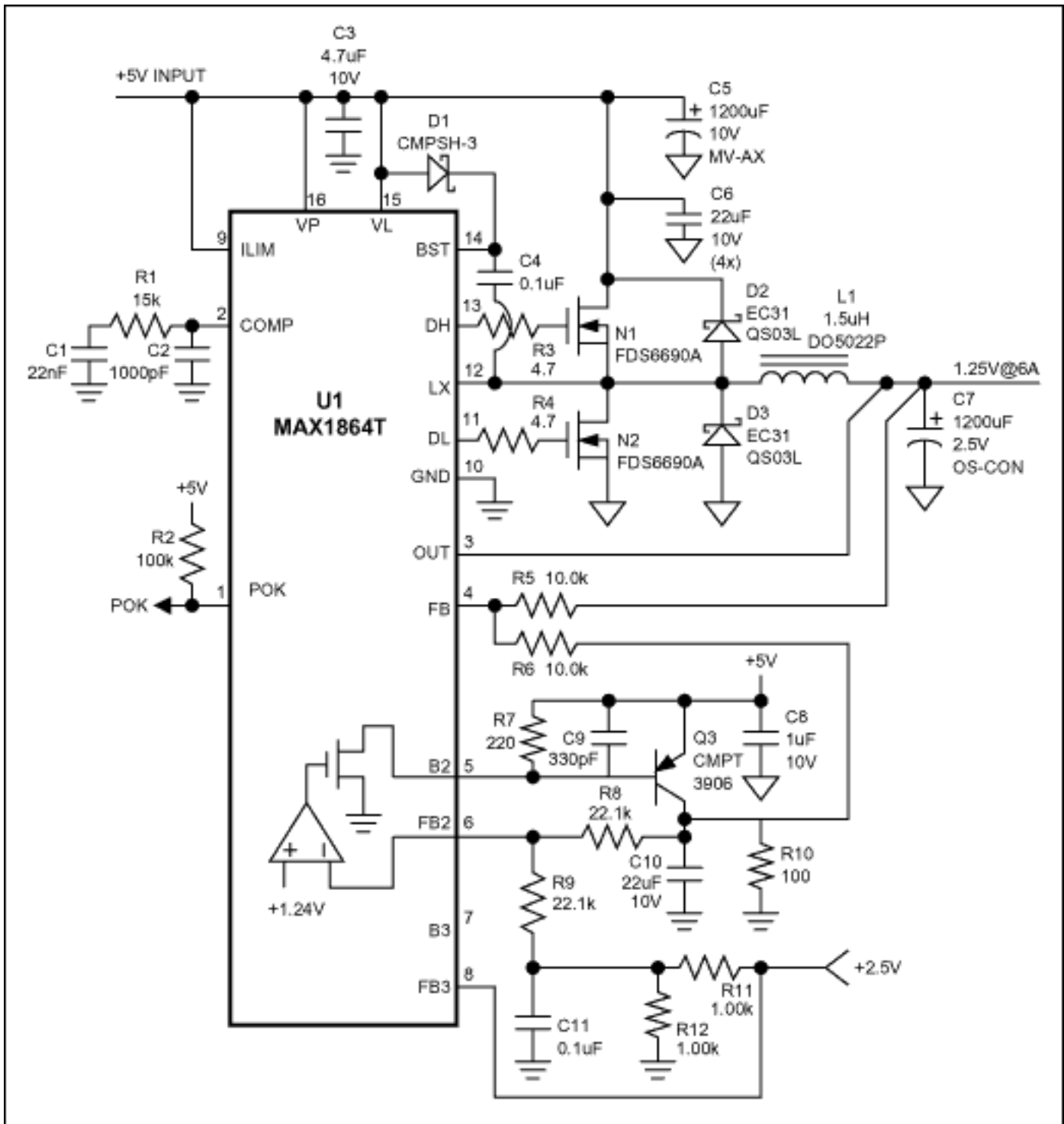

Figure 1. This circuit generates the termination voltage for DDR synchronous DRAMs.

To implement the tracking function, one of U1's extra linear-regulator controllers is configured as an inverting amplifier. This amplifier compares  $V_{DD}/2$  (created by R11 and R12) with  $V_{REF}$  from U1, and generates an error signal that is applied via R6 to U1's FB pin, thereby forcing  $V_{OUT}$  to track  $V_{DD}/2$ . A 10mA load (R10) is required to bias the inverting amplifier for accurate tracking.  $V_{OUT}$  can track  $V_{DD}/2$  for  $V_{DD}$  in the range 1V to 4V.

### More Information

For samples: [www.maxim-ic.com/samples](http://www.maxim-ic.com/samples)

Other questions and comments: [www.maxim-ic.com/contact](http://www.maxim-ic.com/contact)

---

### **Keep Me Informed**

Preview new application notes in your areas of interest as soon as they are published. Subscribe to [EE-Mail - Application Notes](#) for weekly updates.

---

### **Related Parts**

MAX1864: [QuickView](#) -- [Full \(PDF\) Data Sheet](#) -- [Free Samples](#)

AN1857, AN 1857, APP1857, Appnote1857, Appnote 1857

Copyright © by Maxim Integrated Products

Additional legal notices: [www.maxim-ic.com/legal](http://www.maxim-ic.com/legal)