



APPLICATION NOTE 1836

Improving Receiver Sensitivity with External LNA

Abstract: This application note presents the system level trade-offs involved in adding a low-noise amplifier (LNA) to a remote keyless entry (RKE) receiver. The system's sensitivity improves 3.77dB, but the third order intercept degrades by 15dB.

The sensitivity specifications indicates how well a receiver will capture weak signals. It is a key specification because and it directly affects the range of the system.

In many remote keyless entry (RKE) and tire pressure monitoring (TPM) designs, the manufacturer will quote the sensitivity of the receiver (dBm) as a means to differentiate the system from a competitor's. Other receiver parameters such as noise figure, intermodulation distortion, dynamic range or even power consumption are sometimes relegated in importance because of the importance that consumers place on sensitivity and range.

One way to improve a system's sensitivity is to add gain by connecting an external LNA. Or -- is it that simple?

Sensitivity of a receiver is based on its noise figure, the minimum required S/N ratio for detection of the modulation, and the thermal noise of the system. The equation for the minimum input signal is noted below:

$$S = NF + n_0 + S/N \quad \text{EQN1}$$

where S is the minimum input signal required (dBm), NF is the noise figure of the receiver, S/N is the required output signal to noise ratio (for adequate detection, usually based on the acceptable bit error rate), and n_0 is the thermal noise power of the receiver (dBm).

For sake of simplicity, we will estimate the required output S/N ratio (Manchester data) to be 5dB. To calculate S, we still need n_0 . n_0 is defined as:

$$n_0 = 10 \log_{10} (k T B / 1E-3) \text{ in dBm}$$

where k is the Boltzmann's constant ($1.38 \text{ E-}23$), T is temperature in Kelvin, and B is the noise bandwidth of the system. At room temperature ($T = 290^\circ\text{K}$) in a 1Hz bandwidth, $n_0 = -174\text{dBm}$ (commonly expressed as -174dBm/Hz).

For a 300kHz IF bandwidth, n_0 is calculated to be -119dBm .

Let's assume the sensitivity of our system to be -109dBm . Using EQN1, we can determine the NF of our receiver to be 5dB. Recalling the relationship between noise figure (NF) and noise factor (F):

$$(NF)_{\text{db}} = 10 \log F \text{ and } F = 10^{(NF)_{\text{db}}/10}$$

The noise factor is thus $F = 3.162$.

To find the noise factor of several cascaded two port devices, we use the following equation:

$$F_{\text{Total}} = F_1 + (F_2 - 1) / G_1 + (F_3 - 1) / (G_1 \times G_2) + \dots \quad \text{EQN2}$$

So if we add an external LNA to the input of our system, we can use EQN2 to calculate our new noise factor. The MAX2640 LNA has a NF = 1dB ($F_1 = 1.26$) and a gain of 15dB ($G_1 = 31.62$), and since the noise factor of our original system (MAX1470) was $F_2 = 3.162$, then $F_{\text{total}} = 1.327$ or 1.23dB.

What does this all mean? Using EQN1, we see that the sensitivity is now:

$$S = 1.23 - 119 + 5 = -112.77\text{db}$$

Therefore, adding the external LNA improved our sensitivity by 3.77dB only, which, depending on the requirements, may or may not be enough. However, noise figure is only part of the picture. The MAX1470 has a system IIP3 of -34dBm. This is due to the fact that the mixer IIP3 is -18dBm while the internal LNA gain is 16dB for a system IIP3 of -34dBm. Adding the MAX2640 LNA externally will reduce the system IIP3 from -34dBm to -49dBm (LNA gain is 15dB) which means that the signal-handling capability of our system has been reduced. In other words, even though the sensitivity was improved by almost 4dB, the dynamic range of the system was reduced by 15dB.

Therefore it is up to the system designer to decide whether the price paid for the extra sensitivity is worth the reduction in IIP3.

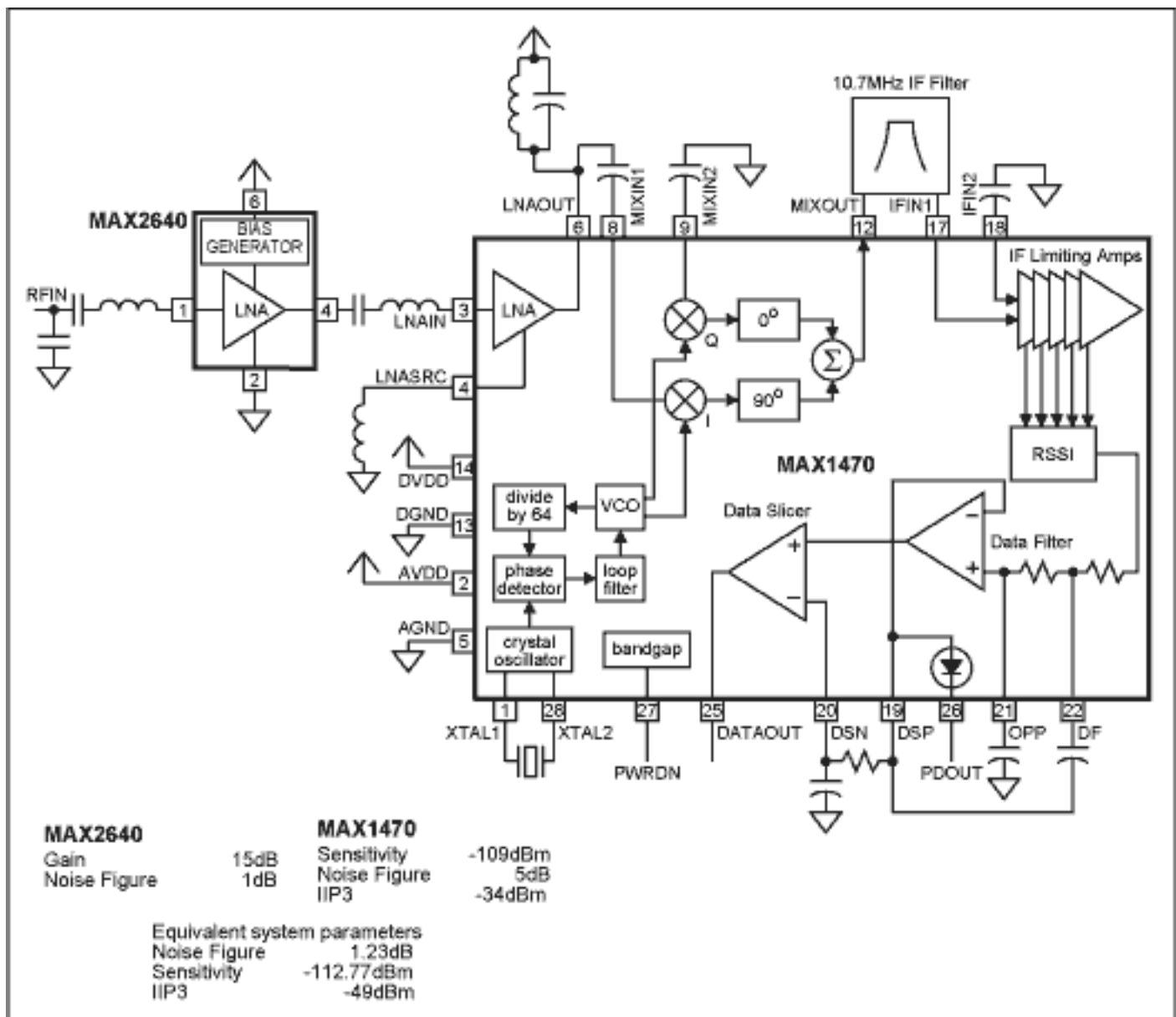

Figure 1.

Application Note 1836: <http://www.maxim-ic.com/an1836>

More Information

For technical questions and support: <http://www.maxim-ic.com/support>

For samples: <http://www.maxim-ic.com/samples>

Other questions and comments: <http://www.maxim-ic.com/contact>

Related Parts

MAX1470: [QuickView](#) -- [Full \(PDF\) Data Sheet](#)

MAX2640: [QuickView](#) -- [Full \(PDF\) Data Sheet](#)

AN1836, AN 1836, APP1836, Appnote1836, Appnote 1836

Copyright © by Maxim Integrated Products

Additional legal notices: <http://www.maxim-ic.com/legal>