



APPLICATION NOTE 1815

Add Current Boost to USB Charger Driven by an AC Adapter

Abstract: A USB interface is capable of charging a portable device while transferring data. But for high-capacity batteries, the limited output current of USB hosts and hubs greatly extends the charging time. Powered USB hubs and USB hosts supply up to 500mA. Unpowered USB hubs supply no more than 100mA. A separate AC adapter can supply charging current. The most convenient solution works from either the USB port or an AC adapter. The user can charge from a notebook USB port when traveling, and use the AC adapter, with its faster charge, when at home or in the office.

A USB interface is capable of charging a portable device while transferring data. But for high-capacity batteries, the limited output current of USB hosts and hubs greatly extends the charging time. Powered USB hubs and USB hosts supply up to 500mA. Unpowered USB hubs supply no more than 100mA.

A separate AC adapter can supply charging current. The most convenient solution works from either the USB port or an AC adapter. The user can charge from a notebook USB port when traveling, and use the AC adapter, with its faster charge, when at home or in the office.

An external transistor current source (**Figure 1**) adds dual-input capability to a single-chip lithium-cell charger. The chip (U1) operates alone when USB power is connected, and is pin-programmed for a maximum charging current of either 500mA or 100mA. When you plug in an AC adapter (set for 600mA by the components shown), the external transistor current source (Q2 and Q3) turns on and sets the U1 charging current to 500mA. Because U1 and Q2 both charge the battery under that condition, the total charging current is 1100mA.

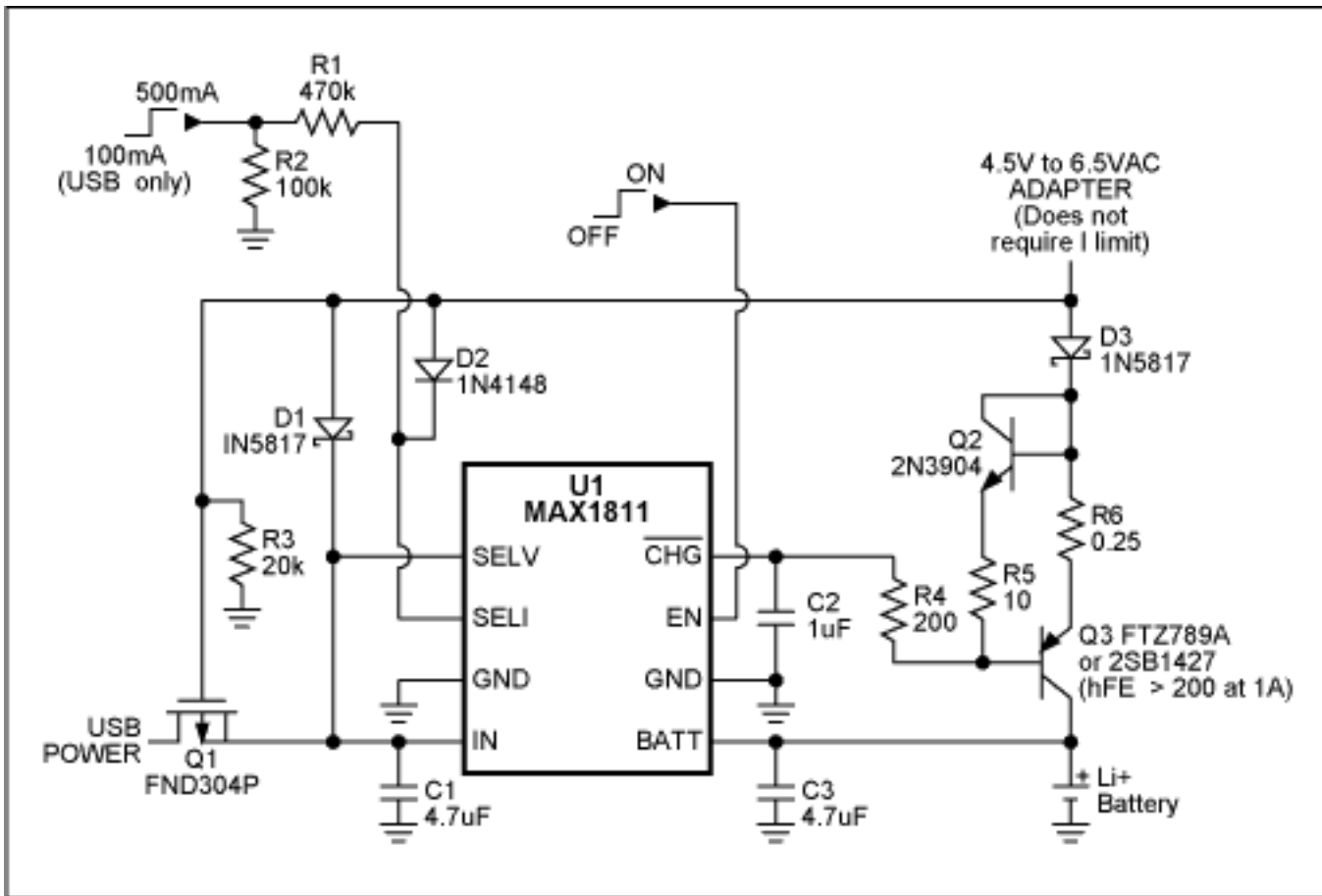

Figure 1. This battery charger delivers 100mA or 500mA (selectable) to a single lithium cell when USB power is connected, and charges at 1100mA (settable via R6 or R5) when AC power is present.

Q2 and Q3 form a current limiter for the AC adapter that allows Q2 and R6 to pass the additional 600mA. When the voltage drop across R6 exceeds that across R4 (set by R4 and R5) Q2 begins to turn off. V_{BE} cancellation by Q2 enables R6 to set the maximum current more accurately. Voltage across R5 sets the reference voltage, and output current is limited when the voltage drop on R6 matches the voltage on R5.

Q3 should have a reasonably high beta (>200 at 1A) so that U1's CHG pin can sink enough to turn on Q3. High beta also minimizes error in the transistor current-source. When U1 makes a transition from current mode to voltage mode (at approximately 4.15V), U1's CHG output turns off the transistor current source. U1 remains on and finishes off the taper to full charge. It also remains on and continues to function when USB power is gone and only AC power remains.

U1 also controls the prequalification current, which is the current level necessary to safely recover deeply discharged cells at low battery voltage. The CHG-bar output assumes a high-impedance state during cell prequalification to ensure that the external current source remains off, and that the prequalification current (about 50mA) comes only from U1.

When AC power is plugged in, Q1 turns off to prevent back-feeding the USB input. Q1 is installed "backwards" (drain connected to USB input side) so that USB power remains connected to the IN terminal (U1 pin 4) via Q1's body diode, even when Q1 is off.

A similar version of this article appeared in the September 19, 2002 issue of *EDN* magazine.

Application Note 1815: www.maxim-ic.com/an1815

More Information

For technical questions and support: www.maxim-ic.com/support

For samples: www.maxim-ic.com/samples

Other questions and comments: www.maxim-ic.com/contact

Keep Me Informed

Preview new application notes in your areas of interest as soon as they are published. Subscribe to [EE-Mail - Application Notes](#) for weekly updates.

Related Parts

MAX1811: [QuickView](#) -- [Full \(PDF\) Data Sheet](#) -- [Free Samples](#)

AN1815, AN 1815, APP1815, Appnote1815, Appnote 1815

Copyright © by Maxim Integrated Products

Additional legal notices: www.maxim-ic.com/legal