

APPLICATION NOTE 1800

Smart IC Maintains Uniform Bias Current For GaAs MESFETs

A current sensor that monitors the drain-source current (I_{DS}) at the source of the MESFET and provides feedback to the gate input overcoming the drawbacks of gate-turn-on threshold voltage variations for gallium-arsenide metal-semiconductor field-effect transistors, GaAs MESFETs.

The gate-turn-on threshold voltage for gallium-arsenide metal-semiconductor field-effect transistors (GaAs MESFETs) varies considerably from part to part, even within a given lot. That behavior makes biasing difficult, especially if the device is designed into a high-volume product. A current sensor that monitors the bias current and provides feedback to the gate input can overcome this drawback (**Figure 1**).

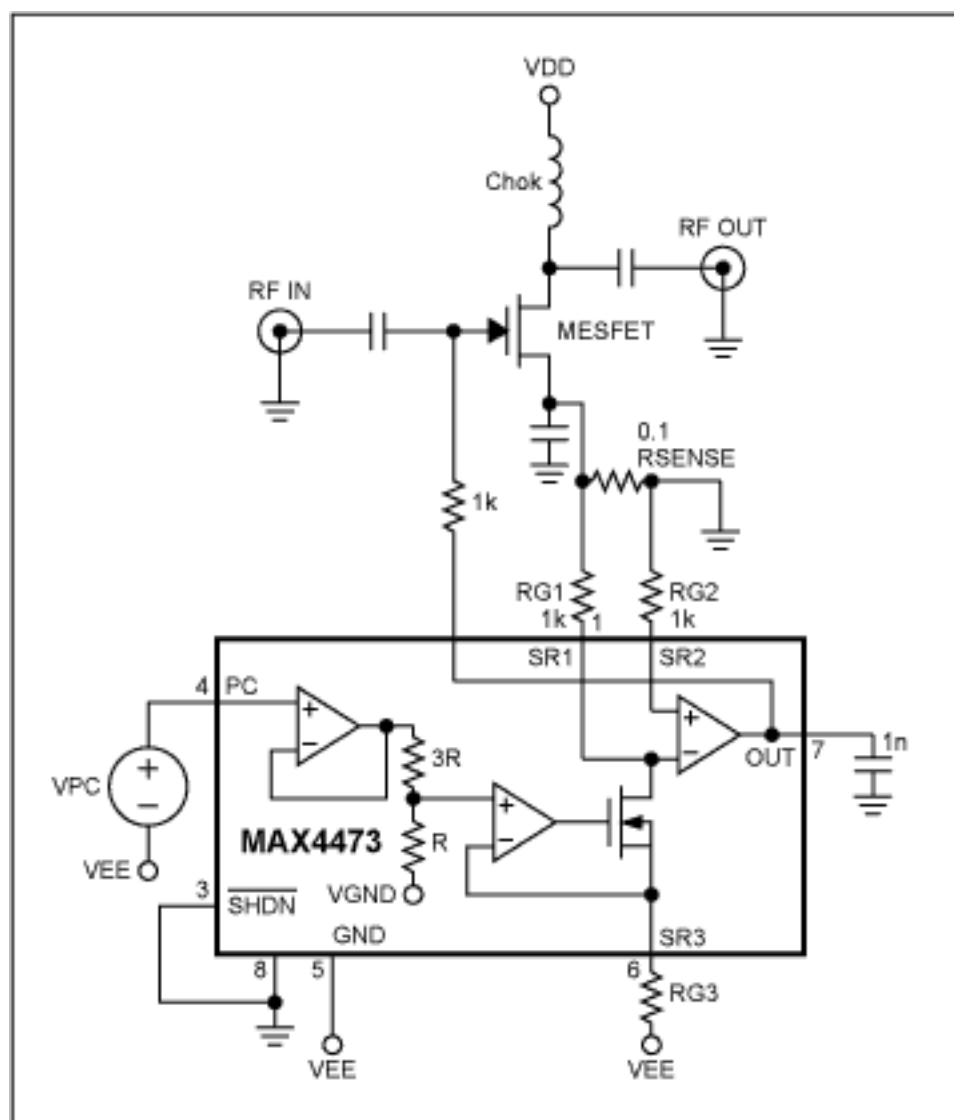

Figure 1. A smart-bias IC ensures uniform bias for GaAs FETs included in the manufacture of high-volume products.

U1 combines a current sensor and error amplifier. Intended as a power-control IC for power amplifiers, it senses the drain-source current (I_{DS}) at the source, compares and integrates the difference between voltage drops across R_{SENSE} and R_{G1} , and feeds back an output voltage to the MESFET gate. The feedback adjusts I_{DS} until the two voltage drops are equal, thereby achieving uniform source current regardless of the MESFET's gate-threshold characteristics. The expression for drain-source current is:

$$I_{DS} = \frac{V_{PC} \cdot R_{G1}}{4 \cdot R_{G3} \cdot R_{SENSE}}$$

Current through R_{G1} is set by a voltage (V_{PC}) with respect to the negative supply (VEE), applied to the power-control input at pin 4. You can implement V_{PC} with a voltage divider, a reference, or a variable voltage source. Because the gate voltage is negative with respect to the source, you must modify U1's supply voltage to ensure a negative gate drive for the MESFET: connect the VCC pin to ground and the GND pin to VEE . This uniform bias circuit can easily be modified for biasing BJTs and MOSFETs as well.

A similar version of this article appeared in the August 22, 2002 issue of *EDN* magazine.

Application Note 1800: <http://www.maxim-ic.com/an1800>

More Information

For technical questions and support: <http://www.maxim-ic.com/support>

For samples: <http://www.maxim-ic.com/samples>

Other questions and comments: <http://www.maxim-ic.com/contact>

Related Parts

MAX4473: [QuickView](#) -- [Full \(PDF\) Data Sheet](#) -- [Free Samples](#)

AN1800, AN 1800, APP1800, Appnote1800, Appnote 1800

Copyright © 2005 by Maxim Integrated Products

Additional legal notices: <http://www.maxim-ic.com/legal>