

Keywords: 3-pole, butterworth, active filter, low pass filter, video, output, NTSC, PAL, reconstruction filtering, operational amplifier, op amp Dec 04, 2002

APPLICATION NOTE 1799

5MHz, 3-Pole, Low-Pass Filter plus Video Line Driver for Consumer Video Applications

Abstract: The MAX4390 operational amplifier configured in a 3-pole, low-pass Sallen-Key filter that provides a Butterworth response with a bandwidth of -3dB at 5.25MHz. This circuit can be used for video anti-aliasing and reconstruction filtering for composite (CVBS) or S-Video signals in standard definition digital TV (SDTV) applications. The circuit is designed to drive a 75Ω termination, common in video applications, with an overall gain of 1.

The Sallen-Key realization of a 5.25MHz, 3-Pole Butterworth filter shown in **Figure 1** has a gain of 2V/V and is capable of driving 75Ω back-terminated coax to an overall gain of 1. Used to reconstruct component-video (Y, Pb, Pr) and RGB signals, this filter has an insertion loss of >20db at 13.5MHz and >40db at 27MHz (**Figure 2**). Like the anti-aliasing filter before an ADC, this filter is used to remove the higher-frequency replicas of a signal following a DAC.

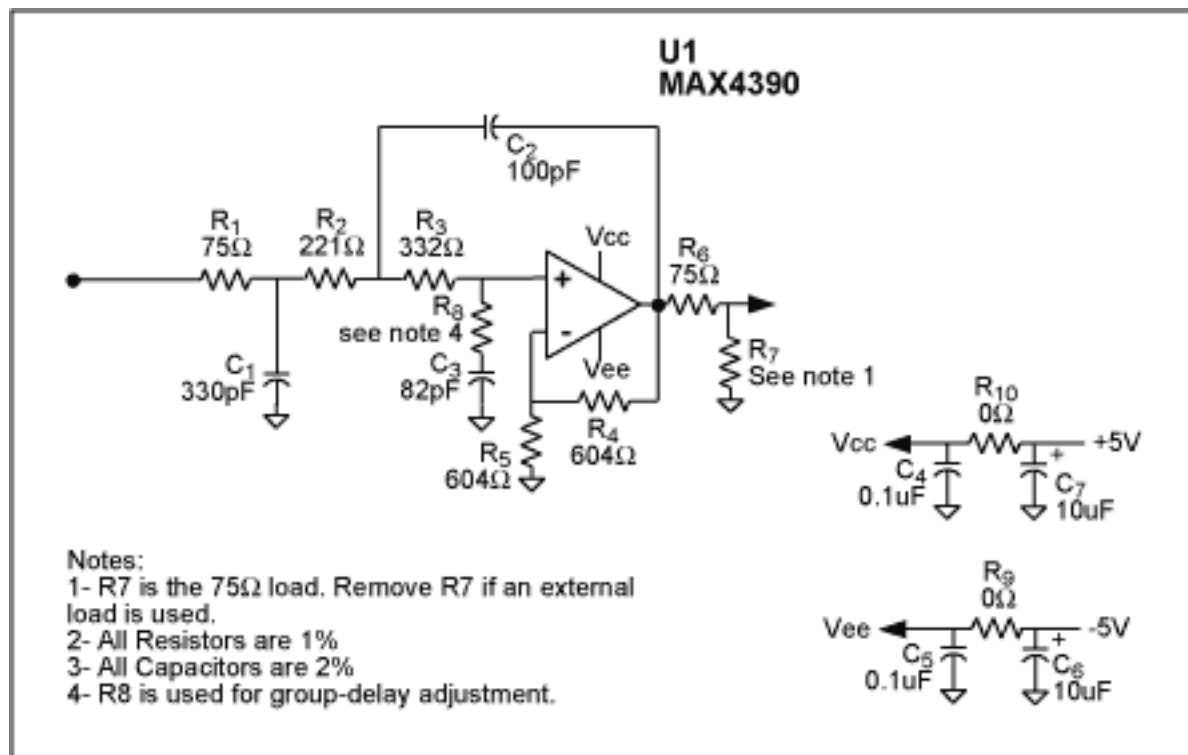

Figure 1. This 3-pole Butterworth video-reconstruction filter has adjustable group delay.

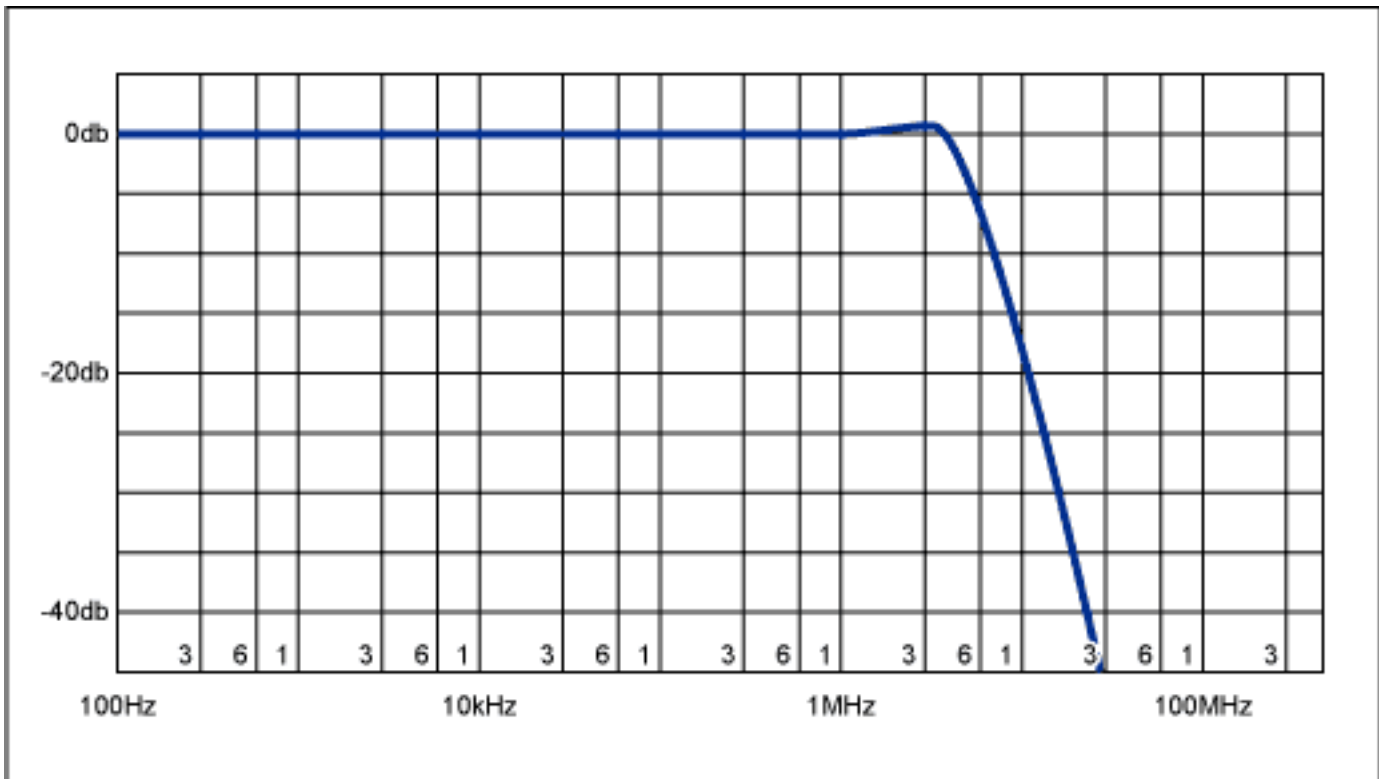

Figure 2. Typical filter response for circuit of Figure 1 with $R3 + R8 = 332\Omega$.

To preserve quality in the video waveform, one should minimize group-delay variations in the filter and also any group-delay differential between filters. That capability requires a means for adjusting the filter's group delay without affecting its bandwidth. In Figure 1, the addition of $R8$ in series with $C3$ and $R3$ creates a lag-lead network. Keeping the sum of $R3$ and $R8$ constant and equal to the original $R3$ value preserves bandwidth by preserving the dominant-pole frequency. Increasing the $R3$ value, on the other hand, introduces a "lead" term that lowers group delay by reducing the rate of change in phase.

For $R8 = 0\Omega$ and $R3 = 332\Omega$ in the circuit shown, the average group-delay variation over the filter bandwidth is about 25ns. Raising $R8$ to 31.6Ω and lowering $R3$ to 301Ω drops the variation to about 15ns, and setting $R8 = 59\Omega$ with $R3 = 274\Omega$ drops it to about 7ns. The last case affects band-edge selectivity slightly ($<0.5\text{dB}$), but does not change the filter's -3dB bandwidth. These group-delay variations are shown in Figure 3.

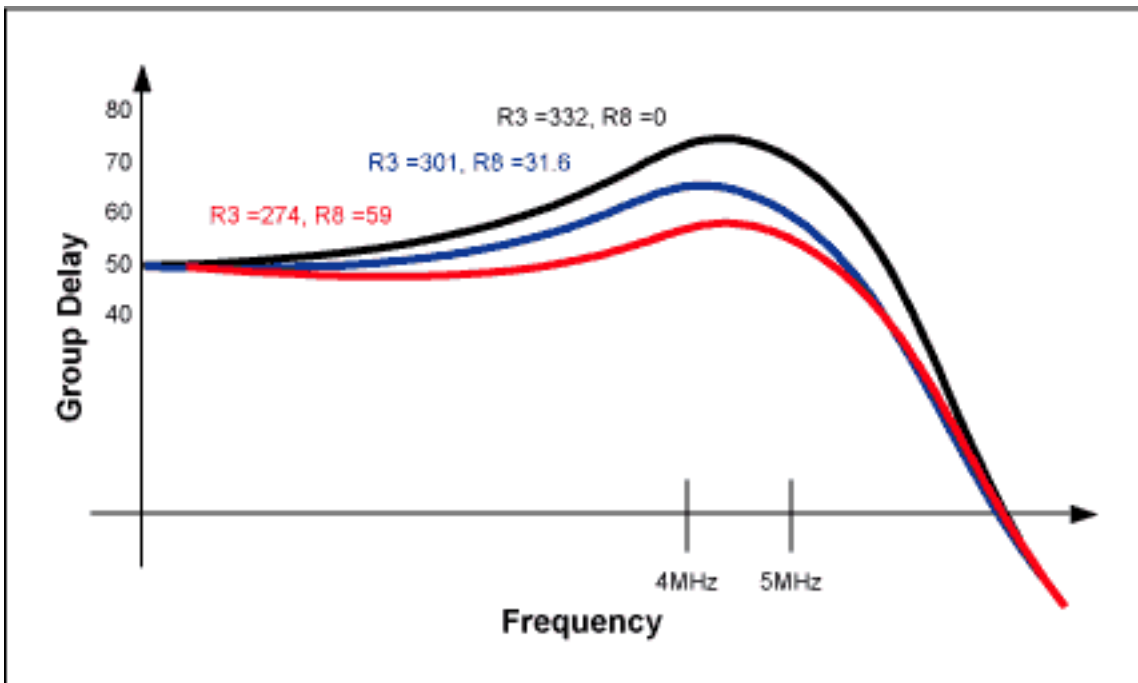

Figure 3. Selected values of $R8$ and $R3$ (see text) allow control of group-delay variation over the filter's passband.

A similar version of this article appeared in the August 8, 2002 issue of *EDN* magazine.

Application Note 1799: www.maxim-ic.com/an1799

More Information

For technical questions and support: www.maxim-ic.com/support

For samples: www.maxim-ic.com/samples

Other questions and comments: www.maxim-ic.com/contact

Keep Me Informed

Preview new application notes in your areas of interest as soon as they are published. Subscribe to [EE-Mail - Application Notes](#) for weekly updates.

Related Parts

MAX4390: [QuickView](#) -- [Full \(PDF\) Data Sheet](#) -- [Free Samples](#)

AN1799, AN 1799, APP1799, Appnote1799, Appnote 1799

Copyright © by Maxim Integrated Products

Additional legal notices: www.maxim-ic.com/legal