



APPLICATION NOTE 1798

Frequency Undersampling in Coulomb-Counting: Measuring Current Flow in Battery Applications

Coulomb counting is a technique for measuring net current flow by counting the passing charge. It is particularly valuable for fuel-gauge applications which track the charge state of a rechargeable battery.

Fuel gauge circuits for nearly all battery-powered portable equipment use a very low value series resistance as a current sensor, then converts the series voltage drop to a digital quantity using an analog-to-digital converter (ADC). Delta-sigma ADCs, and especially voltage-to-frequency converters (VFC), became popular because of claims about the need to integrate high-frequency signal components. These claims imply that discrete sampling ADCs are not accurate for this application.

This article describes the application of coulomb-counting in portable, battery-powered equipment and presents sampling theory, current diagrams, and test data to show how discrete sampling ADCs can accomplish accurate coulomb-counting.

Coulomb Counting in Portable Equipment: Requirements

First, it is important to understand that the purpose of the measurement system in a coulomb-counting application is to accurately track the net flow of current into and out of the battery. Although current waveforms in portable equipment are complex, only the integral of the current waveform is of interest. Waveform reconstruction is unnecessary. Therefore, all frequency information can be discarded as long as an accurate count of the net charge is maintained.

A second requirement for portable applications is low impact on battery life. Since the measurement system is required to operate continuously, the power consumed by the coulomb counter must be limited to less than 0.5mW. The value of the sense resistor needs to be small compared with the total series resistance of the battery pack, to minimize I^2R losses...

The third requirement for accurate coulomb counting in most portable systems is a large dynamic range. Typically, portables operate with at least two power levels: a standby or low-power mode where activity is low or performed periodically; and a high-power level where the device performs its intended task.

Usually, the high-power mode is invoked briefly between long periods of operation in the low-power mode. In mobile phones, the high- and low-power modes are termed talk and standby modes, respectively. Like mobile phones and other wireless devices, most portable products switch automatically between power modes and have no method to signal the coulomb counter. This requires the current-measurement system to account for low-current levels over long periods of time as well as high-current levels over shorter periods with unpredictable switching between modes. A dynamic range of 35dB to 45dB may be required and linearity across the dynamic range is needed to accurately accumulate the current flow captured in all operational modes.

The measurement system must be implemented in a very low-power circuit to conserve battery energy. But low-power circuits are more susceptible to noise.

As the resistance of the battery-cell and its protection-circuit fall, so do the signal levels the coulomb counter is required to measure. Acceptable sense resistor values in the 10m Ω to 30m Ω range result in low-power mode current-sense signals in the tens of microvolts. To achieve coulomb-count accuracy in standby mode over several days, resolution and input offset errors must be less than 20 μ V. This is because 96mAh accumulates each day given a 25m Ω resistor and 100 μ V of combined resolution and input-offset error. A fully charged 650mAh battery would appear to drain completely when left disconnected for a week, or worse still, a discharged

battery would appear to become fully charged.

Wireless Handset Current Waveforms

The current waveforms found in digital wireless handsets that conform to the GSM and CDMA wireless standards exhibit the two-power mode behaviors described above. But they are particularly challenging since the power amplifier (PA) transmits in short bursts, and the PA current dominates other load components. The high-power mode of a digital handset consists of repetitive current pulses for each transmission burst while a call is in progress. In standby, the PA is pulsed at a much lower rate to answer the periodic paging of the cell tower. Paging intervals typically range from 0.5s to 2s. Besides the pulse-rate variation, pulse amplitude varies in both talk and standby modes. This is because PA power is adjusted to correspond to receive power, which is primarily related to the distance of the handset to the cell tower.

GSM/GPRS

The GSM standard defines a 4.615ms frame consisting of eight time slots on each channel. Time slots are shared, so that each GSM handset operating on a channel uses one slot for transmit and one for receive. When a call is in progress, the PA current exhibits a pulse waveform with a 12.5% duty cycle as shown in **Figure 1**.

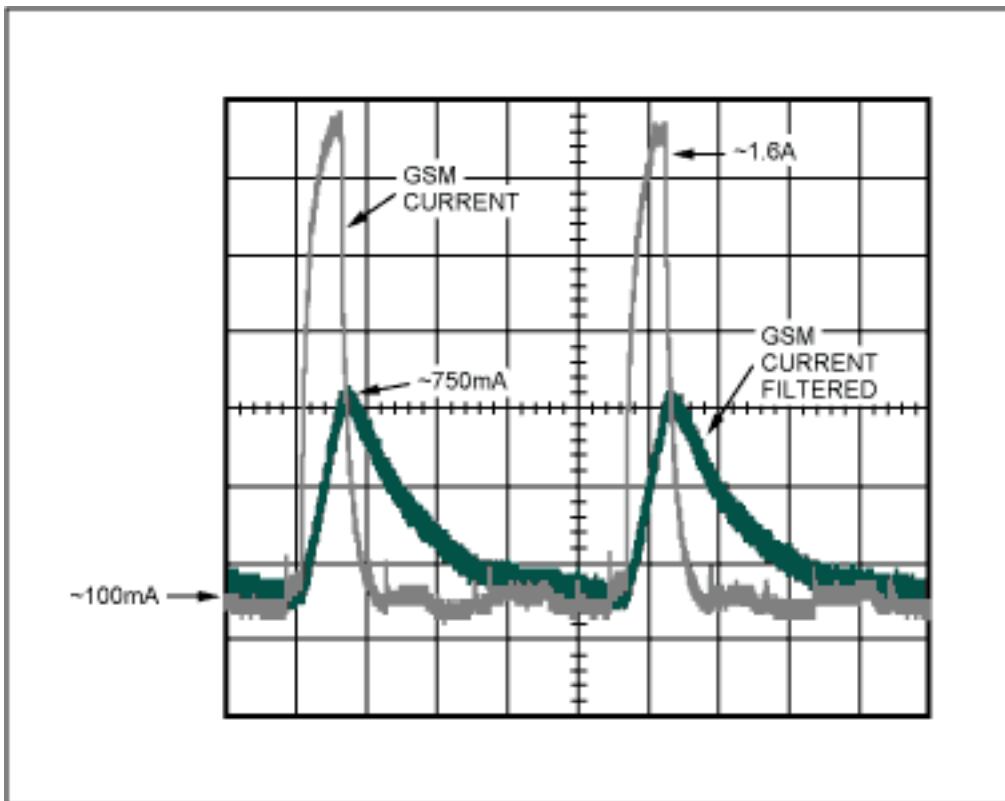

Figure 1. A GSM handset current indicates full signal strength during a voice call.

Typical and worst-case PA currents are 1A and 3A, respectively. Figure 1 was taken from a GSM handset indicating full signal strength during a call. The voltage across the filter capacitor is the signal presented to the ADC of the discrete-sampled device.

The GPRS standard implemented on a GSM network uses additional slots to increase the data rate. Additional slots are assigned for receive or transmit. When data are being uploaded from the handset to the network, up to four slots can transmit data under GPRS class 12. The battery current of a handset operating in GPRS class 12 would exhibit a 50% duty cycle since the PA transmits in four consecutive slots.

CDMA

The CDMA standard defines a 20ms frame divided into 16 power control groups. Each group has a period of 1.25ms, and various combinations of the 16 are used depending on the data rate. The PA transmitter power is varied from one 1.25ms period to the next. If the period is not used to transmit data, the power is dropped by as much as 20dB. The current waveform of a CDMA PA has a worst-case maximum amplitude of 600mA, so it is less challenging from a coulomb-counting perspective.

Theory of Undersampling

While not meeting the strict definition of the intentional undersampling technique used for frequency down-conversion and waveform reconstruction, uncorrelated undersampling near the signal frequency accurately captures the average value (DC content) of a repetitive signal. By definition, the DC value of a repetitive signal does not depend on frequency or phase and, which can be seen from the Fourier series:

$$f(t) = A_0 + A_1 \sin(\omega_1 t + q_1) + A_2 \sin(\omega_2 t + q_2) + \dots + A_n \sin(\omega_n t + q_n)$$

The average value of $f(t) = A_0$ for all A_n , q_n , and t . As long as the sample rate is not a harmonic of the energy carrying frequencies, it is unimportant when the signal is stationary (i.e., when A_0 is constant). Using a square wave as an example, the DC value represented by A_0 does not change with frequency; undersampling at any frequency other than the fundamental or a multiple of its harmonics will capture a square wave of lower frequency with the same DC content.

To achieve the goal of coulomb counting, accurate measurements of the average signal value can be obtained through undersampling, even if the signal of interest exhibits low-frequency, nonrepetitive components, or distinct modes of DC content. When compared to the sample frequency, undersampling is valid even if the low-frequency components are below the Nyquist sample rate or the discrete modes persist for long periods. Consider the square-wave example and imagine the duty cycle is modulated by a signal 1/10 the sample frequency. The sampler could discard 8 of 10 samples and still faithfully reproduce the modulating signal. Next, imagine the duty cycle rotating slowly but randomly through three discrete modes: 50% to 10% to 1%. The DC value of each mode is different and important, but as long as each mode persists long enough compared to the sample rate, the signal can be considered stationary during each mode. In both cases, the DC content can be accurately measured.

While timebase errors are important for undersampling techniques applied to both waveform reconstruction and coulomb counting, waveform recovery using intentional undersampling is sensitive to distortion due to sample-to-sample jitter. A high-quality timebase with low drift and low jitter is critical to the performance of such systems. However, since frequency and phase information are unimportant in coulomb counting, a timebase that maintains an accurate interval from sample-to-sample is not required, but the average frequency must be stable and the net clock jitter must have a zero mean. Also, to remain uncorrelated, the sample frequency, including worst-case drift, cannot equal the signal frequency or its harmonics. The timebase must maintain long-term frequency stability with zero mean jitter for accurate measurement of the DC content.

Test Results

To illustrate the effectiveness of a discrete-sampled measurement device in a pulsed-current coulomb-counting application, the DS2761 high-precision battery lithium-ion (Li+) monitor with an internal 25mΩ sense resistor was used. The test setup utilized is shown in **Figure 2**. The experiment was performed with a 700mAh prismatic Li+ cell. An Arbin battery test system was used for charging the cell and for GSM load simulation.

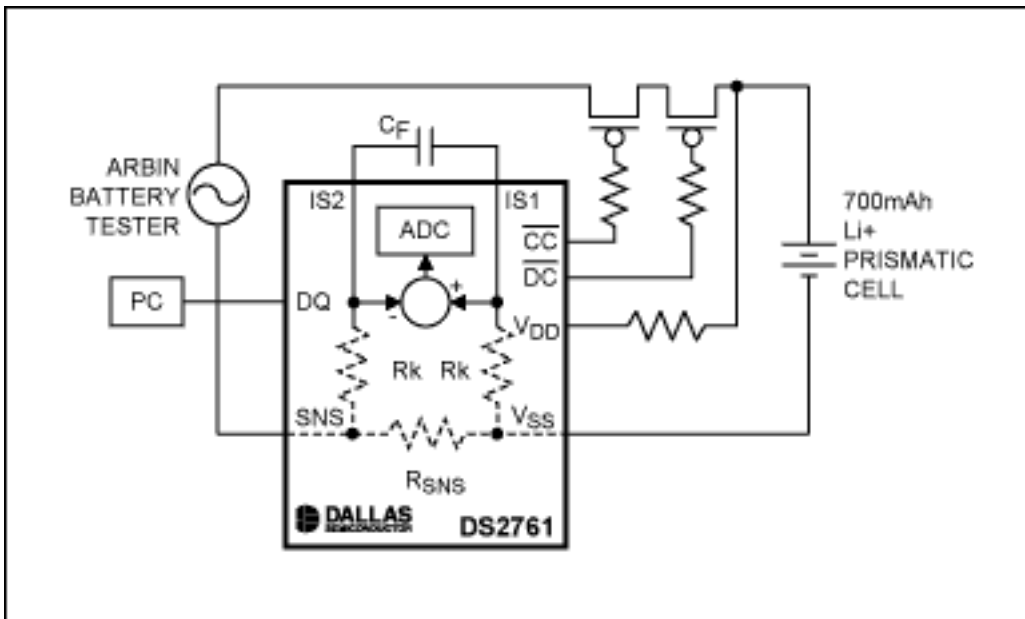

Figure 2. The effectiveness of a discrete-sampled coulomb counter in a pulsed-current application can be demonstrated in the lab using a simulated GSM or CDMA load from an Arbin battery tester.

The Arbin was programmed to perform the following pattern. The cell is fully charged by a constant current/constant voltage (CC/CV) method, then fully discharged under a continuous GSM load. It is then recharged again, and finally discharged under a DC load equivalent to the average of the GSM load. A PC recorded DS2761 data (real-time current, temperature, cell voltage, and accumulated current) approximately every 5s. This profile was performed once with a prefilter capacitor ($C_F = 0.1\mu\text{F}$) and then repeated without the capacitor to investigate the effect of the prefilter lowering the amplitude of the waveform presented to the ADC, as shown in Figure 1.

For the charge cycle, the cell was charged at 0.7C (490mA) constant current until the cell voltage reached 4.2V. The cell was then topped off under constant voltage at 4.2V until the charge current dropped below 0.1C. The GSM load was simulated with a 2.0A peak current for 550 μs and a period of 4.6ms (12% duty cycle). The current between pulses was programmed to 100mA. Thus, an average current of 327mA resulted from the GSM waveform. The cell was considered fully discharged when its voltage reached 3.0V.

Results from the experiment are presented in two ways. **Figure 3** displays the DS2761 accumulated current register (ACR) value as a function of time over the charge, CC discharge, and GSM discharge cycles. The two waveforms represent the ACR with and without the prefilter capacitor. In this experiment, no correction was made to the ACR at the end points of each charge/discharge cycle, although this is commonly done in practice by fuel-gauging algorithms (refer to [App Note 131: Lithium-Ion Cell Fuel Gauging with Dallas Semiconductor Devices](#)).

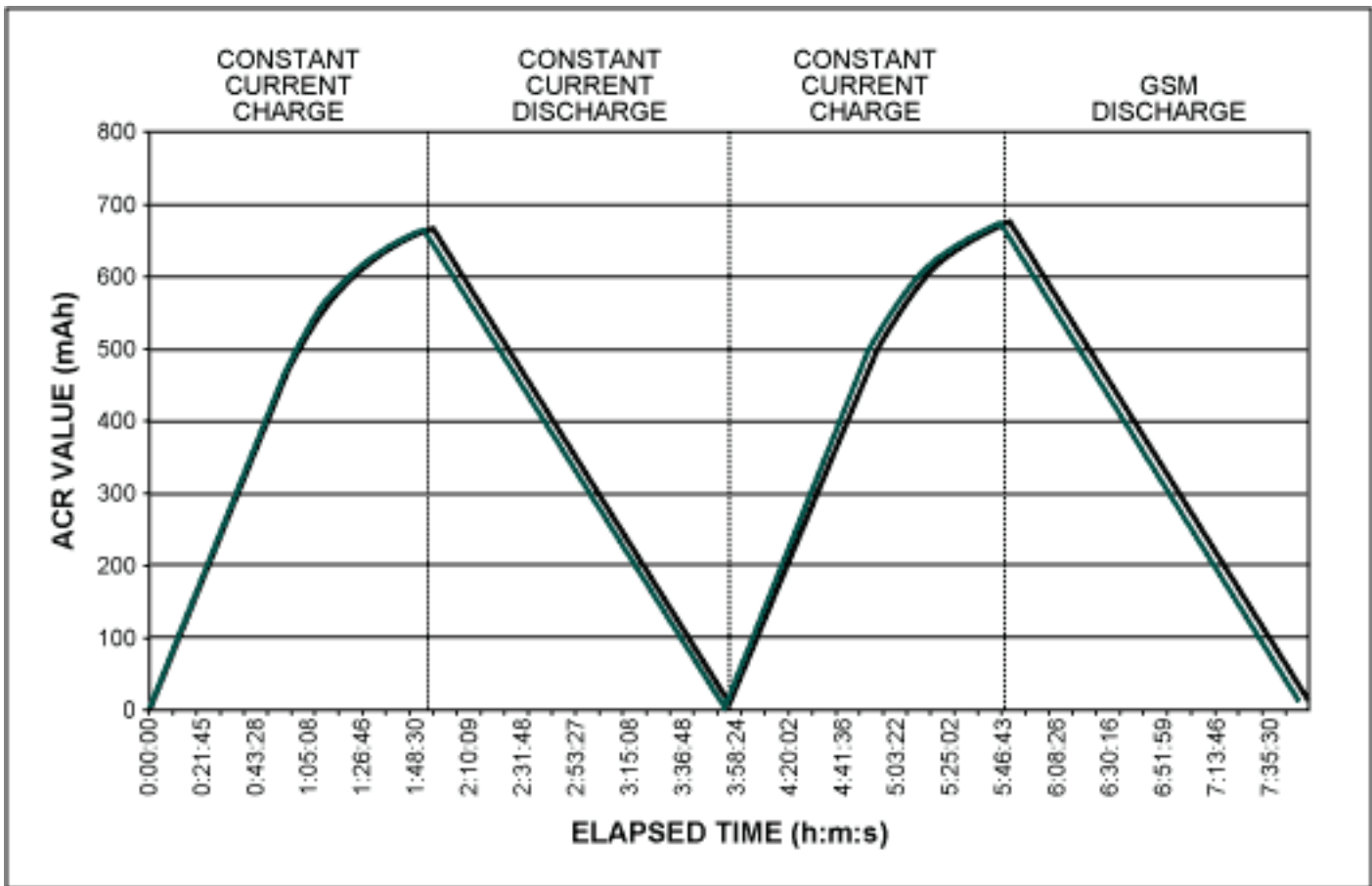

Figure 3. The two waveforms illustrate the DS2761 ACR valve with and without the prefilter capacitor.

If there were no input offset or resolution errors and if the cell's charging efficiency was 100%, one would expect the value of the ACR to return to zero every time the cell was fully discharged. In practice, measurement errors and cell-charge inefficiencies contribute to the errors that appear in the ACR value at each charge/discharge endpoint shown in Table 1.

Table 1. ACR Value at Charge and Discharge Endpoints

Endpoint	Filtered		Unfiltered		Filter Delta	
	Elapsed Time	ACR	Elapsed Time	ACR	Elapsed Time	ACR
CC/CV Charge	1:51:27	664.94	1:54:24	665.69	0:02:57	0.11%
CC Discharge	2:01:20	657.11	2:01:08	656.62	0:00:12	-0.07%
CC/CV Charge	1:52:13	664.71	1:53:12	665.69	0:00:59	0.14%
GSM Charge	2:00:57	660.54	2:01:12	659.69	0:00:19	-0.18%
CC/GSM Delta	0.32%	-0.49%	0.11%	-0.39%		

Note: It is beyond the scope of this article to discuss gain, offset, resolution, charge efficiency errors, and other factors that contribute to the ACR not always returning to the same point. This will be addressed for discrete-sampled and other measurement topologies (sigma-delta, VFC) in a future edition of the *Maxim/Dallas Semiconductor Engineering Journal*. This article seeks to validate frequency undersampling in coulomb-counting applications with pulsed waveforms, so the last row of data in the table is of most interest.

With the prefilter, the time difference in discharging a full cell under pulsed-GSM load and a DC load equal to the average of the GSM waveform was 23s, or 0.32% of the total discharge time under DC load. The difference between what the ACR decremented under these two loads was 3.43mAh, or 0.49%, of the rated cell capacity. The discharge time and ACR deltas were actually lower for the case with no prefilter, at 0.11% and 0.39%, respectively.

Table 1 illustrates the deviation at the endpoints, but the cycle times differed depending upon the discharge

profile and whether a filter capacitor was used. **Figure 4** expands on that by highlighting the ACR difference between the GSM and CC discharge cycles as a function of time, with and without a filter capacitor. This curve is generated from the discharge cycles shown in Figure 3, but with offsets in the ACR data removed so they are equal at the start of each discharge. Doing so allows us to display the ACR delta between GSM and CC discharges, while zeroing out offsets from previous cycles.

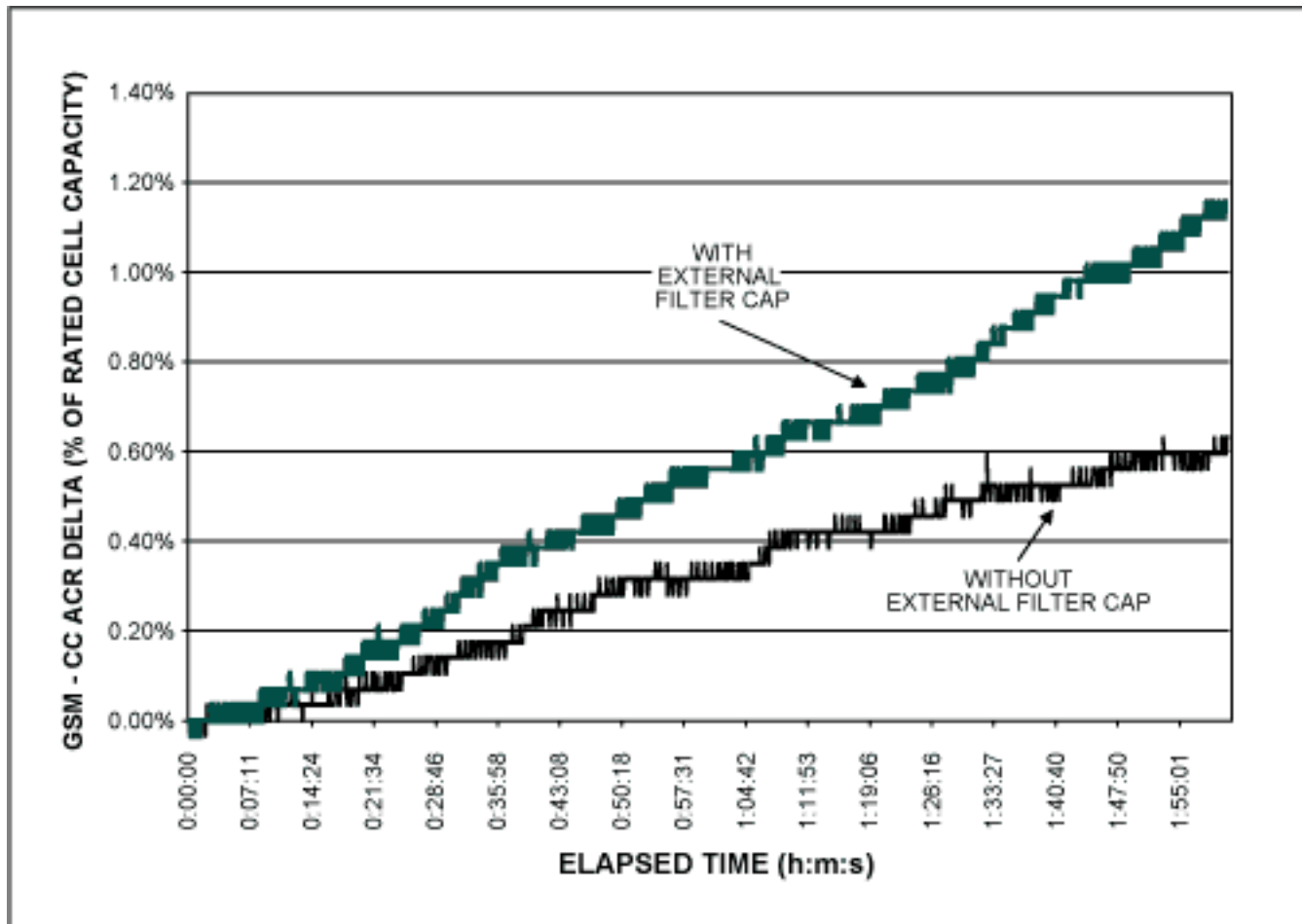

Figure 4. The difference in measured ACR between one GSM and one constant current discharge illustrates the deviation at the endpoints.

Consistent with the endpoint data, the presence of the filter cap does not offer a benefit, but appears to degrade performance under the GSM load. Although the prefilter integrates energy at high frequencies and reduces the sample rate requirements, its main purpose is to expand the dynamic range of the ADC under a pulsed load. A 1.6A pulse at 12% duty cycle (750mA filtered peak from Figure 1) does not exceed the 1.8A dynamic range limit of the DS2761, and thus the filter offers no benefit. In applications with higher current or larger duty cycles where the unfiltered signal may saturate the ADC, the benefit of the prefilter becomes more evident.

Conclusion

At first glance, a discrete ADC sampling that samples near the frequency of interest may not appear applicable. There is a temptation to apply the Nyquist sampling criterion generally. However, this study reviewed the application requirements and the criteria required to apply undersampling techniques, and in particular those relevant for measuring a signal's average value. The concept of uncorrelated undersampling near the signal frequency was shown qualitatively as an accurate method to capture DC content of a repetitive signal. Further, the frequency undersampling technique was quantitatively supported by measurements taken during charge and discharge (DC and pulse current) cycles using the DS2761 high-precision Li+ battery monitor. The data show that the deviation between the coulomb count under a DC discharge and a GSM load discharge is less than 1% of the rated cell capacity.

Application Note 1798: <http://www.maxim-ic.com/an1798>

More Information

For technical questions and support: <http://www.maxim-ic.com/support>

For samples: <http://www.maxim-ic.com/samples>

Other questions and comments: <http://www.maxim-ic.com/contact>

Related Parts

DS2761: [QuickView](#) -- [Full \(PDF\) Data Sheet](#)

AN1798, AN 1798, APP1798, Appnote1798, Appnote 1798

Copyright © by Maxim Integrated Products

Additional legal notices: <http://www.maxim-ic.com/legal>