

APPLICATION NOTE 1792

Self-Oscillating Contactor Driver Minimizes Hold Power

Abstract: This contactor circuit self-oscillates to minimize power consumption when on. The comparator switches as necessary to ramp the coil current up and down between the hysteresis limits. The circuit starts to self-oscillate as you increase the supply voltage.

For switching currents greater than about 25A, solenoid-operated switches called contactors are used in place of relays. A common application for contactors is in disconnecting the battery from a standby inverter or other high-power battery-operated system.

The **Figure 1** circuit acts as a self-oscillating step-down converter that saves power by periodically disconnecting the power supply. A high-speed, rail-to-rail comparator (IC1) acts as the control element. The contactor has a 12V coil and operates from a power supply of 10V to 28V, which (for example) allows use of the 12V or 24V obtained from one or two lead-acid automotive batteries. The circuit shown is compatible with an Allbright 2180-40B contactor, whose 14Ω winding draws a nominal 860mA and dissipates 10W. As described later, R1 can be changed to accommodate other coil ratings.

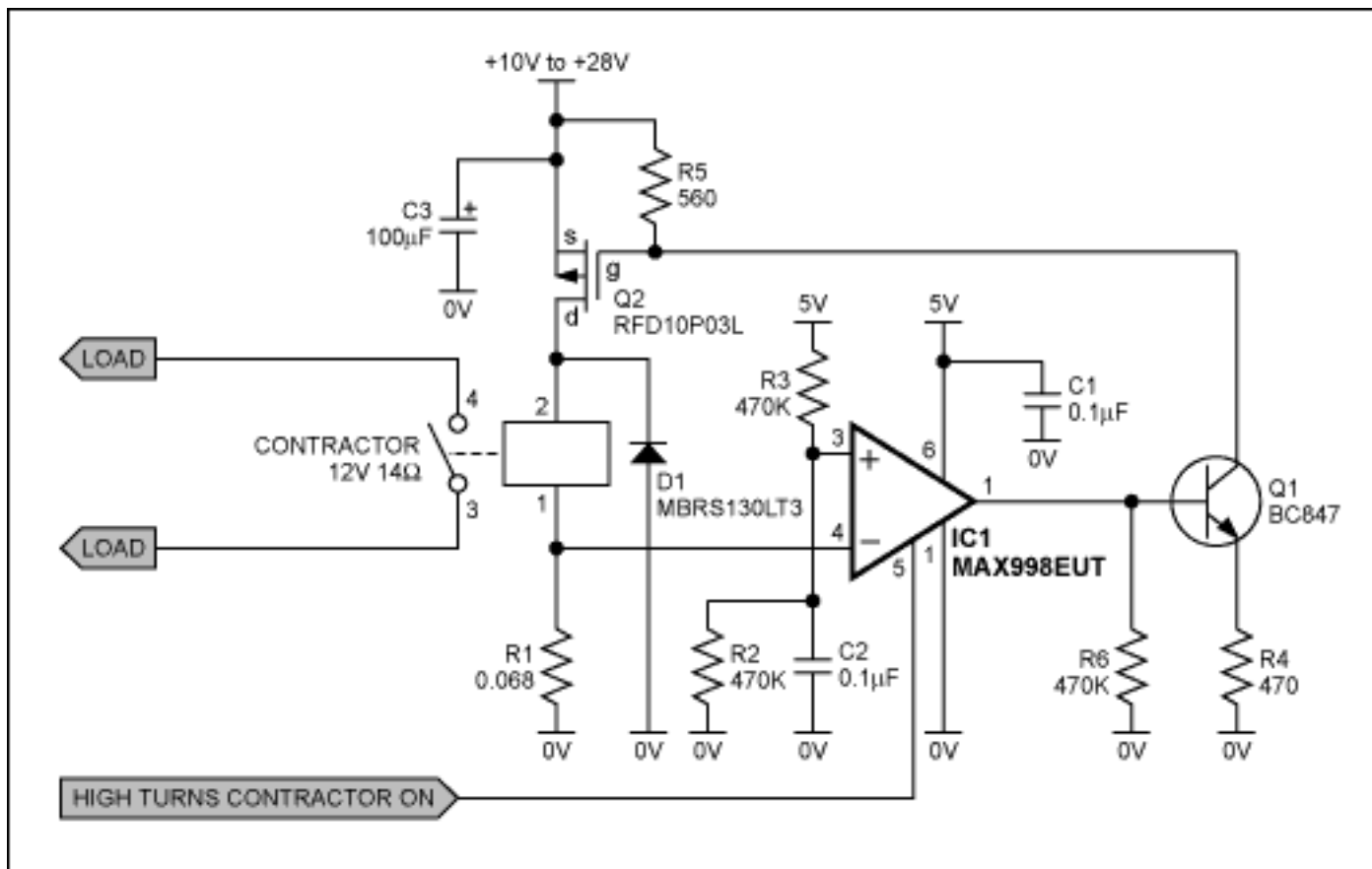

Figure 1. This contactor circuit self-oscillates to minimize power consumption when on.

When the comparator output is high, Q1 and Q2 are on and the contactor's coil current is rising. (Q1's common-base configuration provides a constant-current sink of about 9.5mA, which turns on Q2 by producing approximately 5.1V across R5.) Voltage in the current-sense resistor R1 rises until it reaches the 50mV level set by R3 and R2, causing a high-to-low transition (5V to 0V) at the comparator output. The coil current peaks at

$50\text{mV}/68\text{m}\Omega = 735\text{mA}$ when this trip occurs.

The rising coil current has a rate of $\Delta i = V_s \Delta t / L$, where V_s is the supply voltage and L is the coil inductance. When the R1 voltage reaches 50mV, Q1 and Q2 turn off and the coil current declines. Low-valued resistors in the Q1/Q2 configuration enable Q2 to turn off quickly, and the comparator's hysteresis (about 1.5mV) keeps Q1/Q2 off until the R1 voltage declines somewhat below 50mV. Off time is dominated by an approximate 5ms time constant formed by R5 and the gate-source capacitance of Q2. D1 and R1 provide a path for coilcurrent during the off interval, when it falls at a rate of $\Delta i = V_D \Delta t / L$. V_D is defined by D1's forward voltage.

The comparator switches as necessary to ramp the coil current up and down between the hysteresis limits, and the coil's fractional ripple current is defined as hysteresis/(trip voltage) = $1.5\text{mV}/50\text{mV} = 0.03$. Q2 remains on when supply voltage is too low to reach the current limit (10.3V in this case), so operation is assured down to the contactor's minimum pull-in voltage. The circuit starts to self-oscillate as you increase the supply voltage from 10.3V. Oscillation frequency increases with a decreasing duty cycle: off-time is fixed at $5\mu\text{s}$, and on-time must decrease because higher supply voltage ramps the coil current more steeply. As shown, the maximum frequency for a 28V supply is about 9.5kHz.

The circuit is easily modified to accommodate higher supply voltage and different contactors. The components shown, for instance, determine a 28V maximum set by the 30V limit specified for D1 and Q2. R1 can be adjusted for contactor coils with different current and voltage ratings. If you also adjust R4 and the R2/R3 divider, the 5V supply can be lowered as far as 2.7V. IC1 comes in a 6-pin SOT23 package, making the circuit small enough to fit on a small board attached to the contactor terminals. IC1's shutdown pin takes the output open circuit, and R6 ensures that Q1 remains off for that condition.

A similar version of this article appeared in the September 1998 issue of *CIE* magazine.

Application Note 1792: <http://www.maxim-ic.com/an1792>

More Information

For technical questions and support: <http://www.maxim-ic.com/support>

For samples: <http://www.maxim-ic.com/samples>

Other questions and comments: <http://www.maxim-ic.com/contact>

Related Parts

MAX998: [QuickView](#) -- [Full \(PDF\) Data Sheet](#) -- [Free Samples](#)

AN1792, AN 1792, APP1792, Appnote1792, Appnote 1792

Copyright © by Maxim Integrated Products

Additional legal notices: <http://www.maxim-ic.com/legal>