

APPLICATION NOTE 1781

Graphics Chip Supply Delivers 1.65V at 26A

Abstract: Game boxes are using more powerful processors to provide more realistic and complex graphics and games. As the processor power increases, so does the current required to power the parts. The MAX1954 in the application pictured below delivers 1.65V at 26A from a 5V input.

The MAX1954 is a 300kHz current-mode step-down controller. The MOSFET drivers are strong enough to handle 100nC gate charge. Given the nominal input and output voltages, the duty cycle is 33% and the on-resistance of the high- and low-side FETs are skewed accordingly. Two IRF7811W with 12m Ω on-resistance each are used for the high-side and two IRF7822 with 6.5m Ω on-resistance each are used for the low-side. Two IRF7811W in parallel have better switching characteristics than one IRF7822.

Seven 22 μ F/6V X5R ceramic capacitors are used for input bypassing to handle the 12.5A_{RMS} input ripple current. At 5V input, ceramic capacitors are more cost effective and smaller than electrolytics. In addition, the MAX1954 senses current by looking at the voltage across the high-side FET on-resistance and ceramic bypass capacitors provide a better reference for the current-sense circuitry. A 2.2nF ceramic capacitor is included drain-to-source across each low-side FET to damp the parasitic ringing of the bond-wire inductance with the drain capacitance. This ringing can affect the current-sense circuitry.

The pulse engineering inductor is a custom part designed to handle 70A peak current without saturating. The MAX1954 uses a "valley" current limit based on the on-resistance of the low-side FET. The current limit is 200mV divided by the low-side FET on-resistance (3.3m Ω) plus the inductor ramp current (10A) which equals 70A. A 0.5 μ H/70A inductor is not readily available and a custom design is required to provide short-circuit protection.

The Sanyo output capacitors provide a good balance among ESR, ripple current rating, and cost. The capacitance is large enough for the output ripple to be dominated by the ESR. The application does not require low-profile.

The catch-diode, D2, limits the negative voltage of the LX node when the high-side FET turns off. In conjunction with R4, this controls the voltage on the boost capacitor, C8, at high-line and maximum output current. Without D2 and R4, the voltage on C8 can BST to LX absolute maximum voltage of 6V.

The MAX1954 delivers 1.65V at 26A from a 5V input. The efficiency is 86% at 26A and 90% at 10A. The output ripple is 25mV_{p-p}.

Table 1.

V _{IN}	I _{IN}	V _{OUT}	I _{OUT}	Efficiency
5.0081	0.086	1.6663	0	
4.4905	11.13	1.6547	26	0.861
5.0125	9.95	1.6530	26	0.862
5.509	9.04	1.6513	26	0.862
		25mV _{p-p}		

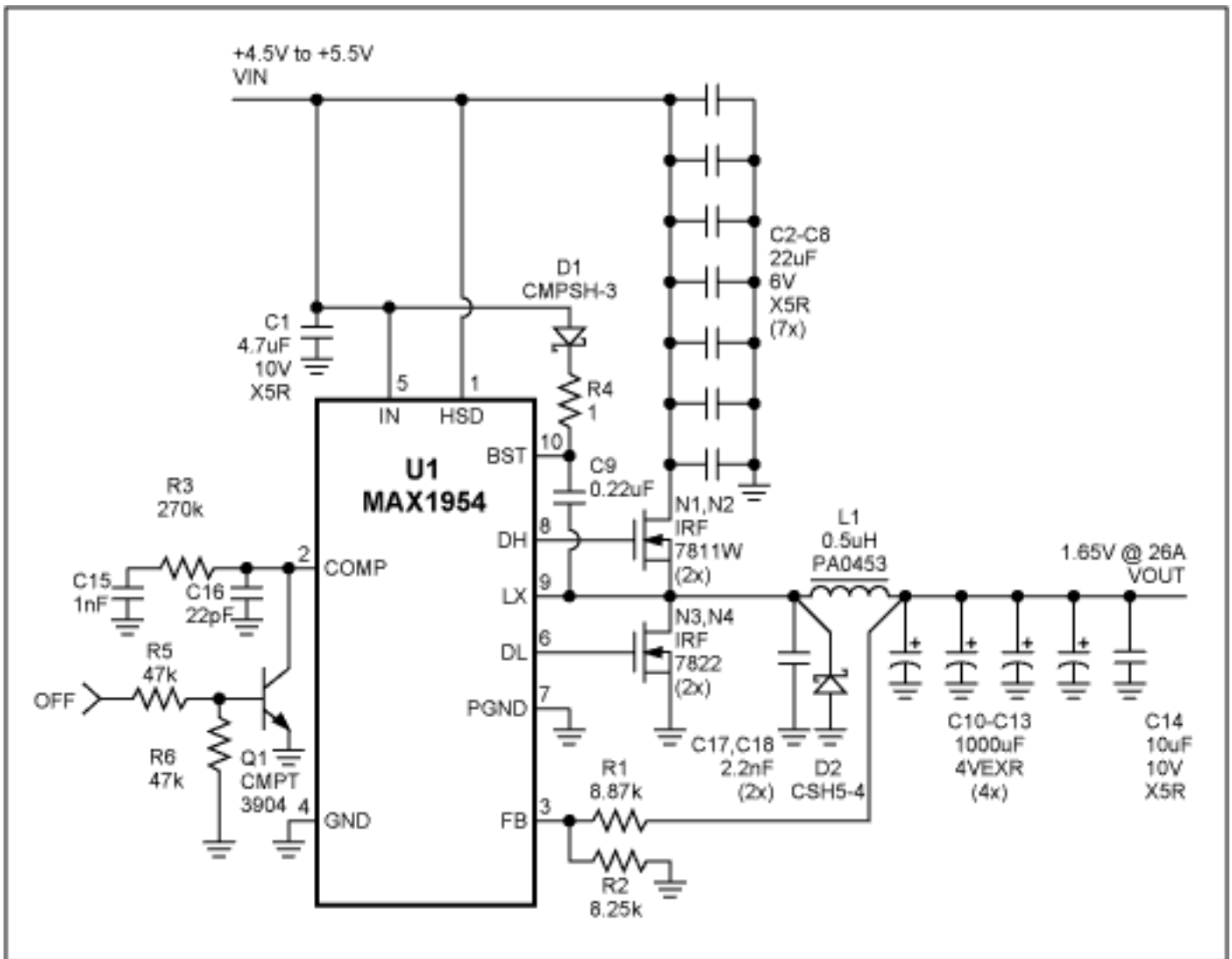

Figure 1.

The MAX1954 Bill of Materials: 4.5V to 5.5V Input, 1.65V at 26A Output

Designation	Qty	Description
C1	1	4.7 μ F 10V X5R ceramic capacitor (1206) Taiyo Yuden LMK316BJ475ML
C2-C8	7	22 μ F 6V X5R ceramic capacitor (1210) Taiyo Yuden JMK325BJ226MN
C9	1	0.22 μ F ceramic capacitor (0603)
C10-C13	4	1000 μ F 4V aluminum electrolytic capacitor Sanyo 4MV1000EXR
C14	1	10 μ F 10V X5R ceramic capacitor (1210) Taiyo Yuden LMK325BJ106MN
C15	1	1nF ceramic capacitor (0603) Kemet C0603C102K8RAC
C16	1	100pF ceramic capacitor (0603) Kemet C0603C101K5GAC
C17, C18	2	2.2nF ceramic capacitor (0603) Kemet C0603C222K8RAC
D1	1	100mA 30V Schottky diode Central Semi CMPSH-3
L1	1	0.5 μ H 30A Inductor Pulse Engineering PA0453
N1, N2	2	12m Ω 30V N-ch MOSFET (SO-8) International Rectifier IRF7811W
N3, N4	2	6.5m Ω 30V N-ch MOSFET (SO-8) International Rectifier IRF7822 or Siliconix Si4842DY
Q1	1	NPN Transistor (SOT-23) Central Semi CMPT3904
R1	1	8.87k Ω 1% resistor (0603)
R2	1	8.25k Ω 1% resistor (0603)
R3	1	270k Ω 5% resistor (0603)
R4	1	1 Ω 5% resistor (0603)
R5, R6	2	47k Ω 5% resistor (0603)
U1	1	MAX1954EUB (10- μ MAX [®])

μ MAX is a registered trademark of Maxim Integrated Products, Inc.

Application Note 1781: www.maxim-ic.com/an1781

More Information

For technical questions and support: www.maxim-ic.com/support

For samples: www.maxim-ic.com/samples

Other questions and comments: www.maxim-ic.com/contact

Keep Me Informed

Preview new application notes in your areas of interest as soon as they are published. Subscribe to [EE-Mail - Application Notes](#) for weekly updates.

Related Parts

MAX1954: [QuickView](#) -- [Full \(PDF\) Data Sheet](#) -- [Free Samples](#)

AN1781, AN 1781, APP1781, Appnote1781, Appnote 1781

