

APPLICATION NOTE 1753

A Simple Thermistor Interface to an ADC

Abstract: This article describes a simple and cost effective method of measuring temperature using a thermistor connected in a half-bridge configuration. The goal is to perform a ratiometric measurement such that the V_{REF} source voltage to the divider is the same as the reference to the analog-to-digital converter (ADC) used to measure the voltage at V_T .

There are many circuits and measurement methods that can be used with a thermistor to determine the temperature. The simplest approach is to use a half-bridge circuit also known as a resistor divider, shown in **Figure 1**. The goal is to perform a ratiometric measurement such that the V_{REF} source voltage to the divider is the same as the reference to the ADC used to measure the voltage at V_T . The R_1 resistance is known.

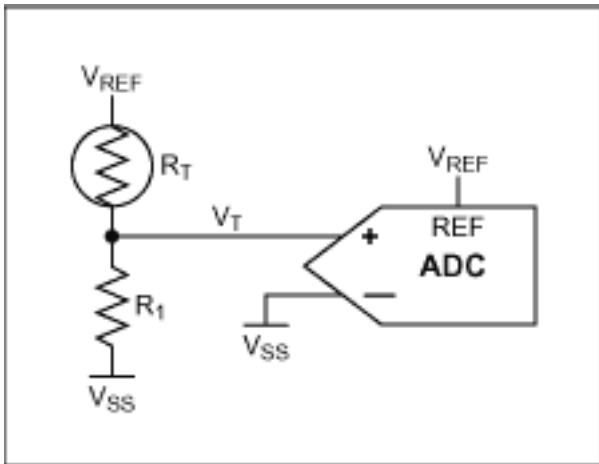

Figure 1.

The equation for V_T is shown in **Equation 1**.

$$V_T = \frac{R_1}{R_1 + R_T} \cdot V_{REF} \quad \text{Eq. 01}$$

The equation for the ADC result is shown in **Equation 2**.

$$\text{ADC} = \frac{V_T}{V_{REF}} \cdot 2^N \quad \text{Eq. 02}$$

where ADC is the ADC result and N = the ADC resolution.

Substituting Equation 1 into Equation 2 yields **Equation 3** and the V_{REF} term is cancelled out. This leaves the R_1 value, which is known, and the ADC result, which is measured. The R_1 resistor should be a temperature stable resistor otherwise it will affect the accuracy of the temperature measurement.

$$ADC = \frac{R_1}{R_1 + R_T} \cdot 2^N \quad \text{Eq. 03}$$

Rearranging Equation 3 and solving for R_T yields **Equation 4**.

$$R_T = \left(\frac{2^N}{ADC} - 1 \right) \cdot R_1 \quad \text{Eq. 04}$$

After the value for R_T is calculated, the temperature can then be calculated by using the equation provided by the thermistor vendor. An example of an equation is shown in **Equation 5**, which is for a NTC thermistor.

$$T(^{\circ}\text{C}) = [b_0 + b_1(\ln R_T) + b_3(\ln R_T)^3]^{-1} - 273.25 \quad \text{Eq. 05}$$

The thermistor vendor would provide the value for the coefficients b_0 , b_1 , and b_3 . The equation can be solved for directly or a lookup table can be used if easier. Simple linear interpolation between the table data points is required to gain the proper resolution. A plot of the NTC thermistor is shown below in **Figure 2**.

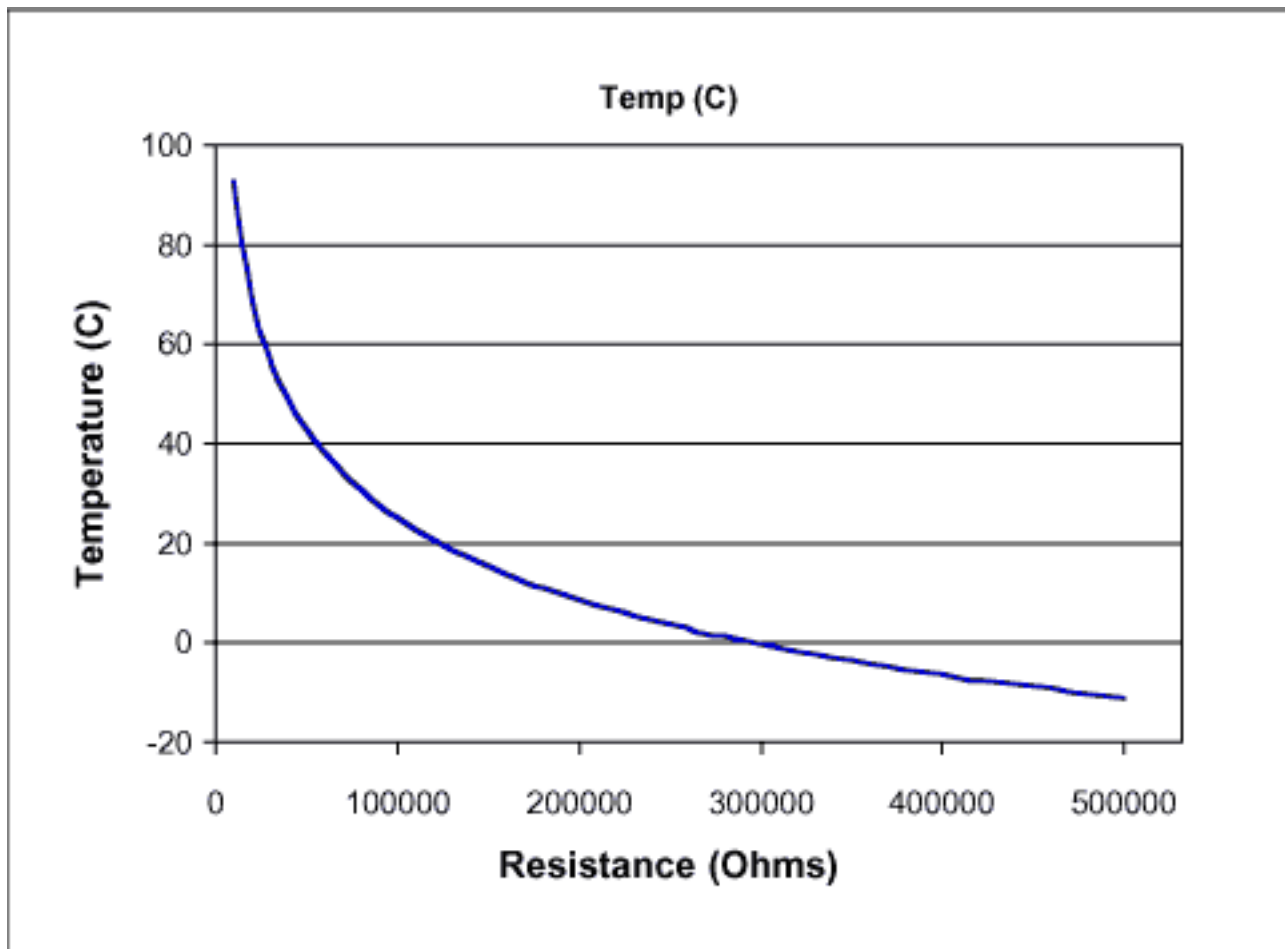

Figure 2.

Application Note 1753: <http://www.maxim-ic.com/an1753>

More Information

For technical questions and support: <http://www.maxim-ic.com/support>

For samples: <http://www.maxim-ic.com/samples>

Other questions and comments: <http://www.maxim-ic.com/contact>

AN1753, AN 1753, APP1753, Appnote1753, Appnote 1753

Copyright © by Maxim Integrated Products

Additional legal notices: <http://www.maxim-ic.com/legal>