

APPLICATION NOTE 175

LAN Power Supply Generates Isolated 9V

This low-power, isolated 9V supply for LAN applications (**Figure 1**) delivers more than 250mA (more than 2W of output power). For inputs of 10.8V to 13.2V combined with load currents of 1mA to 200mA, the nominal 8.78V output provides about $\pm 1\%$ of line and load regulation.

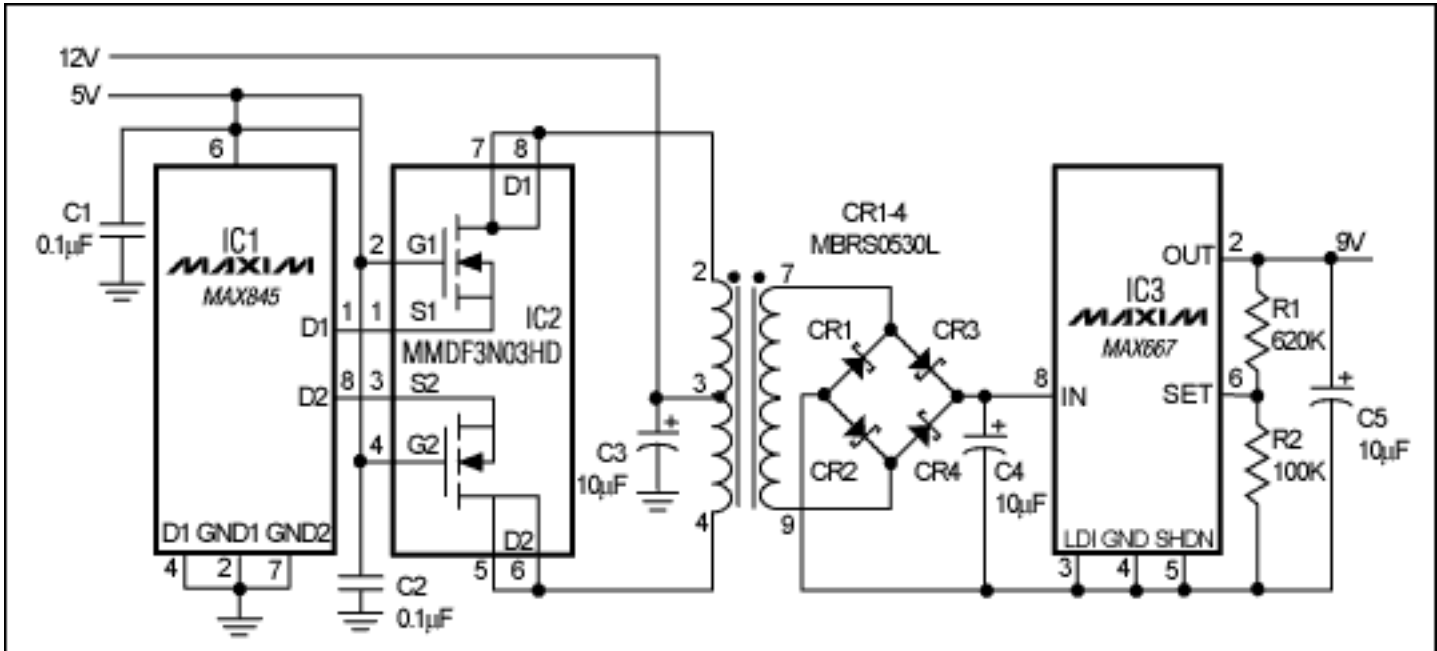

Figure 1. This regulator circuit provides an isolated 9V at 250mA for local area network (LAN) applications.

IC1's transformer-driver outputs (D1 and D2) normally drive each end of the primary directly—a configuration in which each driver terminal (on turnoff) sees a flyback voltage equal to twice the center-tap voltage. The flyback in this application (24V) exceeds the maximum rating for IC1 (12V), so two MOSFETs in cascode have been introduced to stand off the extra voltage while maintaining IC1's high switching frequency (typically 650kHz).

Surface-mount transformer T1 has a split primary, a single secondary, and a turns ratio of 1:1:1. This single-secondary approach requires fullwave-bridge rectification and a two-diode-drop reduction in output voltage, but the alternative—a split secondary, halfwave rectification at each end, and a one-diode drop in output voltage—adds an extra winding that increases the transformer cost.

The single-winding primary inductance should be high (about 250µH) to limit stored-energy losses. (The ideal is an infinite inductance, which would enable pure transformer action with no energy loss during the switching cycles.) The diode bridge is followed by a low-dropout linear regulator (IC3), which provides the 9V regulated output for inputs of 5V and 12V $\pm 10\%$.

A similar idea appeared in the 4/11/96 issue of EDN.

Application Note 175: <http://www.maxim-ic.com/an175>

More Information

For technical questions and support: <http://www.maxim-ic.com/support>

For samples: <http://www.maxim-ic.com/samples>

Other questions and comments: <http://www.maxim-ic.com/contact>

Related Parts

MAX667: [QuickView](#) -- [Full \(PDF\) Data Sheet](#) -- [Free Samples](#)

MAX845: [QuickView](#) -- [Full \(PDF\) Data Sheet](#) -- [Free Samples](#)

AN175, AN 175, APP175, Appnote175, Appnote 175

Copyright © by Maxim Integrated Products

Additional legal notices: <http://www.maxim-ic.com/legal>