



APPLICATION NOTE 1737

MAX2510 I/Q Modulator Performance In The Presence of DC Offset Voltages

Abstract: RF systems which require direct coupling between the baseband output DAC and the input to the I/Q modulator present a design challenge. This unique requirement of direct coupling does not exist in many RF systems because the modulation and encoding are contrived to avoid the need for DC response at this point in the system. When the need for very low frequency response exists, a way must be found to route the DAC output signal into the I/Q modulator while providing acceptable RF performance. This application note describes tests carried out on the MAX2510 IF transceiver to measure the impact of DC coupling into the modulator, presents the test results, and proposes a simple circuit to provide the DC interface to the MAX5183 DAC.

Additional Information:

- [Wireless Product Line Page](#)
- [Quick View Data Sheet for the MAX2510](#)
- [Quick View Data Sheet for the MAX5183](#)
- [Applications Technical Support](#)

Introduction

RF systems which require direct coupling between the baseband output DAC (digital to analog converter) and the input to the I/Q (in-phase/quadrature) modulator present a design challenge. This unique requirement of direct coupling does not exist in many RF systems because the modulation and encoding are contrived to avoid the need for DC response at this point in the system. When the need for very low frequency response exists, a way must be found to route the DAC output signal into the I/Q modulator while providing acceptable RF performance. This application note describes tests carried out on the MAX2510 IF transceiver to measure the impact of DC coupling into the modulator, presents the test results, and proposes a simple circuit to provide the DC interface to the MAX5183 DAC.

The results showed that in the presence of 10mV of offset on one modulator input, the LO (local oscillator) suppression is degraded from -43dBc to -20dBc. Offset voltages of ± 20 mV on both I and Q inputs degrades the LO suppression to -15dBc. Test were conducted with the LO at 200MHz.

Approach

The impact of offset voltage on the RF performance of the I/Q modulator in the MAX2510 needs to be understood before an interface can be designed. To assess this impact, the MAX2510 evaluation kit was modified to allow varying of the offset voltages (see **Figure 1**), while the I/Q modulator output was observed on a spectrum analyzer.

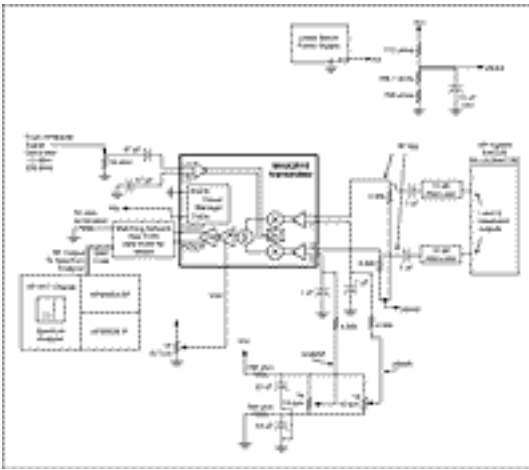

[For Larger Image](#)

Figure 1. MAX2510 modulator offset voltage test setup.

The standard MAX2510 evaluation kit is modified by adding three 10-turn potentiometers. One sets the gain control voltage for the output amplifier. The other two 10-turn potentiometers serve to impose an offset voltage on the I and Q inputs to the modulator. A signal generator is used to supply the 200MHz, -13dBm local oscillator. A signal generator with baseband quadrature outputs is used to drive the I and Q inputs of the modulator. 10dB attenuators reduce the I and Q signal level supplied to the MAX2510 to avoid distortion. The output spectrum is observed on the spectrum analyzer.

It was predicted that the main impact of offset voltage would be the LO suppression of the modulator. This was proven true in a few quick experiments where the output spectrum was observed while the offset voltage was varied. The sideband suppression showed very little change, and the same was true of the gain and second harmonic level.

Table 1 presents the actual data from laboratory measurements, showing the dependence of LO level on the offset voltage.

Test conditions for all data are:

- All tests at room temperature
- Type of modulation: CW
- $V_{CC} = 3.3V$
- $V_{BIAS} = 1.809V$
- $V_{GC} = 2.003V$
- LO = 200MHz, -13dBm

Table 1. MAX2510 I/Q modulator RF performance vs. offset voltage

	Q_{OFFSET} voltage (mV)	LO level (dBc)	I_{OFFSET} set for minimum (mV)	SA Ref. level	LO	VQ pp	V_{BIAS}	VGC
Vary just the Q_{OFFSET}	0	-43	2	-13dBm	200MHz, -13dBm	0.4V	1.809V	2.003V
	-4	-28	2					
	-9	-22	2					
	-19	-15	2					
	6	-22	2					
	11	-18	2					
	21	-13	2					
	I_{OFFSET} voltage (mV)	LO level (dBc)	Q_{OFFSET} set for minimum (mV)					
Vary the I_{OFFSET}	0	-44	-1					
	3	-33	-1					
	8	-23	-1					
	13	-18	-1					
	18	-15	-1					
	-7	-21	-1					
	-12	-18	-1					
	-22	-13	-1					
	Q_{OFFSET} voltage (mV)	I_{OFFSET} voltage (mV)	LO level (dBc)	Lower sideband (dBc)	2nd harmonic			
Vary both the I_{OFFSET} and Q_{OFFSET}	-3	2	-44	-40	-34dBc			
	-20	2	-20	-40				
	-20	20	-17	-40				
	20	20	-16	-40				
	20	-20	-15	-40	-32dBc			

Proposed Interface

Using the lab results, an interface can be proposed to connect the MAX5183 DAC to the MAX2510 modulator. **Figure 2** shows the interface design complete with the required low pass filter.

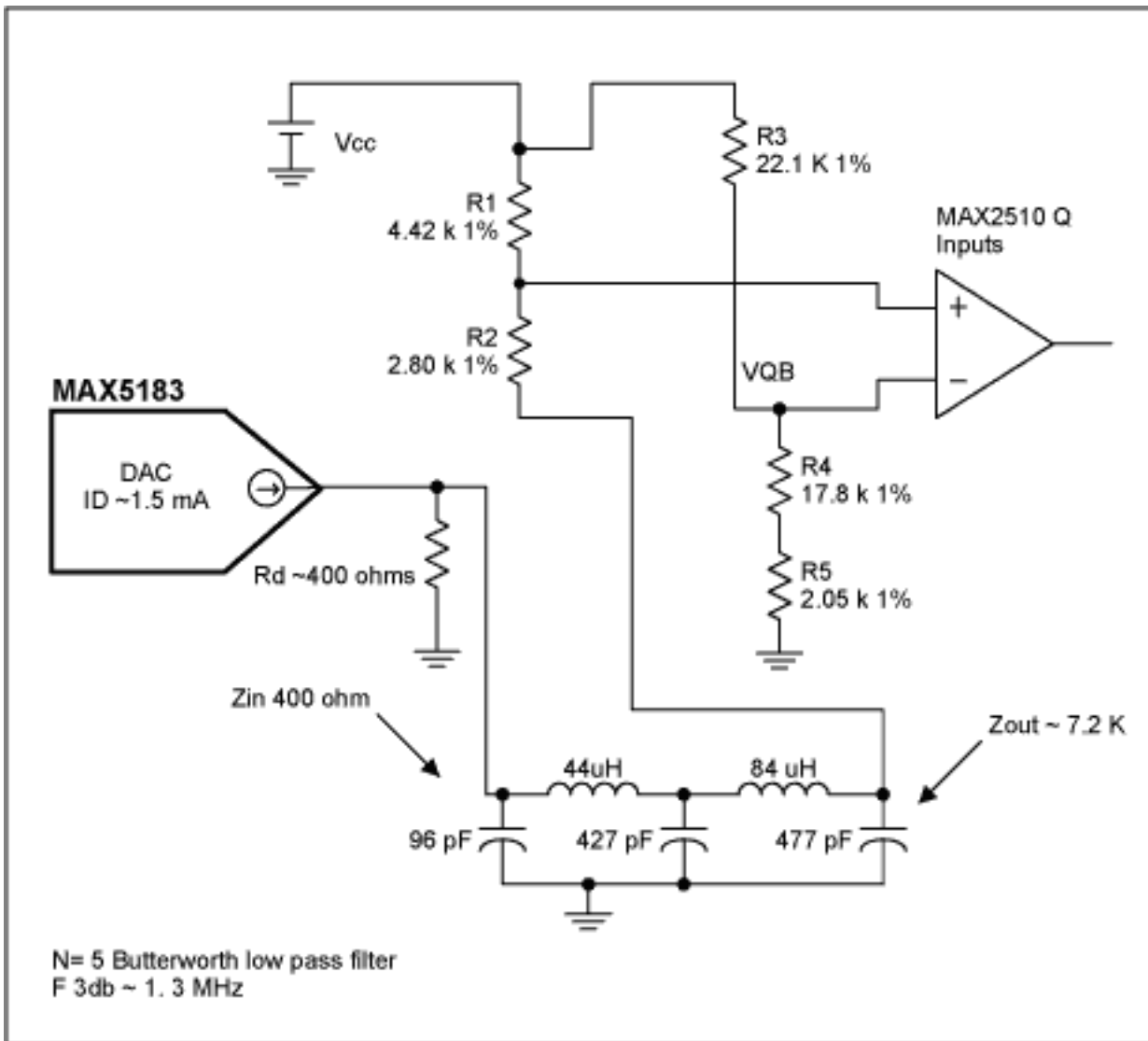

Figure 2. Interface design with Butterworth low pass filter.

The interface uses resistors to implement the needed level shifting. Some readers will object to the loss of this interface. This loss is acceptable because the signal amplitude from the MAX5183 DAC is larger than needed to drive the MAX2510 I/Q inputs. Another concern with this proposed interfaces is noise conducted from the power supply to the I and Q inputs. The use of differential networks causes any power supply noise to be presented to the inputs in common mode fashion. The common mode rejection of the modulator should help to reject this noise and keep the output spectrum clean.

Application Note 1737: www.maxim-ic.com/an1737

More Information

For technical questions and support: www.maxim-ic.com/support

For samples: www.maxim-ic.com/samples

Other questions and comments: www.maxim-ic.com/contact

Keep Me Informed

Preview new application notes in your areas of interest as soon as they are published. Subscribe to [EE-Mail - Application Notes](#) for weekly updates.

Related Parts

MAX2510: [QuickView](#) -- [Full \(PDF\) Data Sheet](#) -- [Free Samples](#)

MAX5183: [QuickView](#) -- [Full \(PDF\) Data Sheet](#) -- [Free Samples](#)

AN1737, AN 1737, APP1737, Appnote1737, Appnote 1737

Copyright © by Maxim Integrated Products

Additional legal notices: www.maxim-ic.com/legal