

## APPLICATION NOTE 1212

## Pulsed Sensor Extends Battery Life

**Abstract:** The following application note demonstrates a power saving circuit that pulses a sensor for 1 second every 30 minutes. Designed to monitor levels of salt crystals in a water softener the circuit consumes an average of 70µA.

Activating the sensor circuit in **Figure 1** for 1 second every 30 minutes reduces the circuit's 20mA supply current to an average of 70µA. For a battery consisting of three AA Duracells, this pulsed operation extends the battery life to several years.

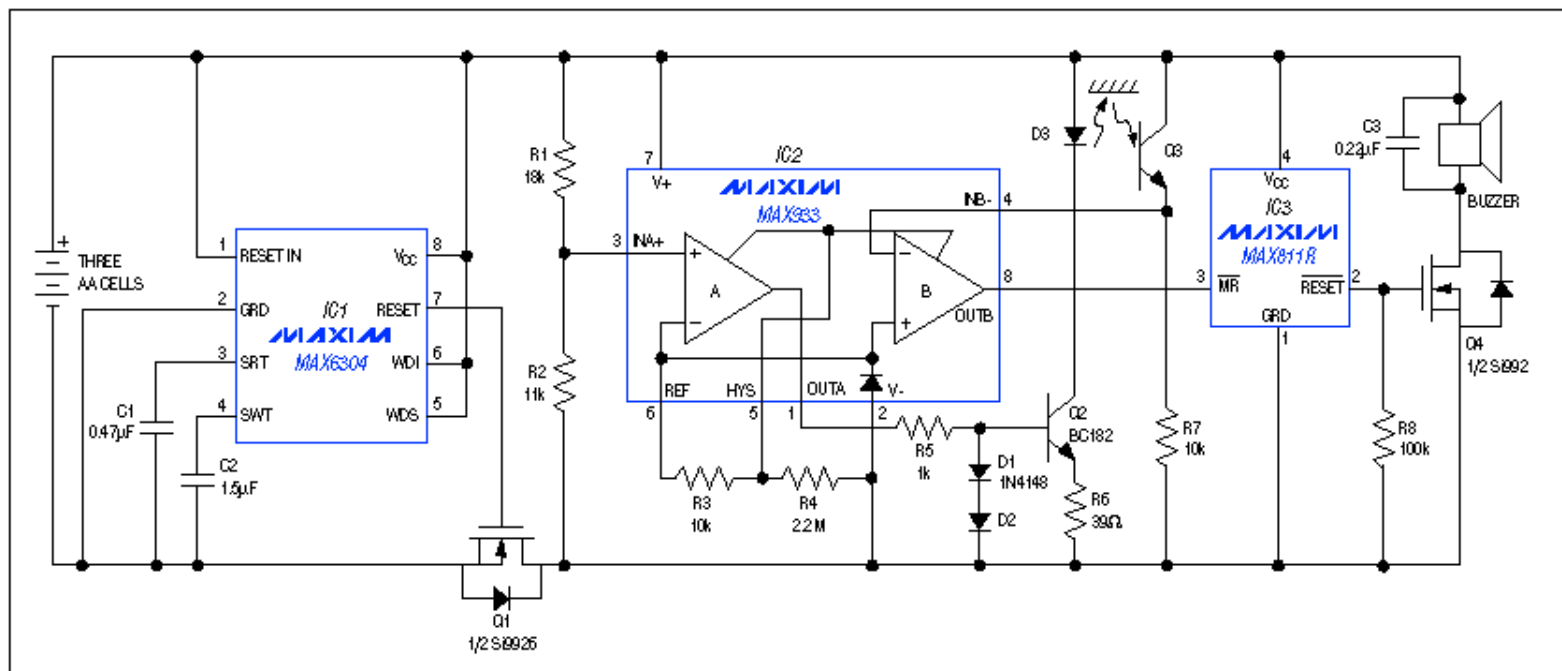

Figure 1. Powered by three AA cells, this optoelectronic sensor has a battery life of several years.

The sensor shown is an optocoupler with an infrared-emitting diode. Designed to monitor the level of salt crystals in a water softener, it relies on a reflection from the crystals to generate a "no-alarm" level of emitter current in the phototransistor (Q3). As the salt level drops past the sensor's position, this current level makes a step change downward.

When the drop across R7 equals the reference voltage in the comparator/reference device (IC2), comparator B's output goes high and releases the manual reset on the voltage monitor (IC3). After a minimum reset-delay interval of 140ms, Q4 turns on and sounds the buzzer. Comparator A monitors the battery voltage via R1 and R2: at levels above 3V, it activates the IR-emitting diode (D3) by turning on the constant-current sink consisting of Q2 and associated components. Thus, the buzzer sounds for 1 second every 30 minutes if the battery voltage is below 3V, or if the salt level is low.

Power for the sensor is available only when Q1 turns on. Q1 is controlled by IC1—a microprocessor supervisor configured as a time-base generator. (IC1 consumes less power and has a smaller footprint than the alternative 5556 timer or a 555 timer with multistage counters. It also eliminates the large capacitors otherwise required.) Connected directly across the battery, it draws 60µA at 4.5V and 40µA at 3.0V.

IC1's external connections cause its internal watch-dog timer to cycle repeatedly. With C2 = 1.5µF as shown, the internal timeout is 3.6 seconds, and connecting WDS high multiplies this value by 500, extending it to the desired 30 minutes. Each timeout produces a reset pulse that applies power to the remaining circuitry by turning on Q1 for an interval of 1 second (approximately). From the MAX6304 data sheet:

$$t_{\text{RESET}} = (2.67) (C1) \text{ (in } \mu\text{F)} = 1.25 \text{ seconds}$$

$$t_{\text{WATCHDOG}} = (2.67) (C2) \text{ (in } \mu\text{F)} (500) = 30 \text{ minutes.}$$

A similar idea appeared in the 1/1/98 issue of EDN.

Application Note 1212: <http://www.maxim-ic.com/an1212>

### More Information

For technical questions and support: <http://www.maxim-ic.com/support>

For samples: <http://www.maxim-ic.com/samples>

Other questions and comments: <http://www.maxim-ic.com/contact>

### Related Parts

MAX6304: [QuickView](#) -- [Full \(PDF\) Data Sheet](#) -- [Free Samples](#)

MAX811R: [QuickView](#) -- [Full \(PDF\) Data Sheet](#) -- [Free Samples](#)

MAX933: [QuickView](#) -- [Full \(PDF\) Data Sheet](#) -- [Free Samples](#)

