



## APPLICATION NOTE 1211

# WCDMA Superheterodyne Reference Design: V1.0 RF Transceiver Description

*Abstract: A complete WCDMA transceiver is described in detail. Operation is at 2140MHz for the receiver, and 1950MHz for the transmitter. The MAX2388 front end mixes down to a 190MHz IF. The MAX2309 converts the receiver IF to baseband, whilst supplying a 75dB gain control range. The MAX2363 uses a 320MHz transmit IF, supplies the I/Q modulation, and the RF upconversion function.*

The WCDMA superheterodyne RF transceiver is designed around four key ICs:

- The MAX2388 Receive Front End
- The MAX2309 IF Quadrature Demodulator
- The MAX2363 Quadrature Modulator/Upconverter Transmit IC

A PC-compatible applications software load that controls an interface PC board (by means of the parallel port) provides the baseband control for this design. The interface PC board plugs into the WCDMA Reference Design board, and also permits baseband I-Q signals to connect, so that the user has complete manual and keyboard static control of the transceiver design.

The chipset architecture is as follows: The RF receive band is 2110MHz to 2170MHz, whereas the RF transmit band is 1920MHz to 1980MHz, and a duplexer filter connects each path to the antenna for full duplex operation. A common RF LO is used for the first conversion stages, and its synthesizer is built into the transmit IC. The receive IF is set to 190MHz, whereas the transmit IF is set to 380MHz, to serve the frequency-duplex spacing. Interface to the baseband processor is by means of analog I-Q signals.

## RF Front End

The MAX2388 combines a high-gain LNA with a low-current single-balanced mixer. The LNA provides 15dB of gain (0dB when switched to low-gain mode) with 2dB NF, and the mixer provides approximately 7dB of gain. With 3dB loss in the duplexer, and 2.5dB loss in the RF interstage filter at the LNA output, the net in-band front-end gain is approximately 18.5dB (high-gain mode), with a noise figure of approximately 5dB. A low-pass impedance match to the IF SAW filter is required at the mixer output to suppress the LO fundamental. The single-balanced mixer is employed, because it offers the lowest power dissipation for a given performance. Its required LO drive level is very low, at -10dBm. For more information, please see [MAX2388 at 190MHz IF for WCDMA](#).

## IF Demodulator

The MAX2309 provides the IF amplifier, IF LO synthesizer, and quadrature demodulation functions for the receive path. Its IF variable-gain amplifier offers between -35dB and +40dB of signal-path gain measured at the I and Q baseband outputs. The on-chip PLL and VCO provide the fixed second LO. Because the quadrature demodulator uses a divide-by-two in the LO path, the VCO fundamental is set to twice IF, at 380MHz.

The baseband interface is by means of differential, DC-coupled I and Q signals. The receive amplitude is held constant by the AGC function over a 75dB signal-level range. The minimum signal level at rated sensitivity is

estimated to be 10mV. Transmit amplitude is set at 600mV or 900mVpp, depending on its software setting. For more information, please see [MAX2309/MAX2312 at 190MHz IF for WCDMA](#).

## Transmit Modulator

The MAX2363 is a transmitter IC that takes the baseband transmit I and Q differential input signals and performs quadrature modulation, IF and RF LO synthesis, and RF upconversion. The IF LO is synthesized by means of the on-chip VCO and PLL, which runs at 760MHz. This signal is divided by two internally to drive the quadrature modulator. The output level of the quadrature modulator is set by a 3-bit "IF DAC" and also the global on-chip analog Vgc signal, which sets both RF and IF signal levels in tandem with one pin.

## RF Transmit and LO

The MAX2363 also contains the RF PLL, using an off-chip VCO module. The RF LO is set for high-side injection and generates approximately -10dBm into the MAX2388 receive mixer and -7dBm into the MAX2363 transmit upconverter mixer. The upconverter output drivers can provide up to +8dBm in the WCDMA band of 1920MHz to 1980MHz, and the output level can be controlled over a 58dB range, while maintaining specified signal purity. In order to meet the requirement for a 75dB transmit power control range, an external, variable, pin-diode attenuator is added before the power-amplifier input RF filter.

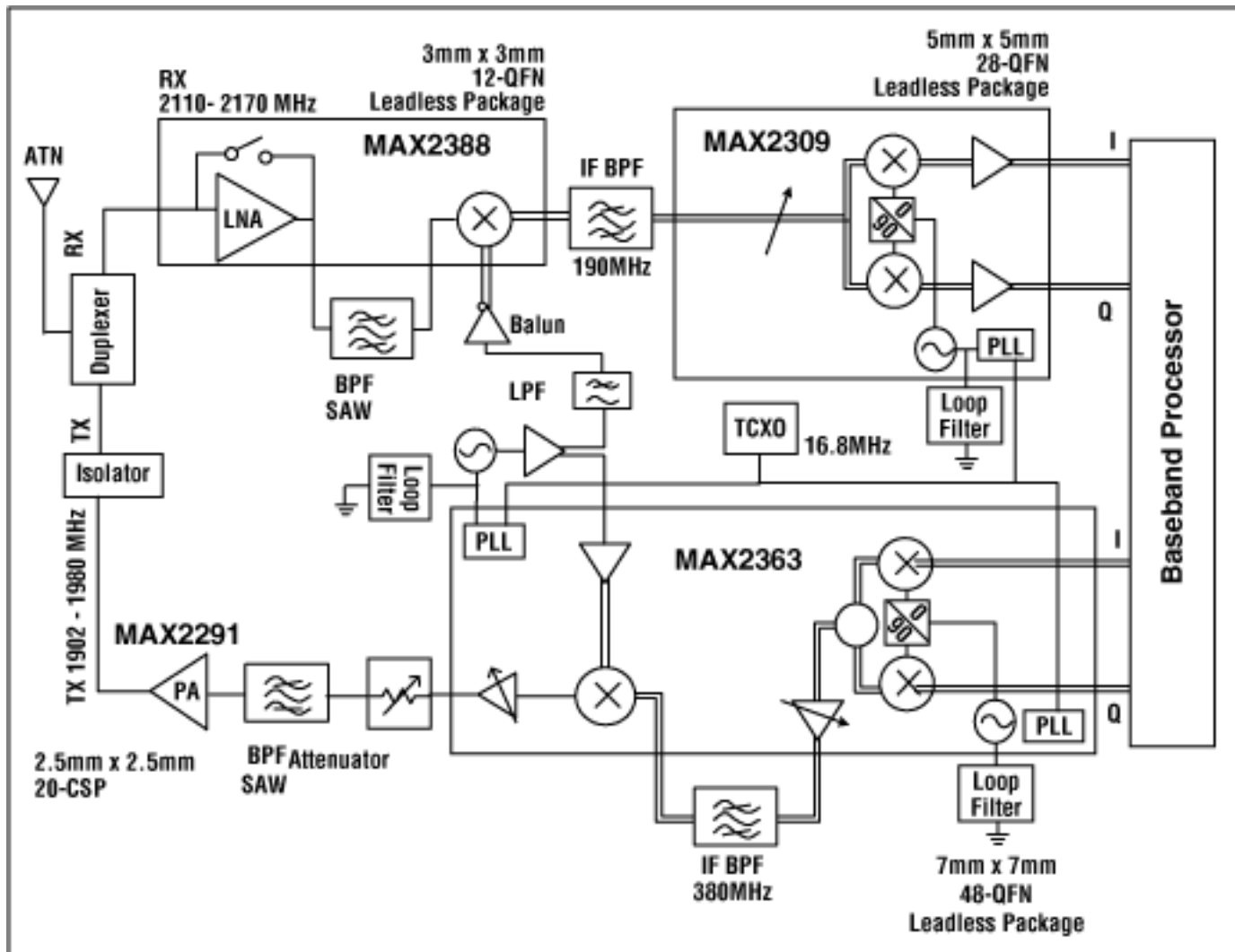

Block diagram of a WCDMA system

Application note 1211: [www.maxim-ic.com/an1211](http://www.maxim-ic.com/an1211)

### More Information

For technical support: [www.maxim-ic.com/support](http://www.maxim-ic.com/support)

For samples: [www.maxim-ic.com/samples](http://www.maxim-ic.com/samples)

Other questions and comments: [www.maxim-ic.com/contact](http://www.maxim-ic.com/contact)

---

### Automatic Updates

Would you like to be automatically notified when new application notes are published in your areas of interest?

[Sign up for EE-Mail™](#).

---

### Related Parts

MAX2309: [QuickView](#) -- [Full \(PDF\) Data Sheet](#) -- [Free Samples](#)

MAX2363: [QuickView](#) -- [Full \(PDF\) Data Sheet](#) -- [Free Samples](#)

MAX2388: [QuickView](#) -- [Full \(PDF\) Data Sheet](#) -- [Free Samples](#)

AN1211, AN 1211, APP1211, Appnote1211, Appnote 1211

Copyright © by Maxim Integrated Products

Additional legal notices: [www.maxim-ic.com/legal](http://www.maxim-ic.com/legal)