



Keywords: microprocessor reset generator, ultra-low power, relaxation oscillator, long battery life, pulse generator

Sep 06, 2002

APPLICATION NOTE 1186

Ultra Low Power Reset Generator

Abstract: This application note describes an ultra-low power microprocessor reset generator that is capable of operating for decades from a single AA Lithium cell. Where continuous intermittent reset is desired, this relaxation-oscillator circuit can provide adjustable pulse width and reset period. Typical operation producing 100 μ s pulses each second requires only 1 μ A current from a 1.8-5.5V supply. Formulas are provided for calculation of component values for a wide range of pulse width and period.

When a processor-controlled device must be guaranteed to operate, designers often choose to reset the processor periodically rather than rely on a watchdog circuit. In low-power systems the periodic reset generator can consume a large part of the system current budget or may not be guaranteed to operate at low voltages.

This application note describes a low-power reset generator that generates a low going reset pulse of 100 μ S duration once per second, consumes less than 1 μ A and will operate from 1.8V to 5V with only slight variation of the output period.

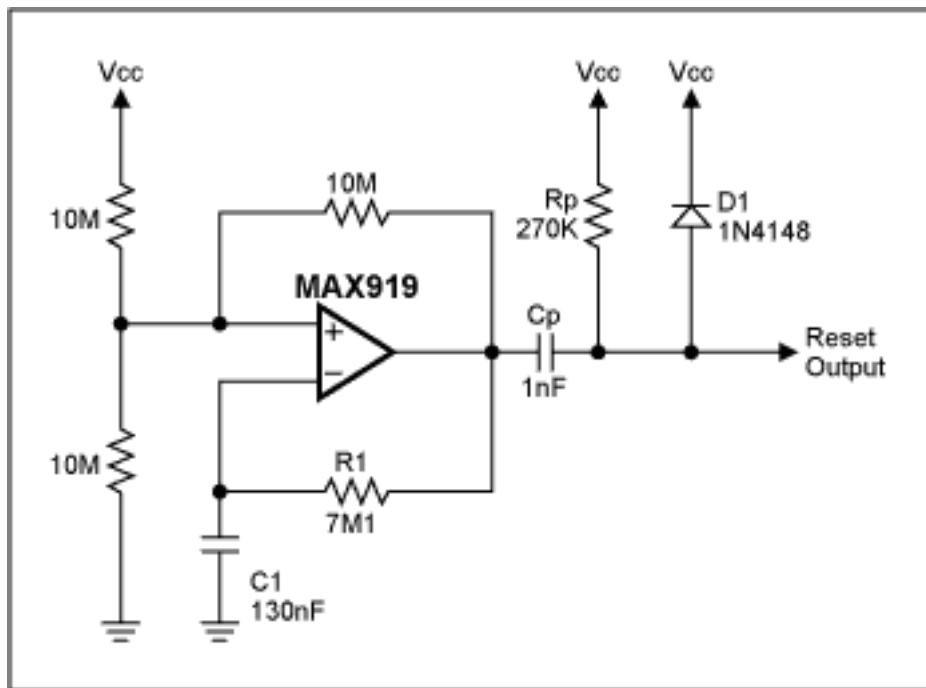

Figure 1. This reset circuit consumes less than 1 μ A and delivers a 100- μ sec-wide reset pulse every 1.3 sec.

The circuit is an adaptation of a normal relaxation oscillator with a differentiator and diode clamp on the output to generate the 100 μ S low going pulse. The pulse width can be adjusted by varying C_p or R_p and the polarity changed by repositioning D_1 . The period can be adjusted by varying R_1 or C_1 .

The 350nA supply current, 1.8V-5.5V supply voltage range and SOT23 package make the MAX919 ideal for this application. Measurements for the complete circuit give operating currents of less than 1 μ A at 25 $^{\circ}$ C, which would allow the circuit to operate from a single AA lithium cell for 250 years!

With careful component choice this circuit is able to generate periods from mS to minutes. To ensure good

temperature stability R1 and Rp should be metal film and C1 and Cp should be NPO type capacitors. Assuming a CMOS type input, high impedance and with a logic threshold of 30% of the supply rail, then the following formulas can be used to adjust the output pulse width and period:

$$\text{Pulse width} \cong 0.36 R_p C_p$$

$$\text{Period} \cong 1.4 R_1 C_1$$

Measured pulse width:

1.308 seconds @ 4.5V

1.306 seconds @ 1.8V

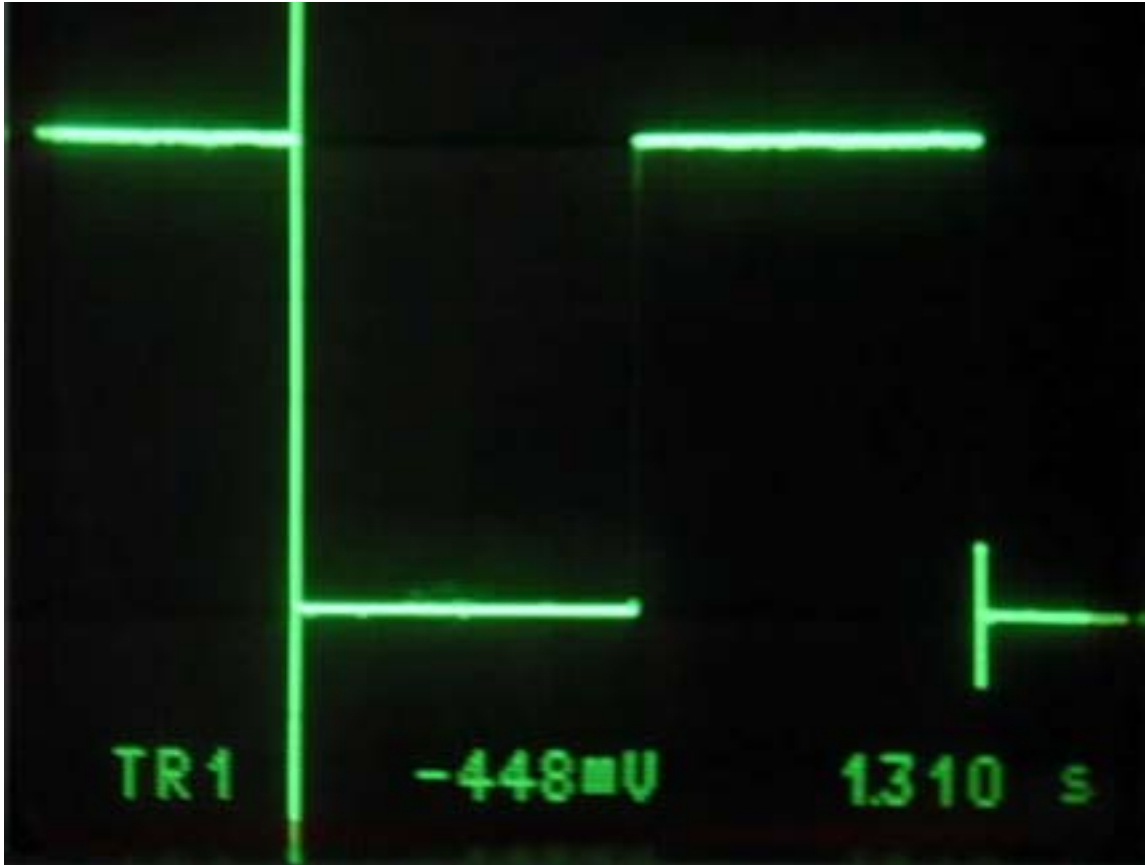

Figure 2. Comparator output; horizontal scale = 200mS/div, vertical scale = 1V/div, supply voltage = 4.5V, amplitude = 4.48Vp-p, period = 1.310 seconds.



Figure 3. Comparator output; horizontal scale = 200mS/div, vertical scale = 500mV/div, supply voltage = 1.7V, amplitude = 1.7Vp-p, period = 1.308 seconds.

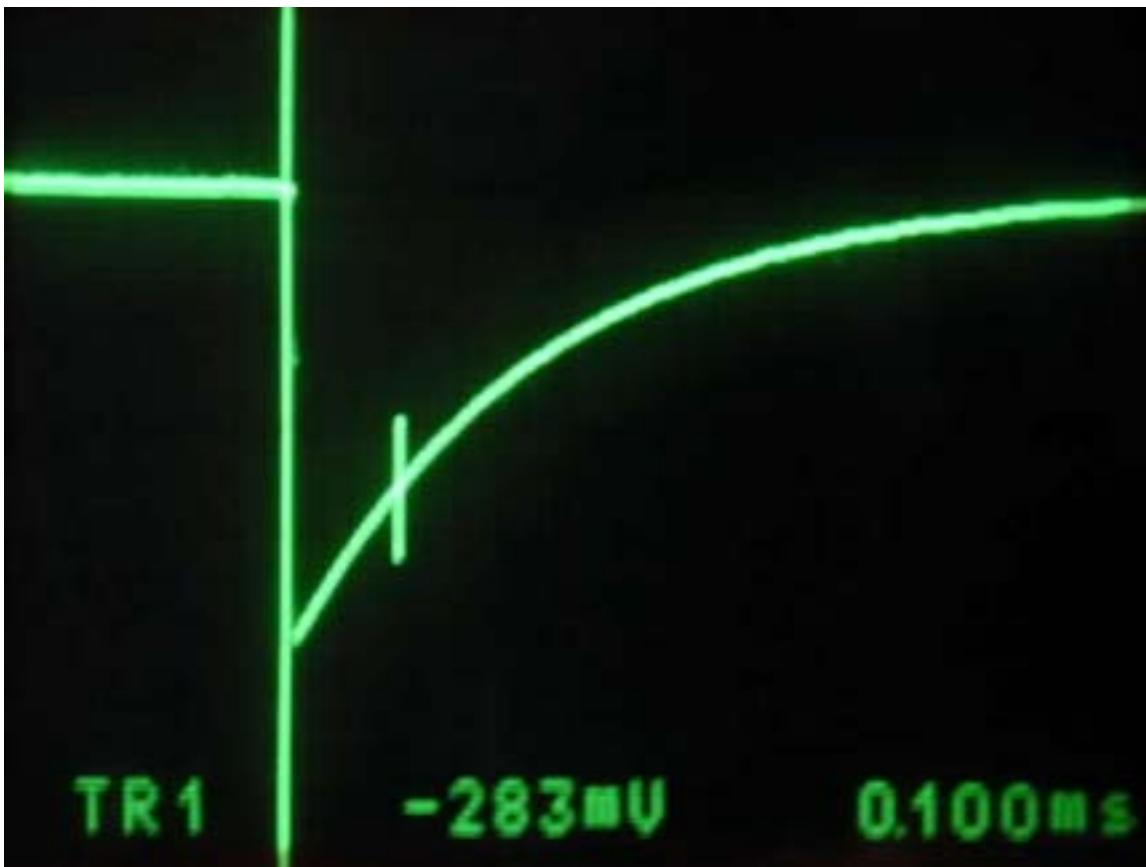

Figure 4. Pulse output; horizontal scale = 100 μ S/div, vertical scale = 1V/div, supply voltage = 4.5V, pulse width (30%) = 100 μ S.

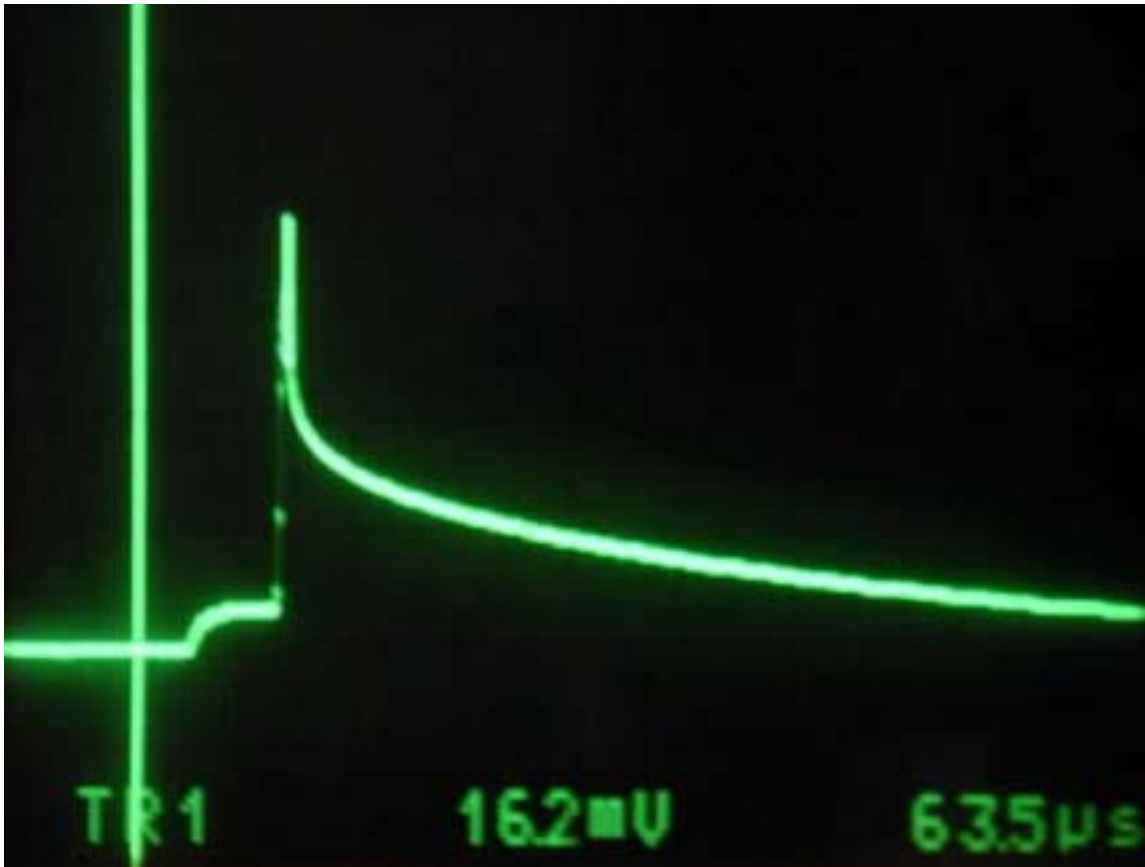

Figure 5. Clamp overshoot (at pulse output); horizontal scale = $50\mu\text{S}/\text{div}$, vertical scale = $50\text{mV}/\text{div}$, supply voltage = 4.5V , clamp overshoot = 162mV .

A similar version of this article appeared in the June 27, 2002 issue of *EDN* magazine.

Application Note 1186: <http://www.maxim-ic.com/an1186>

More Information

For technical questions and support: <http://www.maxim-ic.com/support>

For samples: <http://www.maxim-ic.com/samples>

Other questions and comments: <http://www.maxim-ic.com/contact>

Related Parts

MAX919: [QuickView](#) -- [Full \(PDF\) Data Sheet](#) -- [Free Samples](#)

AN1186, AN 1186, APP1186, Appnote1186, Appnote 1186

Copyright © by Maxim Integrated Products

Additional legal notices: <http://www.maxim-ic.com/legal>