

APPLICATION NOTE 1184

Understanding Analog Video Signals

Abstract: This paper describes the analog video signals used in both broadcast and graphics applications. Topics covered include video signal structure, video formats, standard video voltages, gamma correction, scan rates, and sync signals.

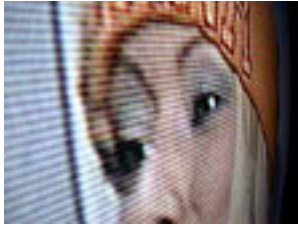

This paper describes the analog video signals used in both broadcast and graphics applications.

There are two forms of video in general use today: broadcast and graphics. While broadcast is based on terrestrial television, the graphics format was developed to meet

the needs of workstations and PCs without regard for the formatting and bandwidth limitations needed in TV signal transmission. The broadcast graphics format is specified by government agencies such as the FCC in the US and the ITU in Europe, while the graphics format is specified by industry or company standards. Originally, both formats shared a common baseband signal structure, specified in EIA-RS-170¹, but that changed when color was added to broadcast TV in 1953.

Monochrome TV required a single luminance signal and the required transmission bandwidth was moderate. A simple conversion to color, with the requirement for three video signals — one for each of the additive primaries of red, green, and blue (RGB) — would have tripled the required bandwidth. To circumvent that need, broadcast invented NTSC, PAL, and SECAM — analog encoding methods employed to squeeze color into the original monochrome channel bandwidth. In the process, broadcast invented all of the analog baseband formats used in video today. Graphics didn't require the limited bandwidth, and remains as three separate RGB channels.

The three formats for baseband video signals — native primaries, component, and composite — form a hierarchy that is the basis of all video, whether analog or digital, broadcast or graphic. We'll see how the formats are derived, and what sort of problems there are in handling them, and why. The issue of video quality is also discussed as a function of format.

Broadcast and graphics have other differences that are not immediately obvious. Broadcast video has a property called gamma (γ), which graphics lacks. Broadcast uses interlaced scanning while graphics uses progressive scanning. Two types of video displays developed because of these differences; one for TV and another for the PC. We'll look at why they are different and how they can share a display.

Broadcast and Graphics Analog Video Signal Structure

The signal structure of broadcast video is more complex than a graphics video signal because of the analog encoding process used in converting it to the composite signal² needed for modulating a TV transmitter. In this process, all the other video formats are created, starting from the native format³. The formats are native primaries, component, and composite video. Only broadcast video uses encoding. There are no component or composite video signals in a PC today.

Originally the PC used a TV format in the display. Graphics only has a single RGB format, but it has evolved to include multiple scanning rates for increased resolution. The need for higher resolution was driven by the short viewing distance, typically between one and three screen heights, compared to TV which is typically observed from six or more screen heights away. Based on a minimum resolvable area of one arc-second in the human

eye, a graphics display is enhanced greatly by increased resolution, while the TV wasn't until larger displays became available.

NTSC⁴, PAL⁵, and SECAM⁶ are the names of the broadcast video formats developed in the US, Germany, and France to encode color video and sound into a single signal. All reduce the quality of video in two ways: bandwidth reduction, and artifact generation. Bandwidth reduction reduces the resolution⁷, while artifacts are the crawling, or hanging, dots on an edge. The latter is the most objectionable to viewers, while the former is seldom noticed.

The broadcast video formats have these characteristics in common:

- All use amplitude to encode the "Luma" portion of a signal (Y') as the weighted sum of R', G', and B'.
- All have a reduced-bandwidth component-video form.
- All use subcarrier(s) phase or frequency to encode color or "Chroma".
- All include sound subcarrier(s).
- All result in a single wire form called composite video, suitable for terrestrial RF transmission.

Video formats can be viewed as a hierarchy⁸ (Figure 1):

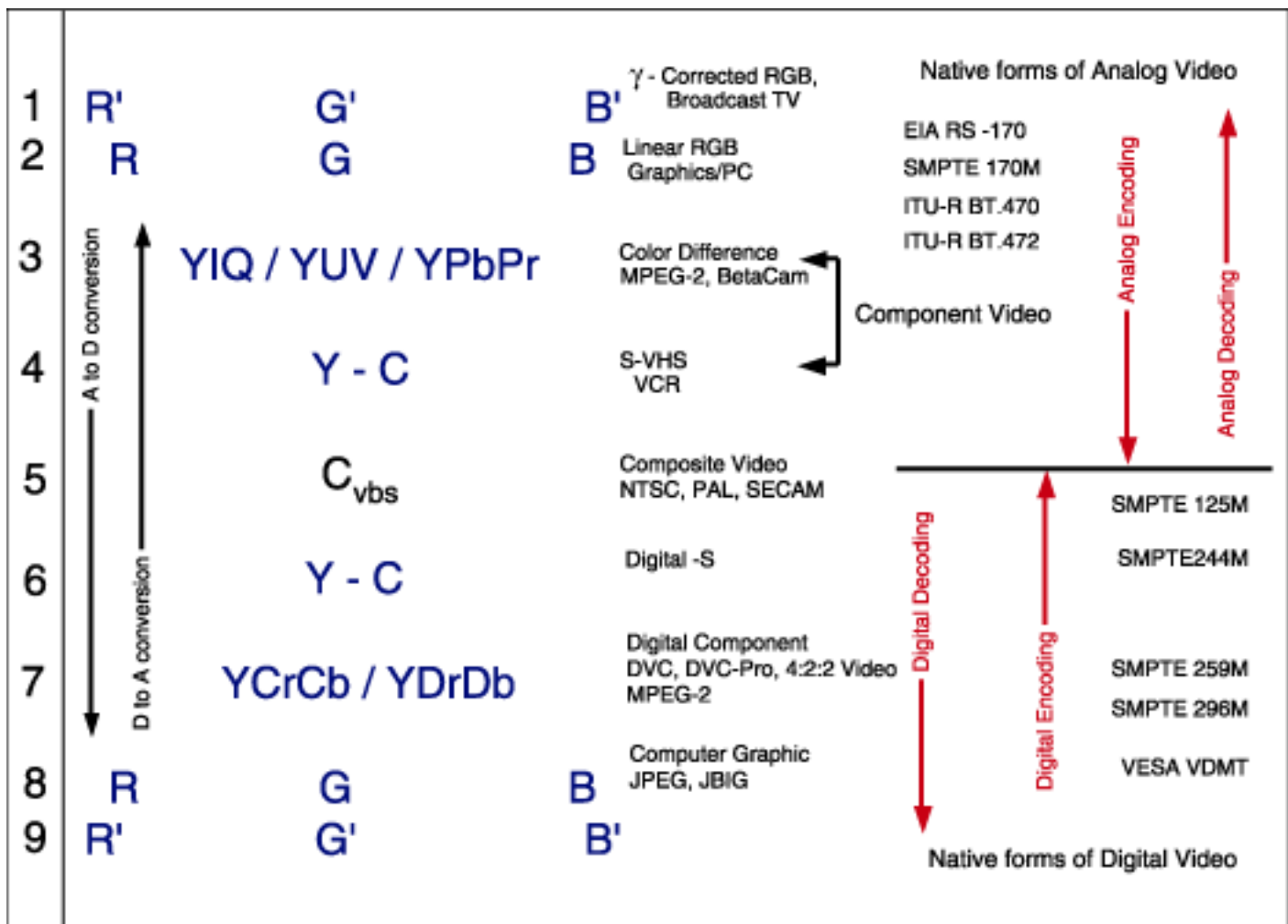

Figure 1. The hierarchy of video.

Native Primaries

The first line in the hierarchy is R', G', B', where the prime mark (') indicates gamma (γ) correction. This is the native form of broadcast video. The second line is linear RGB, the native form of graphics, with no prime mark. This convention is misused in some texts, making it difficult to follow through the literature. Here, we'll use a prime to indicate the γ -corrected form, in accordance with the SMPTE and ITU standards in Figure 1.

The bandwidth of the signals RGB and R'G'B' are equal and determined by the video resolution⁹. This is as good as it gets. Any further signal processing degrades the video quality, which is why graphics stuck with RGB. A viewer may not perceive this degradation if human vision or the display can't resolve it. Broadcast used human perception factors to design the composite signal for TV. HDTV, PAL plus, and MPEG all later rejected composite and native primaries, and decided to use the next form — called component video — to improve video quality.

Component Video

The third and fourth lines are the two forms of component video, color difference (Y'PbPr/Y'UV/Y'IQ) and Luma-Chroma (Y'-C)¹⁰. Sometimes, there is confusion about the terms used. Some texts use the terms Luminance and Chrominance, which are from Color Science. Here we'll use Luma and Chroma where the Luma term is written with a prime (Y') to indicate the non-linear video form.

The Color Difference form is produced by the linear addition and scaling of R'G'B' to implement the well-know equations;

$$Y' = (K_r \times E_r') + (K_g \times E_g') + (K_b \times E_b')$$

$$P_b, U, I = K_{cb} \times (B' - Y')$$

$$P_r, V, Q = K_{cr} \times (R' - Y')$$

The coefficients for Luma (K_r, K_g, K_b), are the same for NTSC, PAL, and SECAM, but the coefficients for the difference terms (K_{cr} and K_{cb}) vary according to the process. It is important to remember that the equations apply to the active video portion of the signal and not the sync. They must be separated prior to this process, and combine them again afterwards.

One of the challenges with multiple video signals is that of controlling delay. In order to display an image, the video voltages must be correctly aligned in time. Two types of delay prevent this, flat delay caused by the transmission path length and frequency-dependent delay caused by filters. This applies to R'G'B' and component video. Flat delay is seldom a problem at video frequencies, and any required compensation can be made either by coax cable or delay lines. Frequency-dependent delay is another matter.

Because the R', G', and B' signals all have the same bandwidth, flat delay is seldom a problem, but the Chroma portions of the component signals (P_b , P_r & C) are filtered to reduce the occupied bandwidth. To compensate for the delay associated with this filtering, the Luma signal (Y) must be delayed the same amount.

The Chroma filtering is considered "visually lossless", based on a model of human vision that says the eye doesn't detect small details in color. The analog videotape format of Beta¹¹ is an example of a scaled color-difference format, and S-VHS¹² is an example of the Y-C form.

MPEG uses a digitized form of the color-difference signals, designated YCbCr, and shown on the seventh line, where the bandwidth reduction is done by sampling Cb and Cr at half the rate of the Y channel. This is called 4:2:2 sampling, and is based on ITU-R BT.601.

The Y-C component form is produced by phase- or frequency- modulating color subcarrier(s) with the color-difference components, and then adding them together depending on which process is used. The Y channel is the same as in YPbPr, but the Chroma signal is an FM or PM subcarrier that is band-pass filtered, further truncating the color bandwidth.

This is an important point in the encoding process. It's the last place where Luma and Chroma information are separate. Once Y and C are combined, they will never again be totally separated, and that produces the artifacts that give composite its reputation for compromised quality.

Composite Video

The fifth, and center, line is composite video (Cvbs), formed by adding the Luma and Chroma components together with monaural audio, NTSC, PAL and SECAM are composite video signals.

The Cvbs signal is the lowest quality video on the chart and suffers from cross-color artifacts. These are bits and pieces of Chroma and Luma information that remain after we try to separate Cvbs back into R',G', & B' for display. These artifacts became more noticeable as broadcast began to use larger, higher-quality displays. Today, Cvbs is more of a legacy format, and will probably disappear as single-wire digital forms of component video take its place.

One odd thing about NTSC Cvbs is something called "setup." This is a voltage offset between the "black" and "blanking" levels, and is unique to NTSC. As a result, NTSC is more easily separated from its sync portion, but has a smaller dynamic range when compared with PAL or SECAM.

The Video formats are also called color spaces in digital literature, and the encoding/decoding process is called color-space conversion to distinguish it from the analog process. Don't be confused by this — digital video uses the same formats as analog video. The signals produced by the encoding process are shown in **Figure 2**, along with approximate amplitudes, in percent. Exact amplitudes are given in Table 1 for several of the formats, based on a 1V p-p R'G'B' set of native primaries, across a 75Ω load. These are the signal values you will see going into or out of video equipment like displays, VCRs, and DVD players.

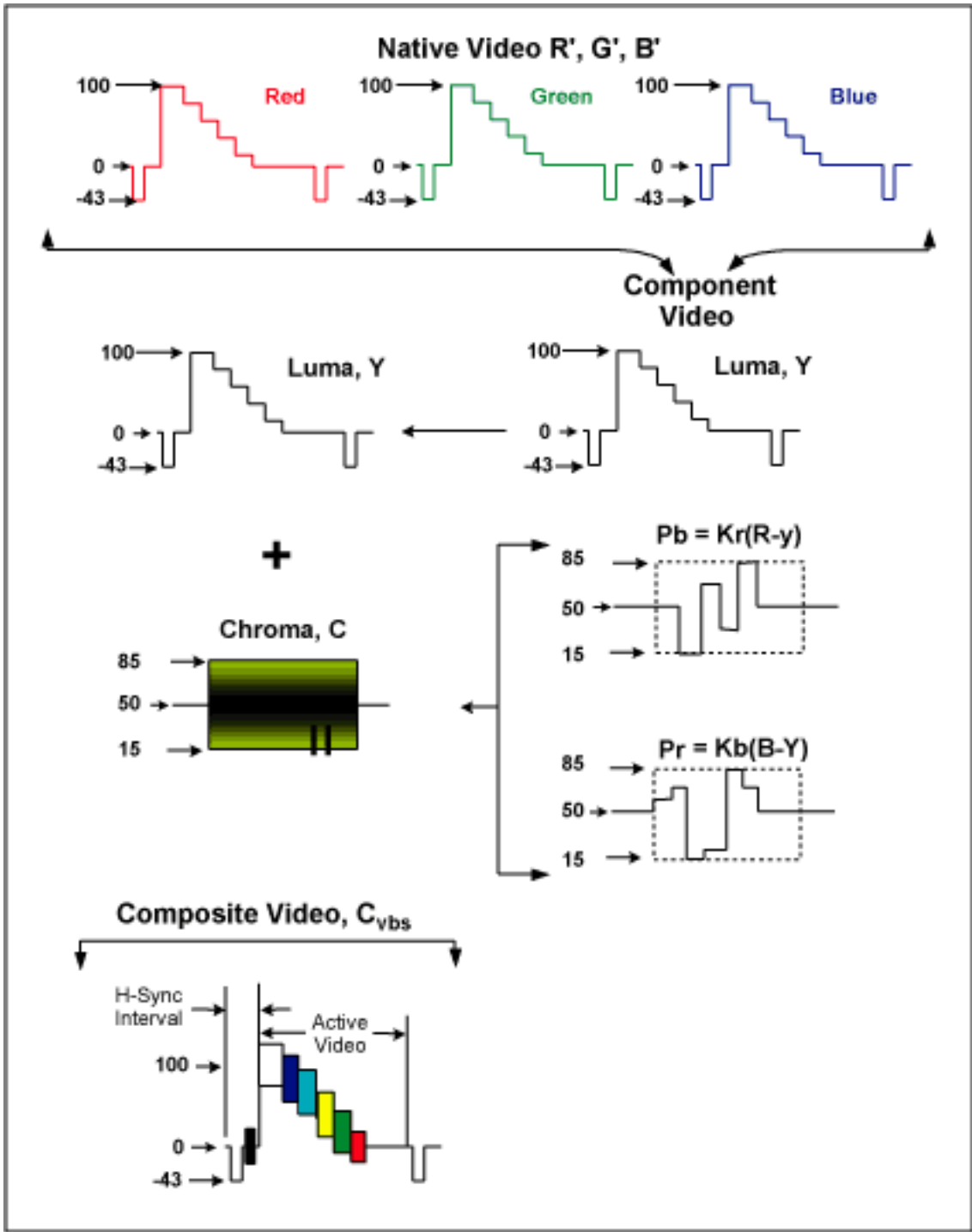

Figure 2. Analog encoding from $R'G'B'$ to C_{vbs} .

Table 1. Standard Video Voltages

R'G'B Video			
NTSC		PAL	
Setup	53.6 mV	Setup	0 mV
R'G'B'	714 mV (Peak Luma, 100% White)	R'G'B'	700 mV (Peak Luma, 100% White)
Sync	-286 mV	Sync	-300 mV
NTSC Japan		Graphics Linear RGB	
Setup	0 mV	Setup	0 mV
R'G'B'	714 mV (Peak Luma, 100% White)	R'G'B'	700 mV (Peak Luma, 100% White)
Sync	-286 mV	Sync	-300 mV
Color Difference Component Video			
NTSC BetaCam		PAL BetaCam/EBU N10	
Setup	53.37 mV	Setup	0 mV
Y	714.29 mV (Peak Luma, 100% White)	Y	700.00 mV (Peak Luma, 100% White)
Pb/Pr	700.00 mVp-p (75% Color Bars) 933.34 mVp-p (100% Color Bars)	Pb/Pr	525.00 mVp-p (75% Color Bars) 700.00 mVp-p (100% Color Bars)
Sync	-286 mV	Sync	-300 mV
NTSC BetaCam Japan			
Setup	0 mV		
Y	714.30 mV (Peak Luma, 100% White)		
Pb/Pr	756.80 mVp-p (75% Color Bars) 1009.0 mVp-p (100% Color Bars)		
Sync	-286 mV		
Y-C Component Video			
NTSC S-VHS		PAL S-VHS	
Setup	53.57 mV	Setup	0 mV
Y	714.29 mV (Peak Luma, 100% White)	Y	700.00 mV (Peak Luma, 100% White)
V	626.70 mVp-p (75% Color Bars) 835.60 mVp-p (100% Color Bars)	C	663.80 mVp-p (75% Color Bars) 885.10 mVp-p (100% Color Bars)
Sync	-286.00 mV	Sync	-300.00 mV
Composite Video			
NTSC		PAL	
Setup	54 mV	Setup	0 mV
Video	714 mV (Peak Luma, 100% White) 934.15 mV (Peak Luma with 100% Color Bars)	Video	700 mV (Peak Luma, 100% White) 933.85 mV (Peak Luma with 100% Color Bars)
Sync	-286 mV	Sync	-300 mV
Burst	286 mVp-p	Burst	300 mVp-p
NTSC-EIA-J			
Setup	0 mV		
Video	714.0 mV (Peak Luma, 100% White) 908.2 mV (Peak Luma with 100% Color Bars)		
Sync	-286.0 mV		
Burst	286.0 mVp-p		

Linear and Gamma Corrected Video

Originally, video signals were created in cameras using vacuum tube sensors. The output voltage (V) of a tube camera isn't linear in relation to the incident light (B). It's exponential and the exponent is called gamma (γ). This relationship can be mathematically expressed as

$$B = K \times V^\gamma.$$

where B is light flux, in lumens per square meter. K is a constant; and V is the voltage generated, in Volts. Since the CRT is also a vacuum tube, with inverse non-linearity ($1/\gamma$) similar to that of the camera tube, the light output is linear with respect to the light input — that is, the inverse gamma of the picture tube compensates for the gamma function of the camera's pickup tube. However, the voltage is non-linear compared to the luminance level. This poses a challenge when superimposing two images since you cannot do simple linear addition of, say, a title or other graphic. Video mixers deliver odd results with broadcast signals because of their non-linear luminance. Special-effects generators use linear signals when layering, compositing, titling, etc. Graphics video is linear, which makes it easy to mix graphics video signals. The linear signal is gamma corrected at the display, so it will appear correctly on the display, to allow for the display's gamma.

A beneficial side effect of gamma is that it reduces the effect of additive noise.

Gamma is specified as 2.22 for NTSC and as 2.8 for PAL and SECAM.

Originally, the camera and CRT were thought to be exactly complementary, but they are not. Later it was found that intentionally under-compensating for γ in the display improved the contrast ratio. Because of that, Sun and Apple, optimized their displays with values of 1.7 and 1.45, respectively, while others use broadcast values. Today, TV and PC display manufacturers all undercompensate for γ to some degree to improve the appearance of the display.

One thing is certain. You'll need to be able to add, remove, or change γ to fit the video signal. This is called γ correction in some texts, which is the addition of γ to a linear RGB signal. It's really more in the nature of a γ modification.

Gamma Modification

The addition, removal, or change of γ can be done in either the analog or digital domain. In analog, it takes the form of a non-linear amplifier where one of the gain resistors around an op-amp is replaced by a real or a piece-wise equivalent to a non-linear impedance. This is non-trivial in terms of design. Analog γ correctors are seldom accurate, and they require trimming adjustments. A side effect of γ modification is distortion. For these reasons, γ correction is best done digitally. Note that this only applies to the active video, not to the sync.

The digital process uses substituted values from a look-up table (LUT) stored in software. It's as accurate as the stored value, and trivial in terms of its design. Obviously if the signal is digital, this is the preferred method to use. In either case, we need a formula for the voltage in terms of the light flux (B). Broadcast video has two, one used for standard-definition TV (SDTV), and another for HDTV.

For NTSC/PAL per SMPTE170M and ITU-R BT.709;

$$E'_x = [(1.099 \times B^{(0.45)}) - 0.099] \text{ for } 0.018 > B > 1.0$$

$$E'_x = [4.5 \times B] \text{ for } 0 > B > 0.018$$

For HDTV per SMPTE240M;

$$E'_x = [(1.1115 \times B^{(0.45)}) - 0.1115] \text{ for } 0.0228 > B > 1.0$$

$$E'_x = [4.0 \times B] \text{ for } 0 > B > 0.0228$$

Scanning and Sync

Video signals have two parts: the active video and sync. We have so far only looked at the active video. The proper name for sync is Image Reconstruction Timing, and it's used to reconstitute the image. The sync portion doesn't interfere with the active video because it's below the black level and can't be seen. Any signal below the black level is said to be blanked. The black and blanking level are the same in every format except NTSC composite. Originally, the black, or blanking level was at 0Volts, with active video above and sync below, to simplify separating them based on level and timing.

If you could spread out the active video and sync interval on a flat surface, you would get a raster, which looks like **Figure 3**. The unused portion, $T_2(H)$ to $T_3(H)$, originally allowed magnetically-scanned CRTs to "fly back" to their starting point for the next line, and settle during $T_0(H)$ to $T_1(H)$. The vertical deflection works in a similar manner. The sync interval is "dead time" as far as the active video is concerned. Consequently, there are two resolutions for a video format, the active-video resolution we see, and the total resolution¹³ of the raster. This is true for both broadcast and graphics. The image quality is a function of the active-video resolution¹⁴ and the bandwidth through which the signal is transmitted.

A raster is created by scanning, both horizontally and vertically, starting at the upper left corner of the display. These "scan lines" are synchronized by the horizontal sync pulse, or H-Sync, so that they all start at the same place on the display. The frame, or V-Sync, indicates when the scan is finished and when to start the next. This means the image is sampled at the frame rate, and any motion that's faster than $1/2V\text{-Sync}$ will produce "aliasing" in the reconstructed image.

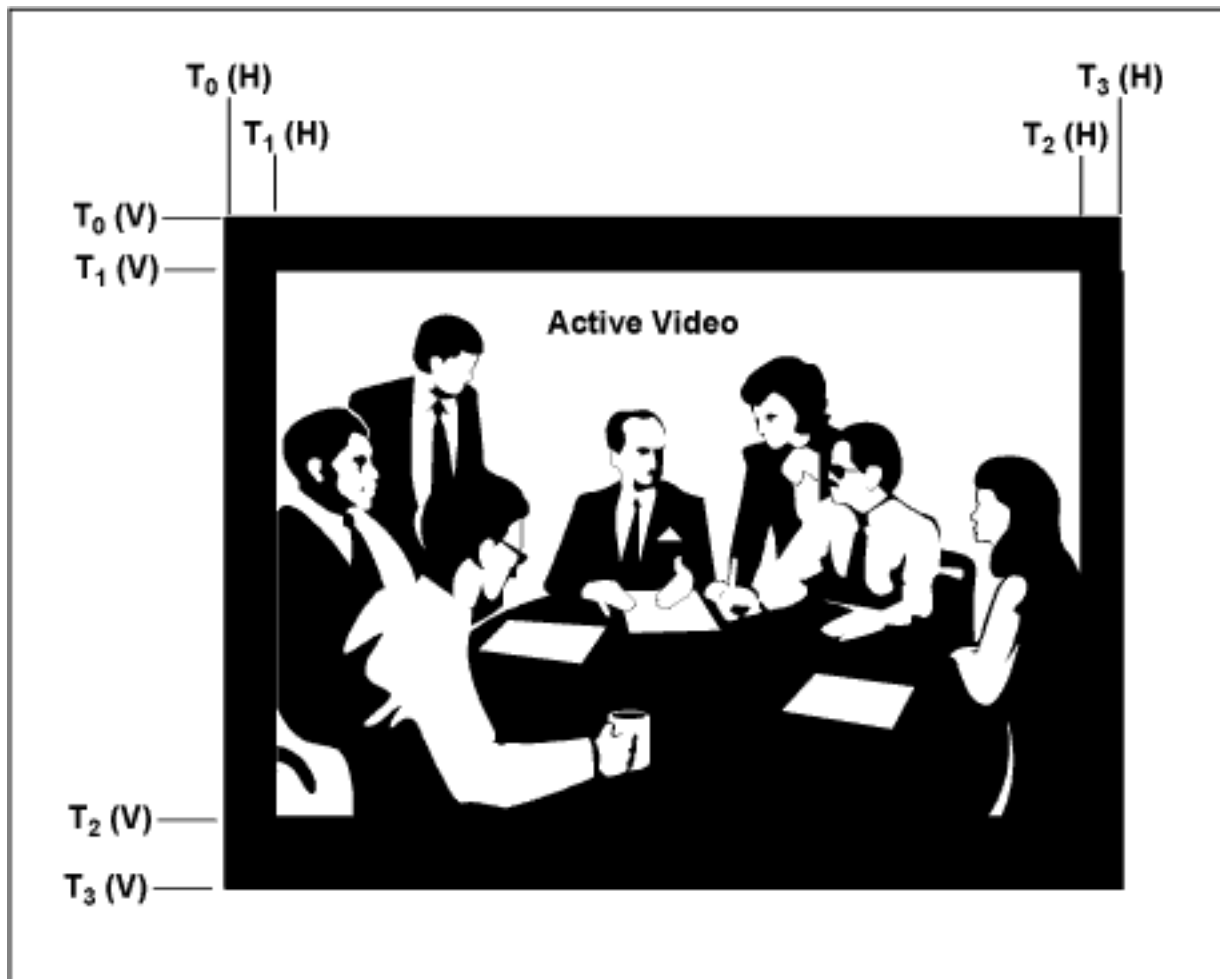

Figure 3. Display raster with horizontal and vertical flyback time.

In RS-170, the frame rate was split into odd and even fields — a process called interlaced scanning — to conserve bandwidth. Visually this has the effect of re-sampling the displayed image faster and avoids flicker without increasing the frame rate — and bandwidth — in broadcast. The addition of a color subcarrier modified

this sequence. In NTSC, the phase of the color subcarrier reverses every field, and in PAL, it indexes 90° per field. This gives rise to the 4, and 8 color field sequences for the NTSC and PAL composite signals. Graphics uses progressive scanning, since the increased bandwidth isn't a problem.

A side effect of the vertical sampling is that if you AC couple a video signal, you must still have good square-wave response at the field (broadcast), or frame rate (graphics). If you don't, you'll get brightness variations across the raster. This can be seen in a vertically-split black and white screen pattern. Very large capacitors (>330μF) are required to maintain good square-wave response when AC coupling an output because of the 75Ω circuit.

The scanning method and rate varies between the different types of video. In order to share a display, the Multi-Sync™ concept was invented. Originally, these displays had a deflection system that could respond to the different rates by switching component values. As long as the display had sufficient resolution to display the highest scan rates, this worked fine. It displayed each type of video with its native scanning format, but this can be expensive since the display must be sized to the highest resolution and speed.

The alternative is to scan the display at a constant rate, and convert the incoming video to the display rate. This is called scan conversion. It allows the display to operate at a single resolution, making the deflection simpler. Scan conversion is best done in the digital domain using dual-ported video RAM.

Video Groups and Specifications

NTSC: National Television System Committee. The US form of standard definition TV.

PAL: Phase Alternating Line. The system of standard definition TV implemented in Europe and elsewhere.

SECAM: Sequential Couleur avec Memoire. The French form of standard definition TV.

ATSC: Advanced Television Systems Committee. The US form of high definition TV (HDTV).

VESA: Video Electronics Standards Association. Proposes and publishes video standards for Graphics.

ITU: International Telecommunications Union. Proposes and publishes video standards for Broadcast in the EU.

SMPTTE: Society of Motion Picture and TV Engineers. Proposes and publishes video standards for Broadcast in the US.

JPEG: Joint Photographic Experts Group. Proposes and publishes video standards for Still Images.

MPEG: Motion Picture Experts Group. Proposes and publishes video standards for Broadcast.

EIA RS 170 & 170A The original specs for Monochrome and Color TV in the US. Has been replaced by SMPTTE 170M.

EIA 770-1: The US spec for Enhanced Component video, similar to ITU-R BT1197/ETSI 300 294 for PAL-Plus.

EIA 770-2: The US specs for Standard Definition TV (SDTV) Baseband Component Video.

EIA 770-3: The US spec for High Definition TV (HDTV) Baseband Video.

ITU-R BT.470: Harmonized spec for SDTV world wide, including NTSC, PAL, and SECAM.

ITU-R BT.601: Universal Sampling spec for SDTV and HDTV Broadcast Video. Similar to SMPTTE125M.

ITU-R BT1197/ETSI 300 294: Spec for PAL Plus Enhanced TV in Europe.

SMPTTE 125M: Similar to ITU-R BT.601.

SMPTTE 170M: Has replaced EIA RS 170A, color spec for NTSC.

SMPTTE 253M: RGB Analog Video Interface spec for SDTV Studio applications.

SMPTTE 274M: Component spec for 1920x1080 HDTV.

SMPTTE 296M: Spec for 1280 x 720 RGB and YPbPr Baseband Video. Similar to PAL Plus.

Table 2. Graphic Standards and Active Resolutions

GRAPHICS STANDARD	HORIZONTAL RESOLUTION	VERTICAL RESOLUTION	HORIZONTAL FREQUENCY (kHz)	VERTICAL REFRESH RATE (Hz)	PIXEL/SAMPLE RATE (MHz)
VGA	640	480	31.5	60	25.175
	640	480	37.7	72	31.5
	640	480	37.5	75	31.5
	640	480	43.3	85	36
SVGA	800	600	35.1	56	36
	800	600	37.9	60	40
	800	600	48.1	72	50
	800	600	46.9	75	49.5
	800	600	53.7	85	56.25
XGA	1024	768	48.4	60	65
	1024	768	56.5	70	75
	1024	768	60	75	78.75
	1024	768	64	80	85.5
	1024	768	68.3	85	94.5
SXGA	1280	1024	64	60	108
	1280	1024	80	75	135
	1280	1024	91.1	85	157
UXGA	1600	1200	75	60	162
	1600	1200	81.3	65	175.5
	1600	1200	87.5	70	189
	1600	1200	93.8	75	202.5
	1600	1200	106.3	85	229.5
QXGA	2048	1536		60	260
	2048	1536		75	315

Choosing A Video IC

Tables 3 and 4 show large-signal bandwidth ($2V_{p-p}$), slew rate, differential gain and phase, and supply voltage for Maxim's most popular video drivers, buffers, and receivers with single-ended and differential outputs.

A special subset of the video driver is the video-distribution amplifier (see Table 5). Built to drive multiple loads, they offer higher isolation, selectable outputs, fixed or settable gain and are often used in professional equipment.

Another subset of the video driver is the video mux-amp (see Table 6). Mux-amps combine a video multiplexer and a video line driver for routing video signals.

Analog Video Filters maybe used to eliminate many discrete components and save board space in video reconstruction applications(see Table 7.)

Table 3. Single-Ended Video Line Drivers and Buffers

P/N	No. of Amps	Operating Voltage (V)	-3dB LSBW (MHz)	Slew Rate (V/ μ s)	DP/DG ($^{\circ}$ /%)	Notes
MAX4090	1	+3,+3.3, +5	55	275	0.8/1.0	SC70, 3V, 150nA Shutdown, Input Clamp
MAX4032	1	+5	55	275	0.6/0.4	SC70, 5V, Sag Corrected Output
MAX4450/1	1 / 2	+5, \pm 5	175	485	0.08/0.02	SC70/SOT23 Packages
MAX4350/1	1 / 2	\pm 5	175	485	0.08/0.02	SC70/SOT23 Packages
MAX4380-4	1 / 2 / 3 / 4	+5, \pm 5	175	485	0.08/0.02	SC70/SOT23 Packages, Disable Available
MAX4389-96	1 / 2 / 3 / 4	+5, \pm 5	127	200	0.015/0.015	SC70/SOT23 Packages, Disable Available
MAX4108 MAX4109 MAX4308 MAX4309	1 1	+5,+/-5	400 225 220 200	1200	0.004/ 0.008	LOW Distortion, Stable Gain, 1,2,5,10 MAX4108 0.1db/2V _p - p BW is 100MHz.
MAX4012/ 16/ 18/ 20	1 / 2 / 3 / 4	+3.3, +5, \pm 5	140	600	0.02/0.02	Disable Available
MAX4212/ 13/ 16/ 18/ 20	1 / 2 / 3 / 4	+3.3, +5, \pm 5	180	600	0.02/0.02	Disable Available
MAX4014/ 15/ 17/ 19/ 22	1 / 2 / 3 / 4	+3.3, +5, \pm 5	140	600	0.02/0.04	Gain of 2 Buffer, Disable Available
MAX4214/ 15/ 17/ 19/ 22	1 / 2 / 3 / 4	+3.3, +5, \pm 5	220	600	0.02/0.04	Gain of 2 Buffer, Disable Available
MAX477	1	\pm 5	200	1100	0.01/0.01	130MHz 0.1dB Gain Flatness

Table 4. Differential Video Line Drivers and Receivers

P/N	Driver / Receiver	Operating Voltage (V)	-3dB LSBW (MHz)	Slew Rate (V/ μ s)	DP/DG ($^{\circ}$ /%)	Notes
MAX435	Driver	\pm 5	275	800	Not Specified	300 μ V Input Offset Voltage
MAX4142	Driver	\pm 5	180	1400	0.01/0.01	Fixed Gain of 2V/V
MAX4147	Driver	\pm 5	250	2000	0.03/0.008	Fixed Gain of 2V/V
MAX4447/8/9	Driver	\pm 5	405	6500	0.01/0.02	Single-Ended Input
MAX436	Receiver	\pm 5	275	800	Not Specified	300 μ V Input Offset Voltage
MAX4144/5/6	Receiver	\pm 5	110	1000	0.03/0.03	Shutdown Mode
MAX4444/5	Receiver	\pm 5	500	5000	0.05/0.07	Shutdown Mode

Table 5. Distribution Amplifiers

P/N	No. of Outputs	Operating Voltage (V)	-3dB LSBW (MHz)	Slew Rate (V/ μ s)	DP/DG ($^{\circ}$ / %)	Notes
MAX4135/6	6	± 5	185	1000	0.1/0.1	0.1dB Gain Flatness to 40MHz
MAX4137/8	4	± 5	185	1000	0.1/0.1	0.1dB Gain Flatness to 40MHz

Table 6. Video Mux-Amps

P/N	Inputs: Outputs	Operating Voltage (V)	-3dB LSBW (MHz)	Slew Rate (V/ μ s)	DP/DG ($^{\circ}$ / %)	Notes
MAX4023-6	2: 1	+5, ± 5	260	300	0.05/0.012	Low Cost, Fixed and Settable Gain
MAX4028/9	2: 1	+5	210	300	0.4/0.2	Fixed Gain of 2 with Input Clamps
MAX4310	2: 1	+5, ± 5	110	460	0.06/0.08	Unity Gain Stable
MAX4311	4: 1	+5, ± 5	100	430	0.06/0.08	Unity Gain Stable
MAX4312	8: 1	+5, ± 5	80	345	0.06/0.08	Unity Gain Stable
MAX4313	2: 1	+5, ± 5	40	540	0.09/0.03	Fixed Gain of 2
MAX4314	4: 1	+5, ± 5	90	430	0.09/0.03	Fixed Gain of 2
MAX4315	8: 1	+5, ± 5	70	310	0.09/0.03	Fixed Gain of 2

Table 7. Video Reconstruction Filters

P/N	Channels	Operating Voltage (V)	Gain (dB)	Output Video Buffer	High Frequency Boost	Notes
MAX7450-2	1	±3, ±5	0, 6	Yes	No	Video Conditioner with AGC and Back Porch Clamp
MAX7449	3	5	6	Yes	No	3-Channel RGB Video Filter
MAX7448	4	5	6	Yes	Yes	4-Channel RGB Video Filter with CVBS input
MAX7447	4	5	6	Yes	Yes	4-Channel S-Video, CVBS Video Filter with CVBS input
MAX7446	4	5	6	Yes	Yes	4-Channel RGB and CVBS Video Filter
MAX7445	4	5	6, 9.5, 12	Yes	Yes	4-Channel Video Filter with selectable gain
MAX7443/4	3	5	6, 9.5, 12	Yes	Yes	3-Channel Video Filter with selectable gain
MAX7440-2	6	5	0	No	Yes	6-Channel Video Filters with HF Boost
MAX7438/9	3	±5	6, 9.5	Yes	Yes	3-Channel, Back-Porch Clamp to GND
MAX7428/30/32	1, 2, 3	5	6	Yes	Yes	1-, 2-, or 3-Channel Filter, 2:1 input Mux.

Table 8. SCART Audio/Video Switches

P/N	SCART Connectors	Operating Voltage (V)	-3dB LSBW (MHz)	Gain (dB)	DP/DG (°/%)	Notes
MAX4399	3	+5, +12	27	±1, 6	0.36/0.13	SCART Audio/Video Switch for Digital Set-top Boxes
MAX4397	2	+5, +12	6	±1, 6	0.4/0.2	SCART Audio/Video Switch for Digital Set-top Boxes

Notes:

1. RS-170 was replaced by SMPTE 170M.
2. Cvbs usually means "composite video, with blanking and sound."
3. The native form is that in which the signal was created. Usually it is R'G'B', the g-corrected primaries.
4. NTSC is the National Television Systems Committee system of analog encoding.
5. PAL is the Phase Alternating Line system of analog encoding.
6. SECAM is the Sequential Couleur avec Memoire system of analog encoding.
7. [Bandwidth versus video resolution](#)
8. The exact form and process information for Terrestrial Broadcast can be found in ITU-R BT.470.
9. [Bandwidth versus Video Resolution](#)
10. The Y Component is often called "Luminance," and confused with the color science term. We use the term Luma, and designate it with an accent, Y'.
11. Trademark of Sony Corp.
12. Trademark of JVC.
13. Total resolution is also called format resolution.
14. [Bandwidth versus Video Resolution](#)
15. This is the Nyquist frequency of the image-sampling process.

Application Note 1184: <http://www.maxim-ic.com/an1184>

More Information

For technical questions and support: <http://www.maxim-ic.com/support>

For samples: <http://www.maxim-ic.com/samples>

Other questions and comments: <http://www.maxim-ic.com/contact>

AN1184, AN 1184, APP1184, Appnote1184, Appnote 1184

Copyright © by Maxim Integrated Products

Additional legal notices: <http://www.maxim-ic.com/legal>