

Application Note:

HFAN-04.5.1

Rev.1; 04/08

Measuring Random Jitter on a Digital Sampling Oscilloscope



Maxim Integrated Products



Measuring Random Jitter on a Digital Sampling Oscilloscope

1 Overview

Random jitter is playing an increasingly important role in today's high-speed digital communication systems. For example, SONET specifies that an optical transceiver has no more than $10\text{mUI}_{\text{RMS}}$ of random jitter. ($1\text{UI} = 1 \text{ Unit Interval} = 1 \text{ bit period}$). This would mean for a 10Gbps system, the random jitter must be less than or equal to 1ps_{SRMS} . This application note describes an improved technique for measuring sub-picosecond random jitter.

In order to meet the $10\text{mUI}_{\text{RMS}}$ requirement in a 10Gbps transmitter, each device in the transmitter must contribute significantly less than $10\text{mUI}_{\text{RMS}}$. Measurements of this sort on an oscilloscope become problematic, especially when the oscilloscope jitter can be larger than the jitter contributed by the DUT (device under test).

By using the techniques in this application note, the random jitter contributed by the Tektronix CSA8000 oscilloscope (specified as $1.5\text{ps}_{\text{SRMS}}$ max) was reduced by $1.38\text{ps}_{\text{SRMS}}$. This reduction allows more accurate measurement of the random jitter of a DUT.

2 Traditional Method of Measuring Random Jitter on an Oscilloscope

Random jitter is often measured as the standard deviation of the zero crossing of the signal edge using the histogram mode of the oscilloscope.

To avoid measuring deterministic jitter components, measure only the same edge of a repeating pattern. For more information on types of jitter refer to the ["Jitter in Digital Communication Systems, Part 1" Maxim Application Note, HFAN-04.0.3.](#)

However with the traditional method, the oscilloscope's random jitter contributes to the

measurement. This becomes significant when the oscilloscope's random jitter is in the same order of magnitude as the DUT's random jitter.

3 Understanding Random Jitter on an Oscilloscope

Current oscilloscope technology requires sequential digital sampling to achieve the bandwidth required to measure multi-gigabit systems.

The oscilloscope contributes to the jitter measurement because of jitter in the trigger-delay circuitry. Trigger-delay jitter is the time error between when the data is sampled and when the data should have been sampled. The cause of the trigger-delay jitter is the same as for other sources of random jitter: varying temperature, imperfect components, and external noise sources. See Figure 1 for a representation of trigger-delay jitter.

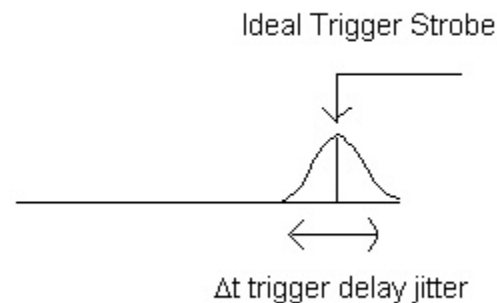

Figure 1. Trigger-delay jitter

The random jitter for the digital sampling Tektronix CSA8000 oscilloscope is specified as $1.0\text{ps}_{\text{SRMS}}$ typical, $1.5\text{ps}_{\text{SRMS}}$ max. Since the random jitter of the oscilloscope could be potentially larger than the allowable random jitter of the part, careful consideration must be paid to reduce the random jitter of the oscilloscope.

The time error between when the data is actually sampled, and when it should be sampled; or the sampling error, caused by the trigger-delay jitter, follows the standard theories associated with random jitter. The trigger-delay jitter is random in nature and has a Gaussian distribution. On a dual-input sampling head of an oscilloscope, the amount of trigger-delay jitter will be the same on both inputs because both channels will sample off of the same trigger strobe. Further, any time delay between the channels on a dual-input sampling head (usually created by the user programming a delay on one of the channels) will cause each channel to be sampled at different trigger strobes. On two separate sampling heads, the trigger strobe will never occur at identical moments, causing the trigger-delay jitter to be different.

4 Affects of Trigger-Delay Jitter

The oscilloscope measures and displays the instantaneous voltage of the DUT for every trigger strobe. If there is jitter on the trigger strobe (trigger-delay jitter), then the instantaneous voltage is measured but displayed at wrong times.

If the display is incorrect at the zero crossing, then the random jitter measurement will be incorrect. This is because random jitter is measured as the standard deviation of a single edge at the zero crossing, measured using the histogram mode of the oscilloscope. Since trigger-delay jitter will affect the measurement at the zero crossing, the random jitter measurement will be incorrect.

See Figure 2 for an illustration of how the trigger-delay jitter yields non-ideal values.

5 Finding and Removing the Sampling Error

Figure 2 shows the sampling error for a particular trigger event. The goal of the improved method is to remove the trigger-delay jitter for every trigger strobe, and measure only the DUT random jitter.

Before finding the sampling error, it is crucial to understand that trigger-delay jitter is timing error, not voltage error. Further, the oscilloscope can only measure voltages; it cannot measure any time values. However, the trigger-delay jitter causes the voltage

measurement to be displayed incorrectly. Therefore the error in the displayed voltage is directly related to the trigger-delay jitter. Thus, it is possible to find the relation between the displayed voltage and the amount of trigger-delay jitter. This is the key point that aids in finding the Δt (error caused by the trigger-delay jitter) of Figure 2.

There is a logical step-by-step method for finding the Δt error on an oscilloscope. It is impossible to find the Δt error solely by using the DUT output because when connected to the oscilloscope, the DUT output consists of both the DUT's random jitter, as well as the errors caused by the trigger-delay jitter.

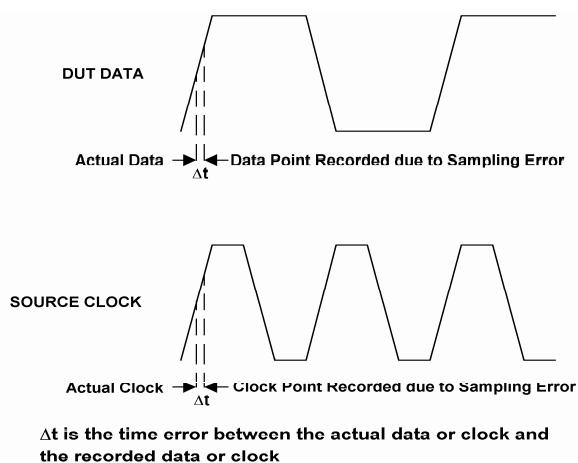

Figure 2. Error Caused by Non-Ideal Sampling

To overcome this hurdle, a separate reference signal is used. This reference signal should have little to no random jitter; such a signal is found in the clock output of the pattern generator.

If the clock output is connected to the same input head as the DUT's output, then the trigger-delay jitter will be equivalent for the two. Since the clock output has negligible random jitter, any random jitter displayed on the oscilloscope will be caused by the trigger-delay jitter.

The key is to find the trigger-delay jitter on the reference signal. If both the reference signal and DUT signal are connected to the same sampling head their trigger-delay jitter will be equivalent. Since the reference signal and DUT signal will have the same amount of trigger-delay jitter, it will be

possible to remove this jitter by finding the trigger-delay jitter on only the reference signal.

However finding the trigger-delay jitter on the reference signal is not trivial because trigger-delay jitter is a timing error, and the oscilloscope is displaying voltages at incorrect times. Therefore the first step of removing trigger-delay jitter is to find the error in the voltage measurement of the clock signal. Next, convert that voltage value to a time value that will be the trigger-delay jitter on the clock output. Since the clock output and data output are on the same sampling head, the trigger-delay jitter on the data output will be the same as the trigger-delay jitter on the clock. The oscilloscope needs voltage values, therefore the next step is to convert the trigger-delay jitter back to a voltage error. Finally, subtract the voltage error from the DUT signal. The result will include only jitter caused by the DUT, and no trigger-delay jitter from the oscilloscope. This makes it possible to measure only the DUT's random jitter, without jitter caused by the oscilloscope affecting the measurement.

The following five subsections describe the methodology of finding error caused by the trigger-delay jitter on an oscilloscope. The subsections will go over the theory of the improved random jitter measurement. These steps will be carried out in Section 7 when the system is actually connected. The variables the subsections will use are ΔV_{REF} , Δt_{REF} , Δt_{SIGNAL} , and ΔV_{SIGNAL} . ΔV_{REF} is the voltage error on the oscilloscope display caused by the trigger-delay jitter. Δt_{REF} is the trigger-delay jitter added on to the reference signal. Δt_{SIGNAL} is the trigger-delay jitter on the DUT's signal. And finally, ΔV_{SIGNAL} is how much trigger-delay jitter has affected the display on the oscilloscope of the DUT's voltage measurement.

The first step in removing the trigger-delay jitter is to find the measurement voltage error (ΔV_{REF}) caused the trigger-delay jitter.

5.1 Finding ΔV_{REF}

ΔV_{REF} is the voltage error of the reference signal (clock output) caused by the trigger-delay jitter. The value can be found by subtracting the average value of the clock output from the clock output for each sample taken by the oscilloscope, because the

average of the clock output is the ideal clock output. Mathematically, this can be written as:

$$\Delta V_{REF}[n] = \text{Clock Output}[n] - \frac{1}{n} \sum_{k=1}^n \text{Clock Output}[k], \quad (1)$$

where n = oscilloscope sample number.

However, the trigger-delay jitter is not a function of voltage, but of time. Therefore there must be a method to convert the ΔV_{REF} to the timing error of the reference, Δt_{REF} .

5.2 Finding Δt_{REF}

Δt_{REF} is the time error of the reference signal caused by the trigger jitter delay. So far, the only value known is the ΔV_{REF} . The voltage and time of a signal are related to each other by the slew rate. The slew rate can be defined as the change in voltage divided by the change in time with units of volts per second. Refer to Section 6 for the proper method of finding slew rate.

To convert from the ΔV_{REF} to Δt_{REF} , divide ΔV_{REF} by the slew rate of the clock output.

$$\Delta t_{REF}[n] = \Delta V_{REF}[n]/(\text{clock-output slew rate}) \quad (2)$$

At this point the Δt_{REF} , the trigger-delay jitter of the reference clock is known. Still this gives no immediate information, because the goal is to remove the trigger-delay jitter from the DUT, not the reference. However Δt_{REF} and the trigger-delay jitter added on to the DUT (Δt_{SIGNAL}) are related.

5.3 Finding Δt_{SIGNAL}

There is a clear relationship between Δt_{REF} and Δt_{SIGNAL} . As mentioned earlier, if there are two signals on a sampling head with two inputs, then any trigger-delay jitter on one input must be the same trigger-delay jitter on the second input.

If the reference signal and the DUT signal are on the same sampling head, then their trigger-delay jitter should be the same.

Since Δt_{REF} is the trigger-delay jitter of the reference signal, then Δt_{SIGNAL} , the trigger delay of the DUT signal, should be the same.

$$\Delta t_{SIGNAL}[n] = \Delta t_{REF}[n] \quad (3)$$

Since the oscilloscope operates from voltage values rather than time values, a conversion from Δt_{SIGNAL} back to ΔV_{SIGNAL} is necessary. ΔV_{SIGNAL} is the voltage error on the signal caused by trigger-delay jitter.

5.4 Finding ΔV_{SIGNAL}

ΔV_{SIGNAL} is related to Δt_{SIGNAL} in the same manner that ΔV_{REF} is related to Δt_{REF} , by the slew rate.

$$\Delta V_{SIGNAL}[n] = \Delta t_{SIGNAL}[n] * \text{DUT slew rate}[n] \quad (4)$$

Refer to Section 6 for the proper method of finding the slew rate.

Finally the voltage error caused by the trigger-delay jitter is known. The next step is to remove the error caused by the trigger-delay jitter from the oscilloscope by continuously finding and removing the voltage error caused by the trigger-delay jitter for every trigger event.

5.5 Removing Trigger-Delay Jitter

The above calculations yield ΔV_{SIGNAL} , the voltage error caused by the trigger-delay jitter.

To remove the ΔV_{SIGNAL} simply subtract it off from the DUT's signal. Therefore, DUT signal - ΔV_{SIGNAL} is the DUT signal without any trigger-delay jitter.

Signal Without Trigger-delay jitter = $\text{DUT}_{SIGNAL}[n] - \Delta V_{SIGNAL}[n]$.

5.6 Quick Review

Find the voltage error caused by trigger-delay jitter on the reference (ΔV_{REF}), which has units of volts. Next, divide the error by the slew rate of the reference signal. The slew rate has units of volts per second. The volts from the ΔV_{REF} cancel the volts from the slew rate giving the Δt_{REF} in units of seconds.

The reference signal and DUT signal will be on the same sampling head, $\Delta t_{REF} = \Delta t_{SIGNAL}$. Where Δt_{SIGNAL} is the time error caused by the trigger-delay jitter.

Finally, convert the Δt_{SIGNAL} back to voltage by multiplying it by the DUT signal slew rate. This will yield ΔV_{SIGNAL} in units of volts, which is what the oscilloscope needs. Subtract ΔV_{SIGNAL} from the DUT's output.

6 Finding the Slew Rate

The slew rate can be found with the following technique. This is a crucial step and should be done with care. Display both the reference signal and the DUT signal. Adjust the volts per division and time per division on each until only the rising or falling edge of the clock and data are on the screen. Remove any skew between the channels. Turn averaging on for both channels.

Next, adjust the volts per division and time per division, taking care to insure that the rising or falling edge is not too steep. If they are, then the error becomes more pronounced and can possibly take the value outside of the scope's range. Do not make the signals less than approximately 45° from the center of the oscilloscope, otherwise the internal voltage offsets can create problems.

Delay the data using the pattern generator, do not deskew the oscilloscope, until the data and clock signals fall on top of each other. Adjust the volts per division and time per division until both are directly on top of each other. Refer to Figure 3 for an example.

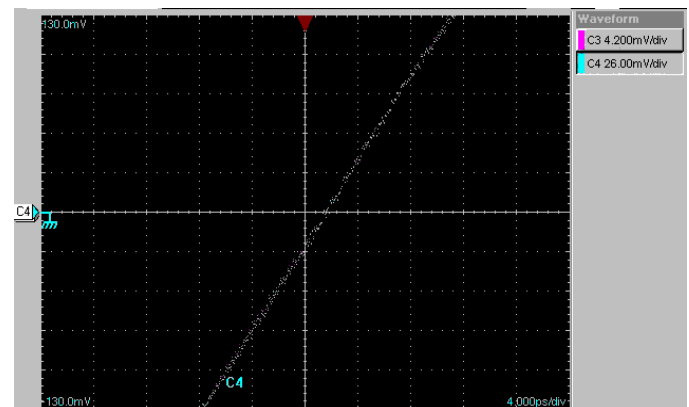

Figure 3. Finding the Slew Rate

C3 and C4 were on the same sampling head. C3 is located directly underneath C4 and therefore not visible.

Record the change in the voltage, divided by the change in time for each signal. This value is the slew rate for each respective signal. Note that in this application the time per division will be the same for both signals, and the volts per division (vertical scale) should suffice as the value of the slew rate.

The Figure 3 measurement was taken using the MAX3971, and the Tektronix CSA8000 oscilloscope. The C3 is the DUT signal, which is 4.2mV/div; and C4 is the clock signal, which is 26mV/div. Both are set at 4ps/div. From this, the calculation for the slew rate is simplified.

Slew Rate for the DUT signal is 4.2mV/div divided by 4ps/div, or 1.05mV/ps. Slew Rate for the clock signal is 26mV/div divided by 3ps/div, or 6.5mV/ps.

Once this measurement is found, turn off averaging and do not adjust the knobs until later on in the measurement. Adjusting anything at this time could affect the values

7 Setup for Removing the Sampling Error

As mentioned previously, the reference and the DUT signal have to be on the same head. Figure 4 shows the setup for the improved method of measuring random jitter.

Connect the data to channel one (C1), and the clock output to channel two (C2). Compiling all the information from the previous sections, the final equation for removing the oscilloscope jitter is:

$$M1 = C1 - \left[\frac{C1SlewRate}{C2SlewRate} \right] (C2 - AVG(C2)) \tag{6}$$

According to the equation:

$$C2 - Avg(C2) = \Delta V_{REF} \tag{7}$$

$$(C2 - Avg(C2)) / C2SlewRate = \Delta t_{REF} \tag{8}$$

where C2SlewRate = slew rate of the clock signal.

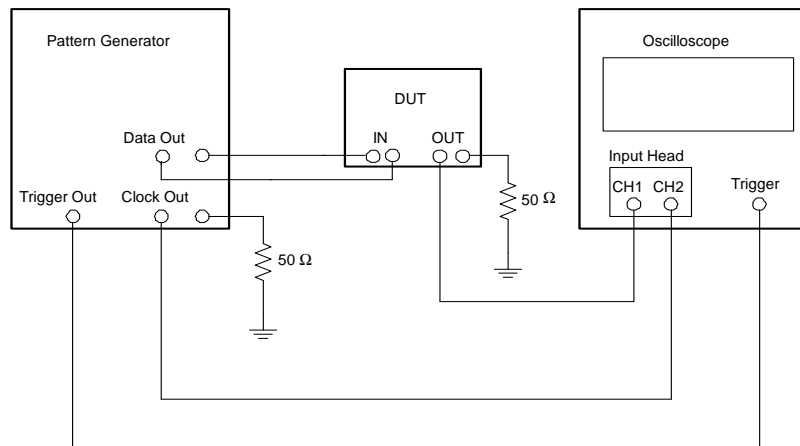

Figure 4. Configuration for Proper Measurement of Random Jitter

$$\Delta t_{\text{SIGNAL}} = \Delta t_{\text{REF}} \quad (9)$$

$$C1\text{SlewRate} * ((C2 - \text{Avg}(C2)) / C2\text{SlewRate}) = \Delta V_{\text{SIGNAL}} \quad (10)$$

where $C1\text{SlewRate}$ = slew rate of data signal.

Finally, the signal without trigger-delay jitter ($M1$) = $C1 - C1\text{SlewRate} * ((C2 - \text{Avg}(C2)) / C2\text{SlewRate})$. (11)

$$\text{Or, } M1 = \text{DUT}_{\text{SIGNAL}} - \Delta V_{\text{SIGNAL}} \quad (12)$$

Measuring the standard deviation at the zero crossing is now not affected by the oscilloscope's trigger-delay jitter.

8 Method for Measuring Random Jitter

The following example explains how to measure random jitter on a Tektronix CSA8000 oscilloscope.

- (1) Choose the data out of the pattern generator to be a one zero pattern.
- (2) Type the M1 function from the previous section into the oscilloscope. Zoom in so there is only the rising or falling edge of the M1 function. Start the horizontal histogram mode of the oscilloscope, and limit the top and bottom level of the histogram to less than a third of a division around the zero crossing to only measure the zero crossing.
- (3) Turn on infinite persistence, and wait for enough hits (approximately 3000) until the sigma value or RMS value starts to converge. Record the RMS time value of the edge. This value is the random jitter of the DUT without trigger-delay jitter caused by the oscilloscope.

Refer to Figures 5 and 6 for the benefits of measuring random jitter using this improved method. Both were measured using the CSA8000.

Figure 5 shows the measurement for the pattern generator done in a traditional fashion. The data out was taken directly from the pattern generator and connected to the oscilloscope. The input level was 500mVpp and the frequency was 10.3GHz.

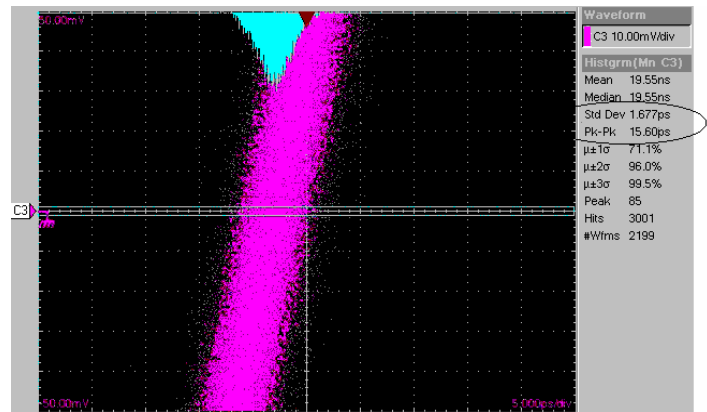

Figure 5. Random Jitter Measured in the Traditional Method

From this oscilloscope reading the random jitter measurement of the pattern generator (ideally zero) is 1.677psrms and 15.60ps peak to peak. This measurement includes the random jitter of the pattern generator as well as trigger random jitter.

Figure 6 shows the exact same measurement, however done with the improved method.

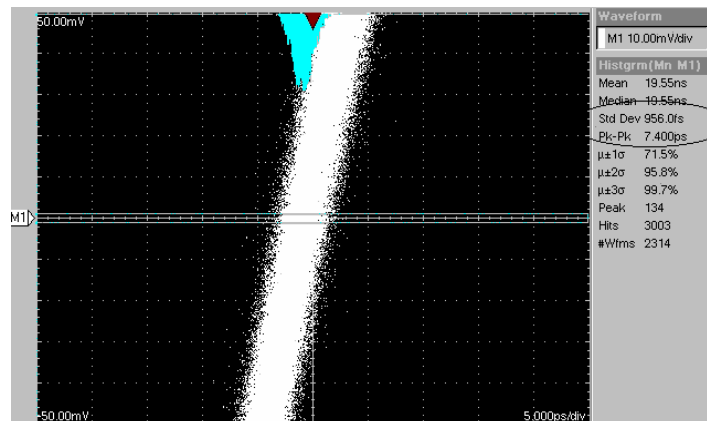

Figure 6. Random Jitter Measured with Improved Method

From this oscilloscope reading the random jitter measurement of the pattern generator is 956.0fsrms and 7.400ps peak to peak. This measurement has the trigger-delay jitter removed.

The trigger-delay jitter for this measurement is the square root of $1.677^2 - 0.956^2$. This value is 1.377psrms, well within specification of the CSA8000. This exercise proves that without using this type of method, the DUT's random jitter measurement will be incorrect, possibly by a factor of 1.377psrms, more than the allowable DUT jitter.