

APPLICATION NOTE 1180

High-Accuracy Current-Sense Amplifier Enables Current Sensing and Current Sharing

Abstract: Current sharing between DC/DC converter modules enables several modules to be paralleled. In recent years, tight tolerances for current sharing have made discrete current-sense circuit designs a formidable challenge. This application note describes a low-cost, space-saving and accurate current sensing and sharing scheme using MAX4372.

Current sharing between DC/DC converter modules is a very important system parameter in ensuring reliable operation. In recent years, the tolerance for current sharing has been tightened to 10% of the rated output current, resulting in a challenge in designing a discrete current-sense circuit, as shown in **Figure 1**, particularly in high-output-current power supplies. This is because a small-value current-sense resistance (less than or equal to $2\text{m}\Omega$) is needed to minimize power dissipation, yielding a small current-to-voltage conversion, meaning $\leq 2\text{ mV/A}$. This makes it very difficult for the traditional discrete current-sense amplifier to meet the total tolerance requirement due to the op amp (U1), the input offset voltage, and external component tolerances. An example of an op-amp-based circuit for a 20A output current application is shown in Figure 1. Assume that $R1 = 2\text{m}\Omega$ and U1 has a maximum-input offset voltage of 3mV. Because the 2mV drop across R1 represents 1A output current, the 3mV offset voltage in the worst case represents a 7.5% error (due to offset only), which is often unacceptable. Low-input offset-voltage op amps together with precision resistors ($\pm 0.1\%$ tolerance) reduce the error, but the cost increases significantly.

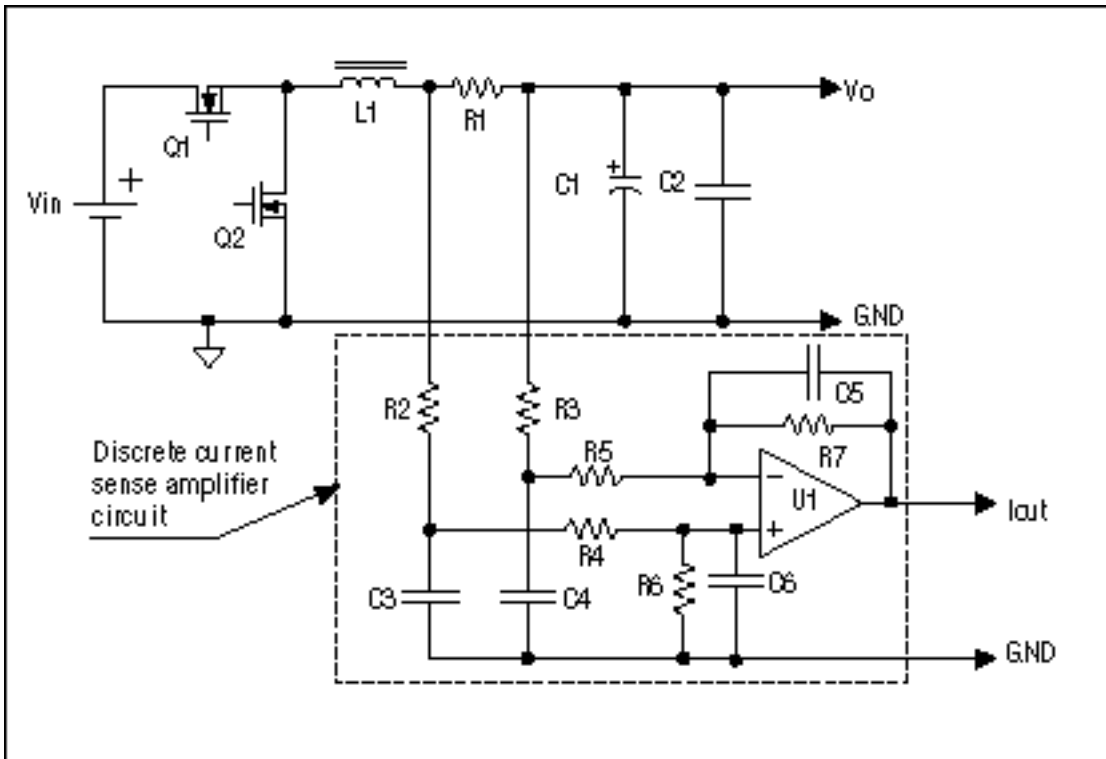

Figure 1. Schematic of a typical discrete current-sense amplifier.

Another issue associated with the discrete current-sense circuit is added manufacturing for assembling the external components. A precision, low-cost, space-saving, current-sense IC is needed to replace the discrete circuit.

The MAX4372, in a tiny SOT23-5 package, provides a low-cost, space-saving, and precision solution to high side and high current sense. Offered in three gain versions (20V/V, 50V/V, and 50V/V), this device operates from a single +2.7V to +28V supply and consumes only 30 μ A. Guaranteed by design and trimming of input offset voltage and gain, the MAX4372 provides 0.18% full-scale accuracy with 100mV V_{sense} input. This is equivalent to only 0.18mV input offset voltage, assuming that the error is due solely to the input offset voltage. If the MAX4372 is applied to the previous example, the total tolerance is reduced to just 0.45% (0.18mV/40mV). The user can set the full-scale current reading by choosing the device (T, F, or H) with the desired voltage gain and selecting the appropriate external sense resistor. This capability offers a high level of integration and flexibility, resulting in a simple and compact current-sense solution. The MAX4173 offers higher-bandwidth current-sense solutions. **Figure 2** shows a typical circuit for a 20A current-sense application.

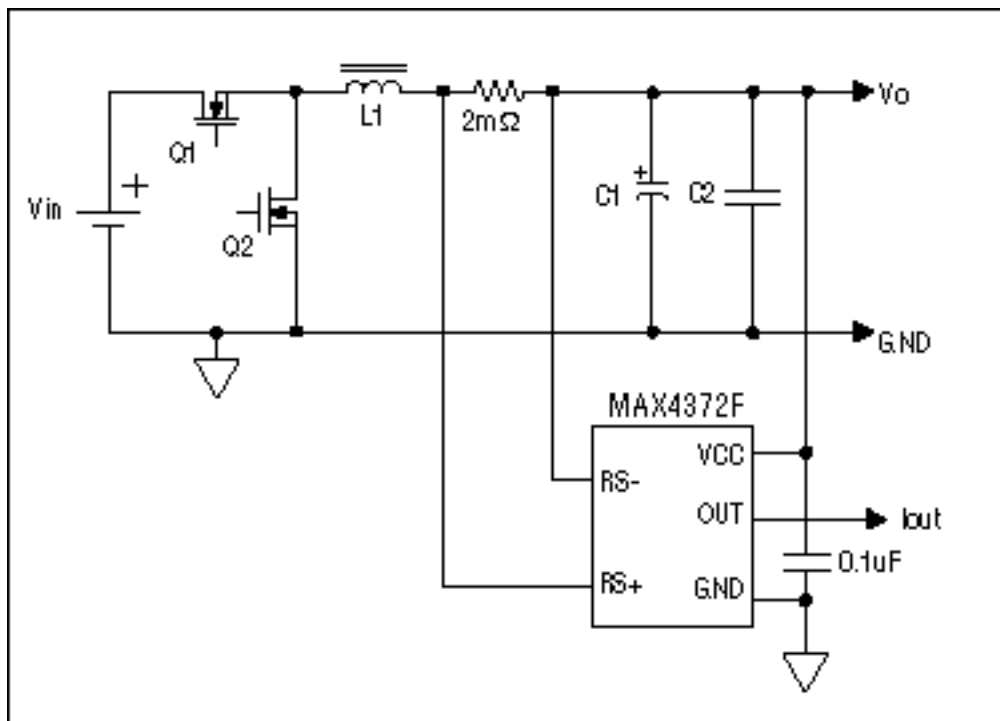

Figure 2. A typical 20A current-sense application using the MAX4372F.

Application Note 1180: <http://www.maxim-ic.com/an1180>

More Information

For technical questions and support: <http://www.maxim-ic.com/support>

For samples: <http://www.maxim-ic.com/samples>

Other questions and comments: <http://www.maxim-ic.com/contact>

Related Parts

MAX4372: [QuickView](#) -- [Full \(PDF\) Data Sheet](#)

AN1180, AN 1180, APP1180, Appnote1180, Appnote 1180

Copyright © by Maxim Integrated Products

Additional legal notices: <http://www.maxim-ic.com/legal>