



APPLICATION NOTE 1165

## Interfacing the MAX5195 High-Speed DAC to High-Speed FPGAs

*Abstract: The following applications brief provides two practical solutions, enabling users of the MAX5195 high-speed digital-to-analog converter (DAC) to design a reliable resistor network for interface this LVPECL-based high-speed DAC to off-the-shelf FPGAs.*

The MAX5195 is a 14-bit, 260Msps high-speed digital-to-analog converter (DAC). Its data interface is compatible with high-speed low-voltage positive emitter-coupled logic (LVPECL) signals. Matched-transmission-line capabilities enable the interface to handle very high speed data signals, and its differential digital-signal inputs minimize the effects of noise originating from a printed circuit board (PCB).

High-speed FPGAs such as the Xilinx Virtex series and Altera Apex series have LVPECL-compatible outputs suitable for driving the MAX5195. The following discussion should help you achieve optimum operation while interfacing these high-speed logic devices to the MAX5195.

### Xilinx Virtex Interface

The LVPECL outputs of Xilinx's Virtex family of FPGAs require an external resistor network to transform their output voltage and impedance levels into LVPECL-compliant signals. Such output-termination networks yield logic levels (low and high) whose DC offset differs approximately -300mV from those of true LVPECL levels. Unfortunately for the DAC, such signals exceed the low-voltage limit for its LVPECL inputs.

To adapt their quasi-LVPECL outputs to true LVPECL output levels, Xilinx suggests a simple modification to the network (**Figure 1**): add two resistors for each differential connection. The suggested network is shown below, coupling a single differential pair of output signals from a Virtex FPGA to the MAX5195. The resistors help to offset the output voltages by +300mV, thereby centering those voltages about the true LVPECL levels. The resistors also eliminate violations of input range on the MAX5195's low-voltage side.

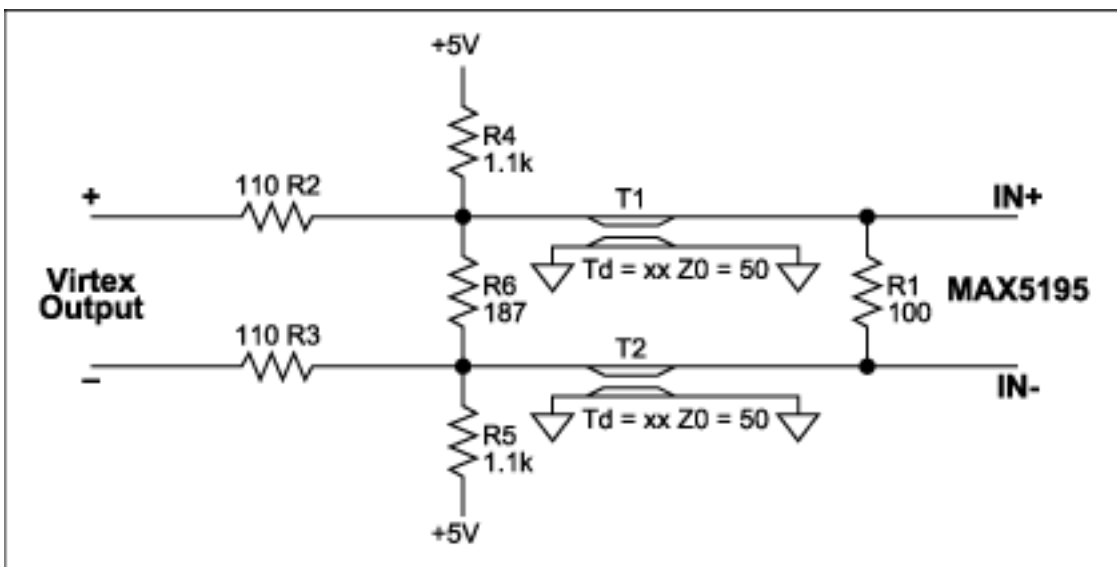

Figure 1. Xilinx's Virtex family resistor network to drive the MAX5195.

Resistors R2-R6 should be placed at the Virtex FPGA source pins, forming a 100Ω differential source impedance. Two 50Ω transmission lines connect this source to the remote MAX5195 input pins, and R1 connects across the MAX5195 LVPECL inputs to provide a 100Ω differential load impedance. Using the following resistor values, you can replicate that network for each of the 14 LVPECL data pairs.

#### Resistor Values

R1	100Ω
R2, R3	110Ω
R4, R5	1.1kΩ
R6	187Ω

The network yields a 100Ω matched-impedance system (source, line, and termination) that maintains excellent logic-signal fidelity. Because Virtex drivers exhibit fast transition times, the trace lengths interconnecting the resistor networks should be less than 1cm long (0.39 inches). Logic levels at the receiver inputs are  $V_{OH} = 2.32V$  and  $V_{OL} = 1.62V$ , which places them in the middle of the LVPECL input range.

## Altera Apex Interface

As shown in **Figure 2**, LVPECL outputs of the Altera Apex series of FPGAs also require an external resistor network to transform impedance and voltage levels into LVPECL-compliant signals. Again, the network couples one differential pair of output signals from an Apex FPGA to the MAX5195.

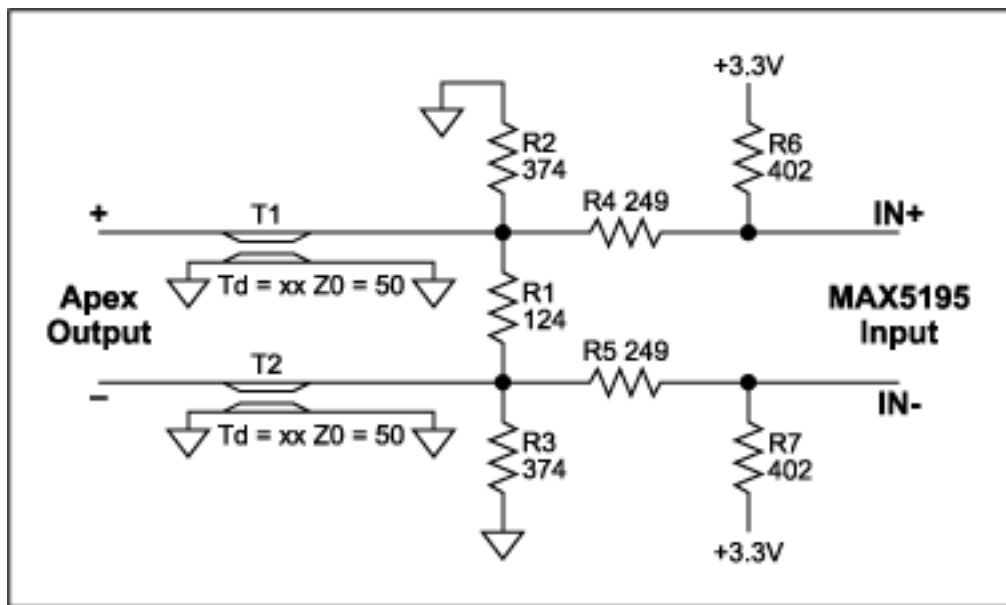

Figure 2. Apex Family resistor network to drive the MAX5195.

Resistors R1-R7 should be placed at the MAX5195 input pins. The network then forms a 100Ω termination resistance for two 50Ω transmission lines from the FPGA outputs. Again, fast transition times at the Apex driver outputs require that trace lengths interconnecting the resistor network and MAX5195 inputs should be less than 1cm long (0.39 inches).

#### Resistor Values

R1	124Ω
R2, R3	374Ω
R4, R5	249Ω
R6	402Ω

Logic levels at the receiver inputs are  $V_{OH} = 2.33\text{ V}$  and  $V_{OL} = 1.55\text{ V}$ , which places them within the LVPECL input range.

## Summary

The MAX5195 DAC includes a high-speed, low-noise, differential LVPECL interface. Modern high-speed FPGAs are capable of driving the MAX5195 very effectively, but they typically require a matching resistor network to optimally drive LVPECL loads. With an appropriate network, the interface delivers speed and low-noise capability as well.

---

Application Note 1165: <http://www.maxim-ic.com/an1165>

### More Information

For technical questions and support: <http://www.maxim-ic.com/support>

For samples: <http://www.maxim-ic.com/samples>

Other questions and comments: <http://www.maxim-ic.com/contact>

### Related Parts

MAX5195: [QuickView](#) -- [Full \(PDF\) Data Sheet](#)

AN1165, AN 1165, APP1165, Appnote1165, Appnote 1165

Copyright © by Maxim Integrated Products

Additional legal notices: <http://www.maxim-ic.com/legal>