

APPLICATION NOTE 1147

Simple Current Source Determines the MAX1802 Auxiliary Controller Switching Frequency

The MAX1802 is a multiple output power supply that can offer a complete compact solution for powering digital still cameras, video cameras and other handheld devices such as PDAs. It has two step-down DC-DC converters and three step-up auxiliary controllers. The three auxiliary controllers operate in the voltage-control PWM mode with a fixed frequency. An internal linear regulator powers the VL output, from the battery input V_{DDM} if the core power input V_{DDC} is less than 2.4V. Once V_{DDC} rises above 2.4V, the linear regulator turns off and an internal switch turns on to connect VL to V_{DDC} . This helps the MAX1802 to start-up since VL is used to power internal circuitry and the core is typically powered from the MAIN output (see "[MAX1802.pdf](#)" and "[MAX1802Evkit.pdf](#)"). The MAX1802 uses a sawtooth waveform at the OSC pin, generated by an external timing resistor and capacitor powered from VL, to govern the internal timing.

In some applications it is more efficient to power the core directly from the battery. In these applications VL will vary with the input battery voltage. The oscillator frequency is constant while VL is constant (**Figure 1**). A changing switching frequency will make it difficult to choose external components for optimum performance and efficiency for a given application. This can be resolved by using an external discrete current source in place of the external timing resistor.

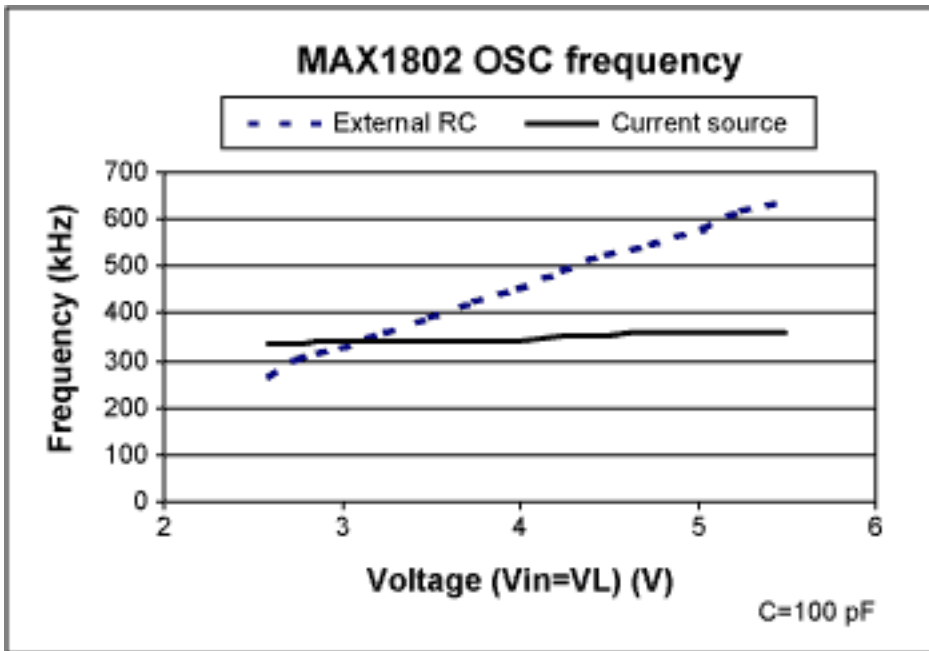

Figure 1. MAX1802 oscillator frequency versus voltage.

Figure 2 shows an application circuit to power a PDA using the MAX1802 with a simple current source to set the switching frequency. The current source consists of two matched transistors P1 and P2 (Central Semiconductor's CMPT3906 transistors) and resistor R1.

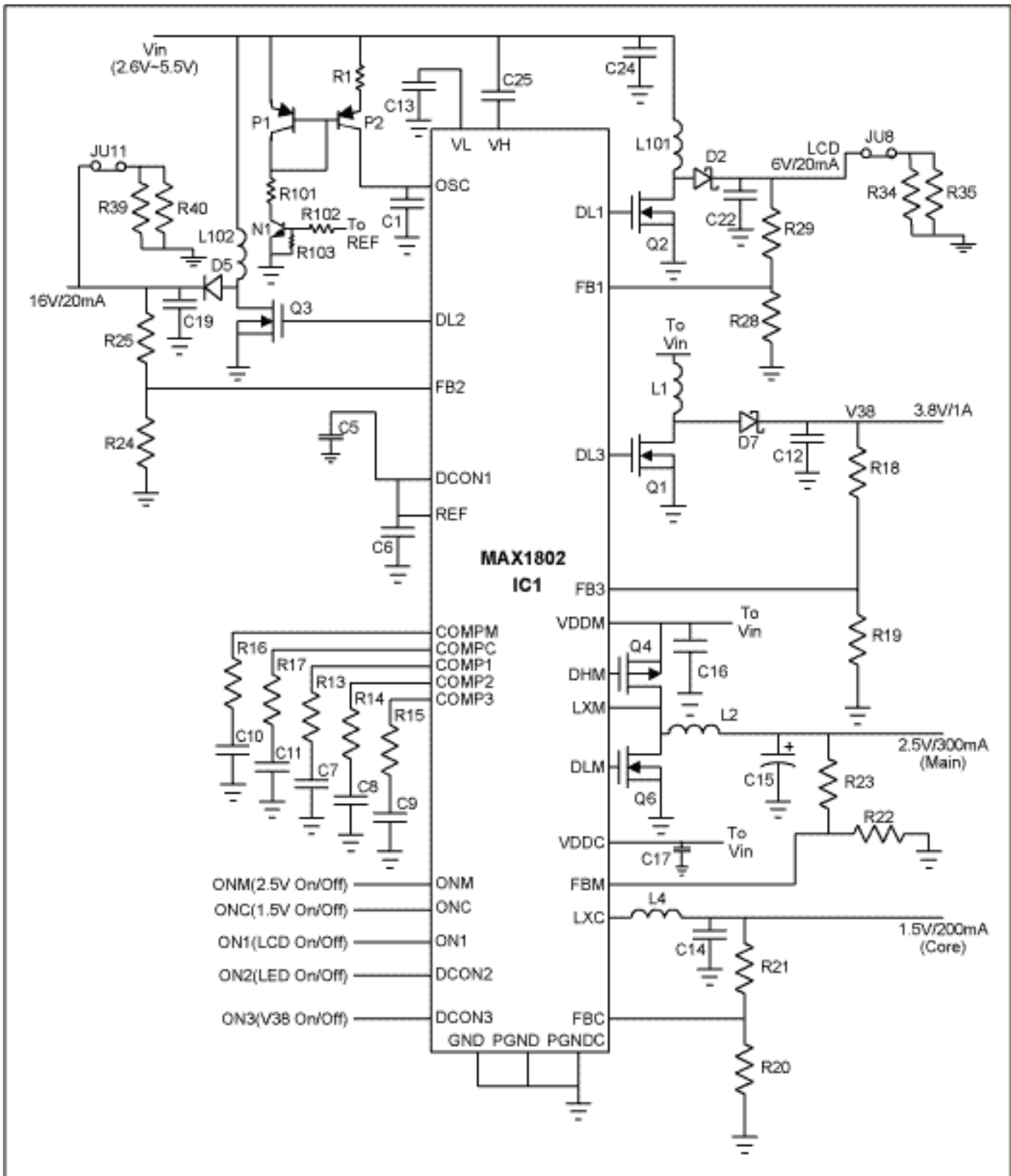

Figure 2. The MAX1802 circuit using discrete current source to determine oscillator frequency.

The transistor N1 (Central Semiconductor's CMPT3904) is used to ensure the current source does not draw any current when the MAX1802 is shutdown. Note that the 3.8V output is not regulated above 4V inputs but that was acceptable in this particular application since this was used in conjunction with a linear post regulator (not shown) in the final system. This circuit operates with a switching frequency of 340kHz. **Figure 3** gives the efficiency for the complete power supply system. The input voltage varies from 2.6V to 5.5V to cover the use of Li+ battery or an adapter as input to the MAX1802. As can be seen from Figure 3 this circuit using the MAX1802 is an efficient and compact solution for this application.

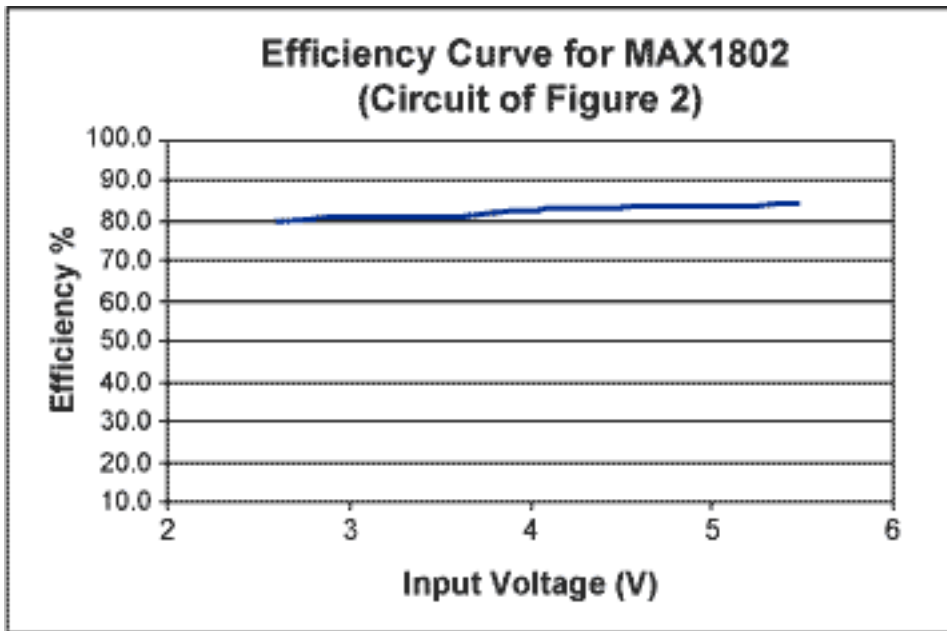

Figure 3. Efficiency curve for circuit of Figure 1.

Application Note 1147: <http://www.maxim-ic.com/an1147>

More Information

For technical questions and support: <http://www.maxim-ic.com/support>

For samples: <http://www.maxim-ic.com/samples>

Other questions and comments: <http://www.maxim-ic.com/contact>

Related Parts

MAX1802: [QuickView](#) -- [Full \(PDF\) Data Sheet](#) -- [Free Samples](#)

AN1147, AN 1147, APP1147, Appnote1147, Appnote 1147

Copyright © by Maxim Integrated Products

Additional legal notices: <http://www.maxim-ic.com/legal>