

APPLICATION NOTE 1146

Adding Panel LED Intensity Control to MAX6952 and MAX6953 5x7 Matrix LED Drivers

This application note discusses techniques to change the intensity of all the LED digits of a display at once (panel intensity control) driven by the MAX6952 or MAX6953 5x7 LED matrix drivers. This control is additional to the digit-by-digit adjustment the drivers offer already. The note includes a calculator in the form of an Excel spreadsheet that may be downloaded to assist design.

This application note discusses a technique for adding panel LED intensity control to the MAX6952 and MAX6953 4-wire and 2-wire serial-interfaced LED display drivers. Each LED driver controls either four monochrome, or two bicolor 5 x 7 matrix LED digits. Multiple drivers can be used together to form a message display.

These display drivers already have 16-step individual digit current control. The additional control discussed here adds a master intensity control that reduces all the individual digit currents at once, in 4, 8, or 16 steps. This can be used to adjust for ambient lighting conditions, for instance.

A single external resistor R_{ISET} controls the peak segment current for all the segments. R_{ISET} sinks a current from the driver's internal voltage reference, and this small current is mirrored internally to set the peak segment current of up to 40mA. The peak segment current can be controlled on the fly by adjusting the effective value of R_{ISET} . Adjusting R_{ISET} adjusts the peak segment current of all the drivers at once, and therefore operates as a global intensity control. A panel intensity control can be built by adjusting R_{ISET} at the same time, to the same value, for all the drivers in a display panel.

Global intensity control can be achieved by replacing the fixed R_{ISET} resistor with a digital resistor, such as the 32-step MAX5160. If fewer steps are required, and spare GPIO ports are available, then these spare ports can be used to directly control the full-scale segment current. The ports drive discrete resistors to build a simple R-2R-4R type DAC directly at the R_{ISET} pin. The design software is an [Excel spreadsheet](#) which calculates the resistor values used for a 2-bit DAC (resistors RA and RB), for a 3-bit DAC (resistors RA, RB, and RC), and for a 4-bit DAC (resistors RA, RB, RC, and RD). These DACs provide 4, 8, and 16 steps of intensity control respectively (**Figure 1**). Each driver in a panel requires a separate resistor DAC; multiple ISET pins can be driven by one DAC. However, multiple DACs (and therefore, multiple drivers) can be controlled by one set of GPIO ports, because the current sunk into the port by each resistor is small.

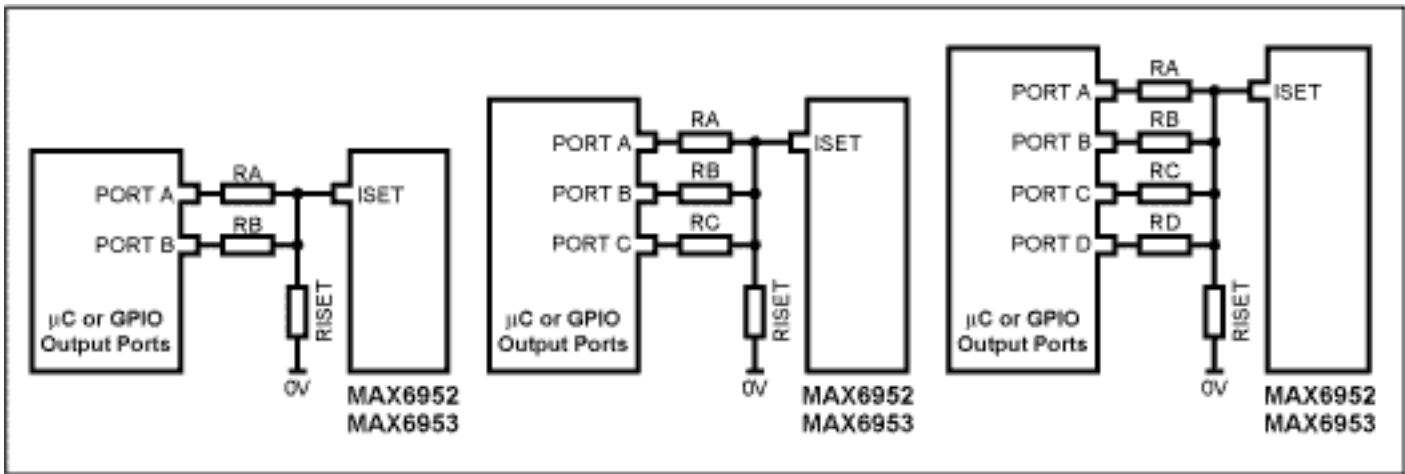

Figure 1. Adding two, three, or four extra resistors to external GPIO ports to build a global intensity control DAC.

The DAC ports should be switched between a logic low output for a DAC code of 0, and high impedance for a DAC code of 1. Open-drain port outputs achieve this logic automatically. Standard microcontroller GPIO ports with push-pull outputs can be made high impedance condition by switching the port's configuration to logic input mode.

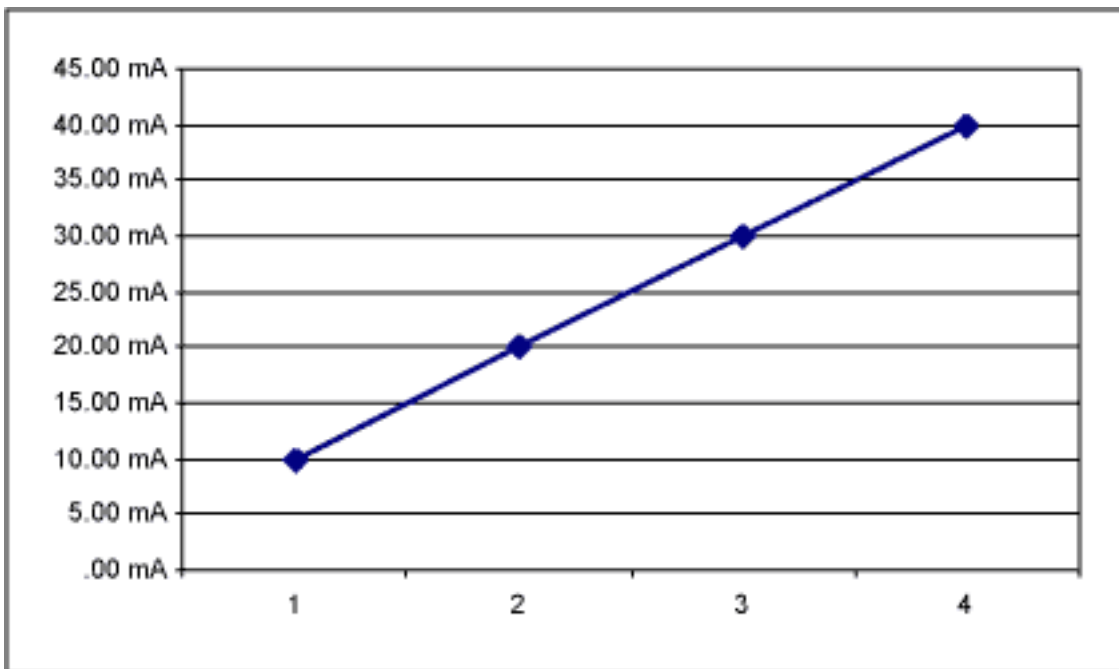

Figure 2. Screenshot of the 2-bit Excel spreadsheet.

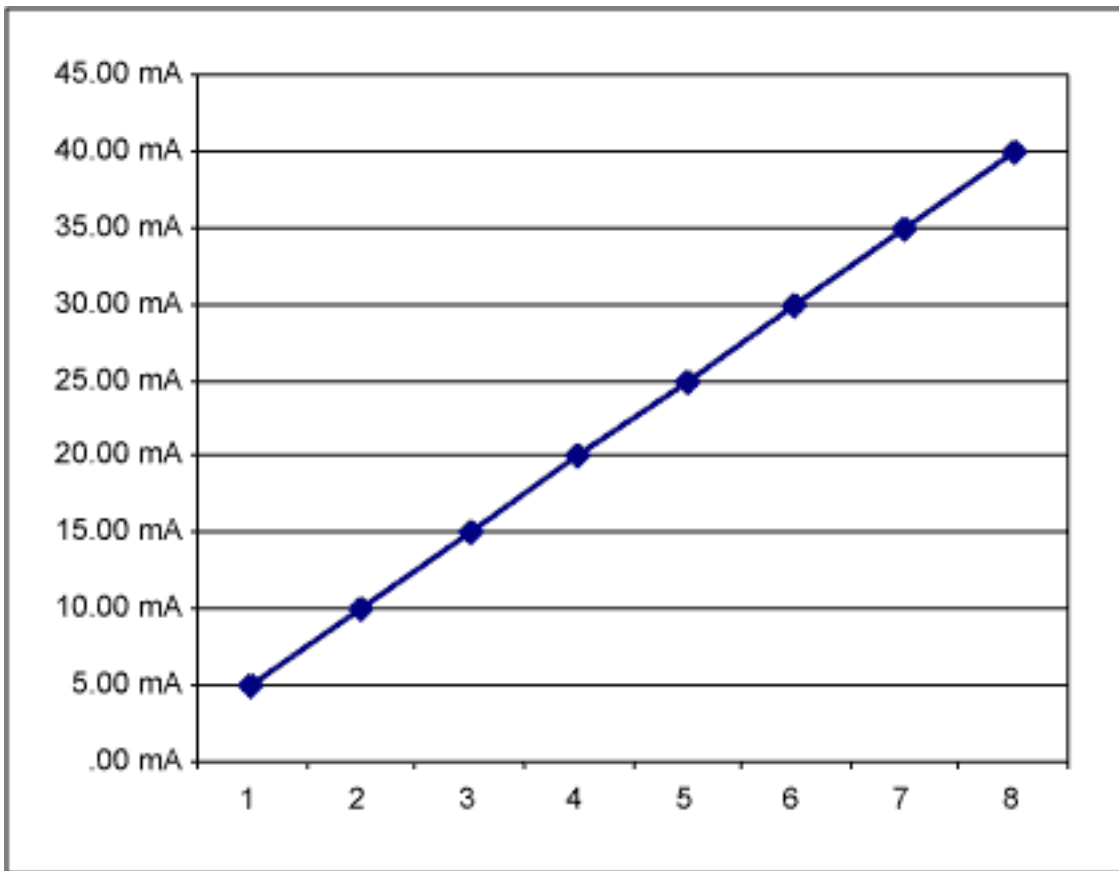

Figure 3. Screenshot of the 3-bit Excel spreadsheet.

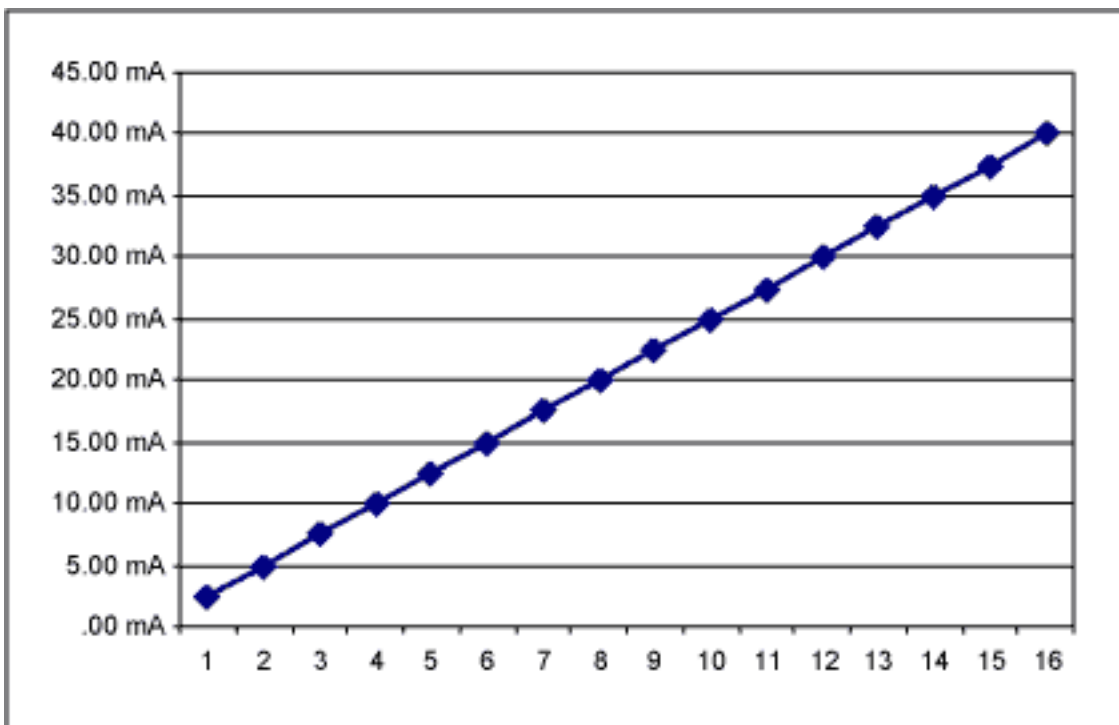

Figure 4. Screenshot of the 4-bit Excel spreadsheet.

Application Note 1146: <http://www.maxim-ic.com/an1146>

More Information

For technical questions and support: <http://www.maxim-ic.com/support>

For samples: <http://www.maxim-ic.com/samples>

Other questions and comments: <http://www.maxim-ic.com/contact>

Related Parts

MAX6952: [QuickView](#) -- [Full \(PDF\) Data Sheet](#) -- [Free Samples](#)

MAX6953: [QuickView](#) -- [Full \(PDF\) Data Sheet](#) -- [Free Samples](#)

AN1146, AN 1146, APP1146, Appnote1146, Appnote 1146

Copyright © 2005 by Maxim Integrated Products

Additional legal notices: <http://www.maxim-ic.com/legal>