



APPLICATION NOTE 1135

Small Capacitor Improves Efficiency in High-Power CPU Supply

For the high- V_{IN} DC/DC buck converters that supply high current in notebook PCs, high efficiency is very important for the purpose of extending battery life and minimizing temperature rise. A low-dissipation synchronous rectifier with external MOSFET also supports this purpose.

Synchronous rectifiers require special attention, however. Bad designs allow shoot-through current when the high-side and low-side MOSFETs are on simultaneously. Some engineers believe enough dead time (between turn-off of one MOSFET and turn-on of the other) can eliminate this problem, but dead time is not sufficient in some applications.

Figure 1 illustrates a stepdown power supply in which a stepdown controller (MAX1718) provides the CPU-core supply. Recent CPU cores require a very low supply rail (1V to 2V) with more than 20A of current. The input voltage range, on the other hand, is high (7V to 20V). These circumstances force a very low duty cycle for the high-side MOSFET (Q1).

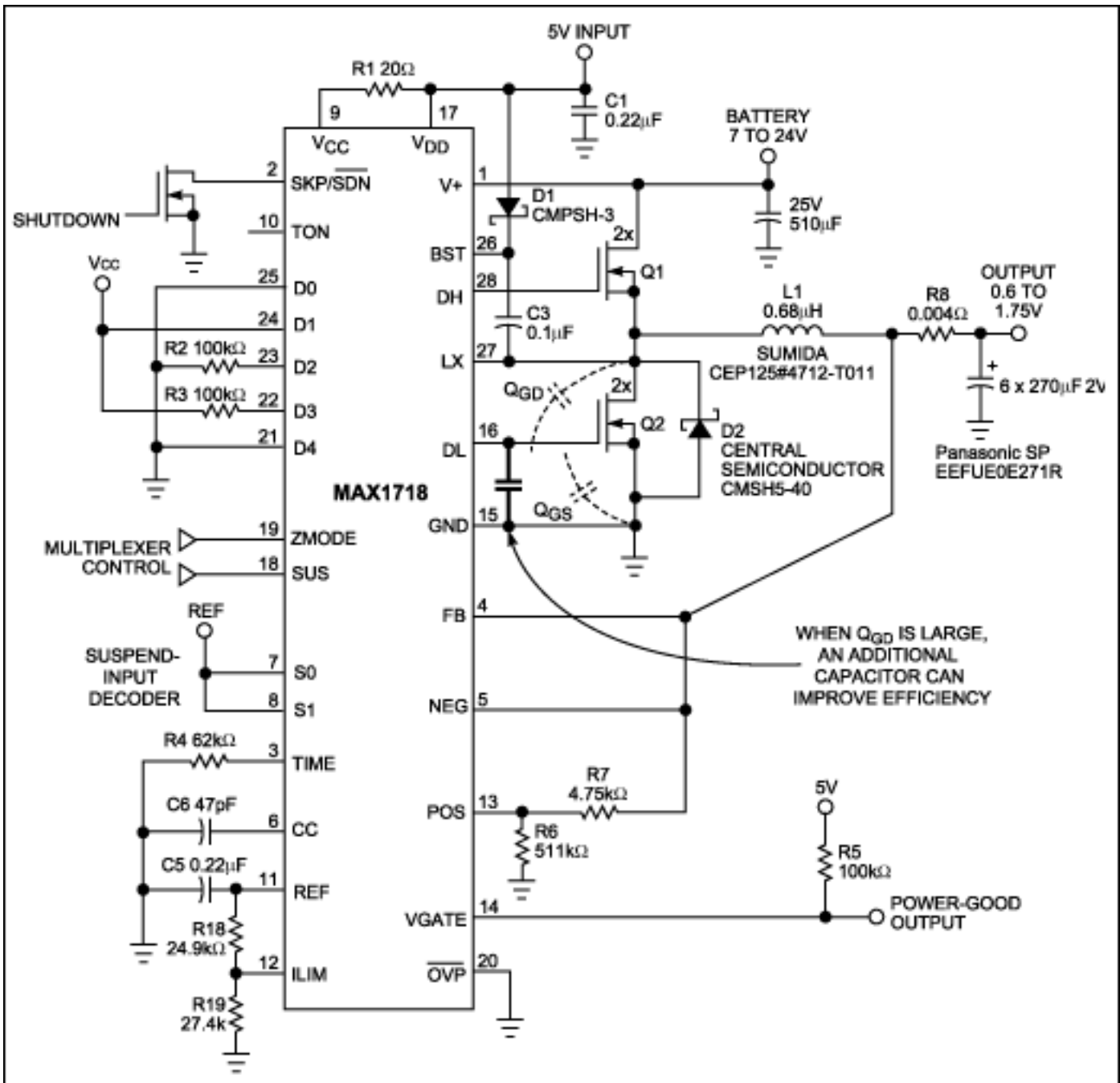

Figure 1. This IC (MAX1718) forms a CPU-core power supply.

Obtaining high efficiency with a low duty cycle requires different types of MOSFET for the high-side and low-side devices (Q1 and Q2). Q1 requires very high switching speed even if its on-resistance is relatively high, but Q2 requires very low on-resistance even if its switching speed is relatively slow. That combination allows no possibility of shoot-through current when Q2 turns on, because Q1's fast turn-off occurs first. Because the Q2 turn-off is slow, however, you must allow enough dead time before Q1 turns on. The MAX1718 solves this problem by monitoring Q2's gate voltage, thereby ensuring that Q1 turns on only after Q2 is completely off.

We now pay attention to a third condition leading to the possibility of shoot-through current: a rise in Q2 gate voltage when Q1 turns on, due to high dV/dt at LX. That condition can appear even with sufficient dead time, because it involves high current flow into DL through C2's gate-drain capacitance. The MAX1718's large current-sink capability at DL solves this problem.

Sometimes, however, if Q2's gate-drain capacitance is large or the trace from DL is long, or both, the shoot-through current can be eliminated by adding a capacitor of several thousand picofarads between the gate and source of Q2 (Figure 2a). Better efficiency is the result (Figure 3). Note that too large a gate-source capacitor increases the driver loss.

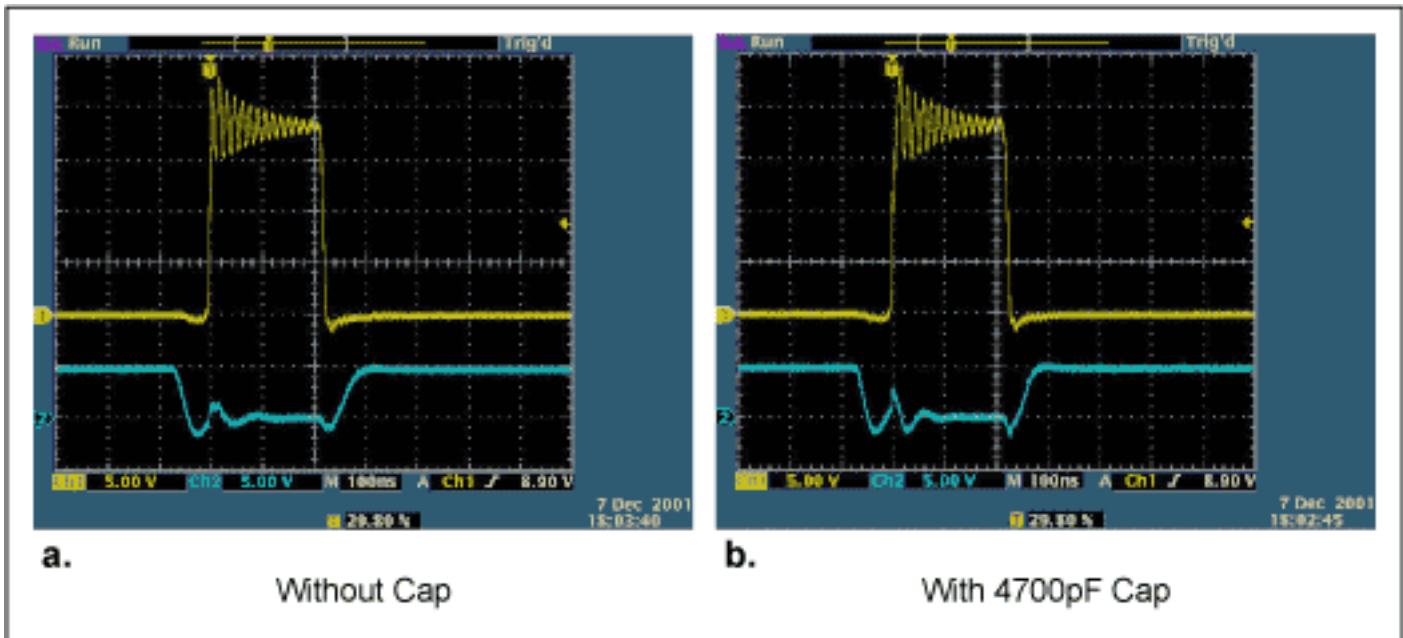

Figure 2. DL and LX waveforms without cap (a) and with cap (b).

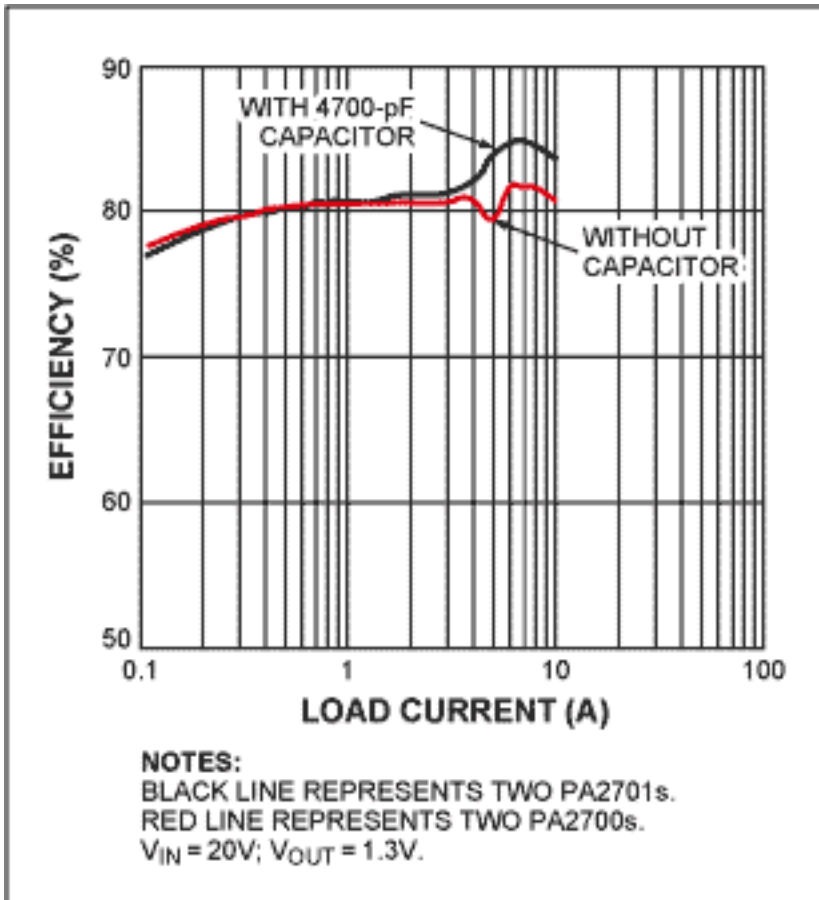

Figure 3. Adding a capacitor in Figure 1 (see text) improves the efficiency as shown.

A similar version of this article appeared in the April 4, 2002 issue of *EDN* magazine.

Application Note 1135: <http://www.maxim-ic.com/an1135>

More Information

For technical questions and support: <http://www.maxim-ic.com/support>

For samples: <http://www.maxim-ic.com/samples>

Other questions and comments: <http://www.maxim-ic.com/contact>

Related Parts

MAX1718: [QuickView](#) -- [Full \(PDF\) Data Sheet](#) -- [Free Samples](#)

AN1135, AN 1135, APP1135, Appnote1135, Appnote 1135

Copyright © by Maxim Integrated Products

Additional legal notices: <http://www.maxim-ic.com/legal>