

APPLICATION NOTE 1134

Uninterruptible Power Supply for USB Devices

Portable systems often include circuitry that derives power from an external source such as the universal serial bus (USB). When the system is disconnected from the USB supply, a battery takes over and supplies power through a DC/DC converter. A diode-OR connection (**Figure 1**) offers the easiest way to ensure that the supply voltage doesn't sag during this switchover to the battery. The diode's forward voltage drop, however, can reduce battery life and efficiency.

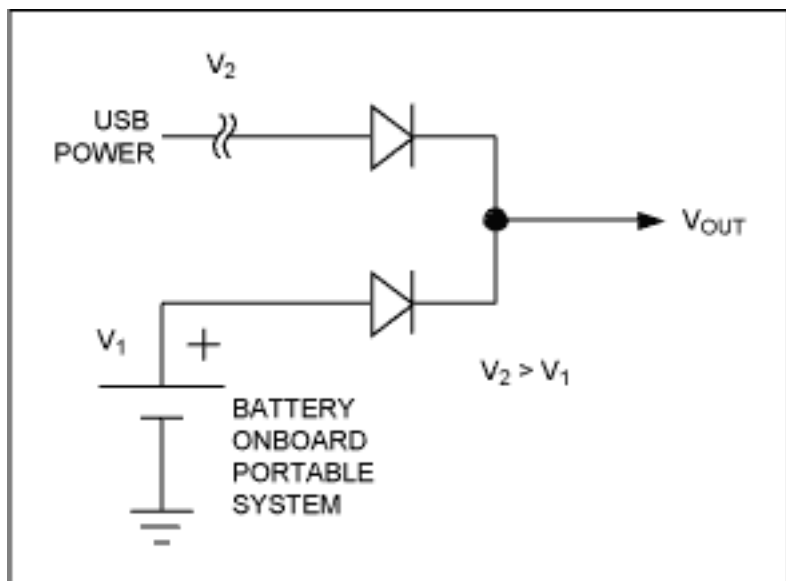

Figure 1. A simple diode-OR connection links two power sources to the load (V_{OUT} is determined by the greater of V_1 or V_2).

The single-cell boost-converter circuit with external PFET (**Figure 2**) is an improvement over the diode-OR connection. The PFET (Q1) coupled with U1's internal gain block forms a linear regulator, and the USB power supply is diode-OR connected to Q1's source. The boost-converter's output is set to 3.4V, allowing the drain of Q1 to regulate to 3.3V. This configuration produces negligible loss across Q1.

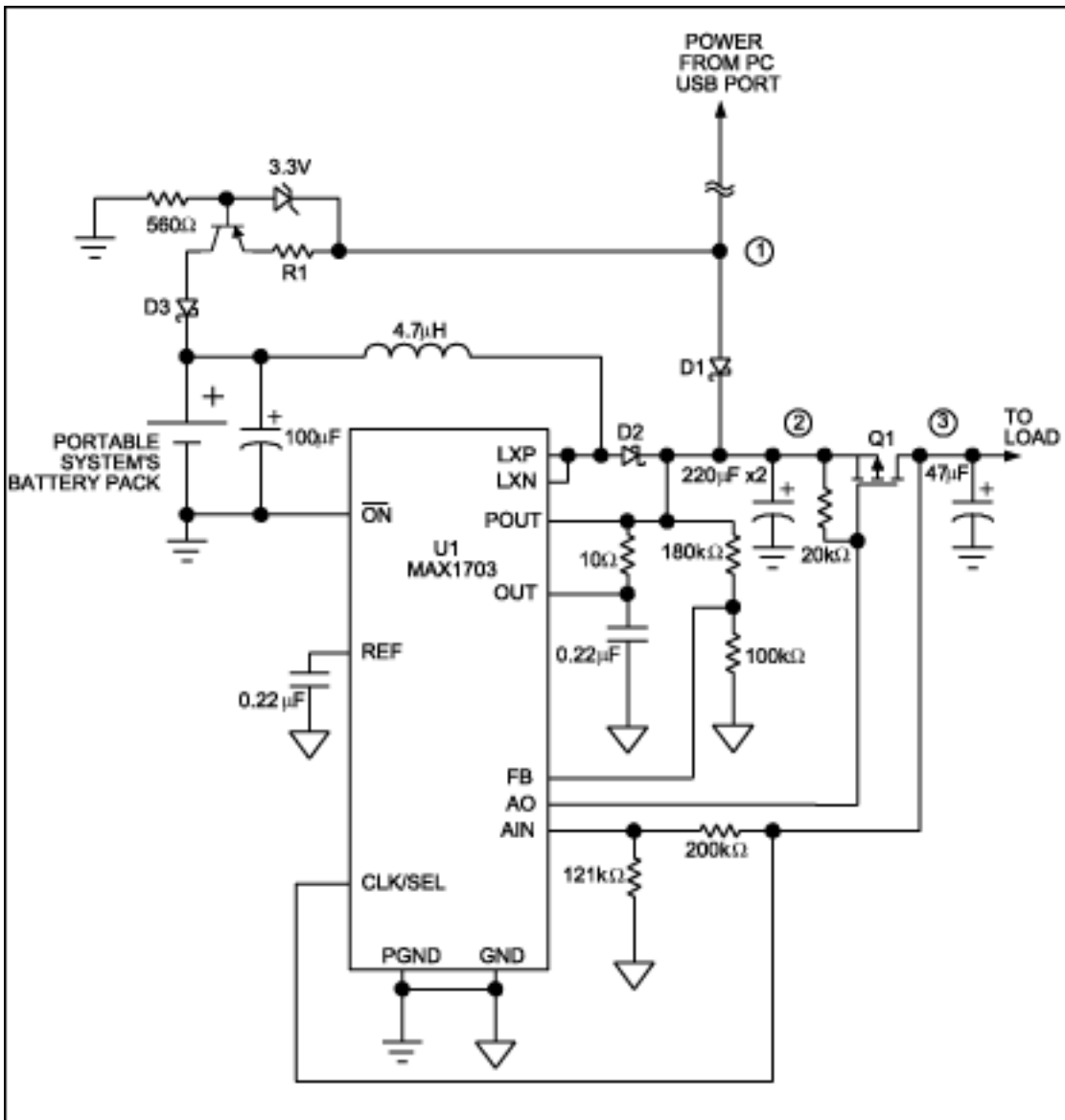

Figure 2. This boost converter circuit provides uninterruptible power with maximum efficiency and maximum battery life.

The bus-supply voltage available to USB devices ranges from 4.4V to 5.25V. When connected, it forward-biases D1 and causes the boost converter to idle. The boost converter continues to idle as long as its output remains above the 3.4V regulation point. The bus supply services the load and activates the current source to charge the battery. Adjusting R1 allows you to set the current-source output to charge the NiMH cells at one-tenth the battery's capacity.

Disconnecting the circuit from the USB causes the boost converter to cease idling and supply power to the load via the battery. **Figure 3** shows that load current is not interrupted during a switchover from USB to battery.

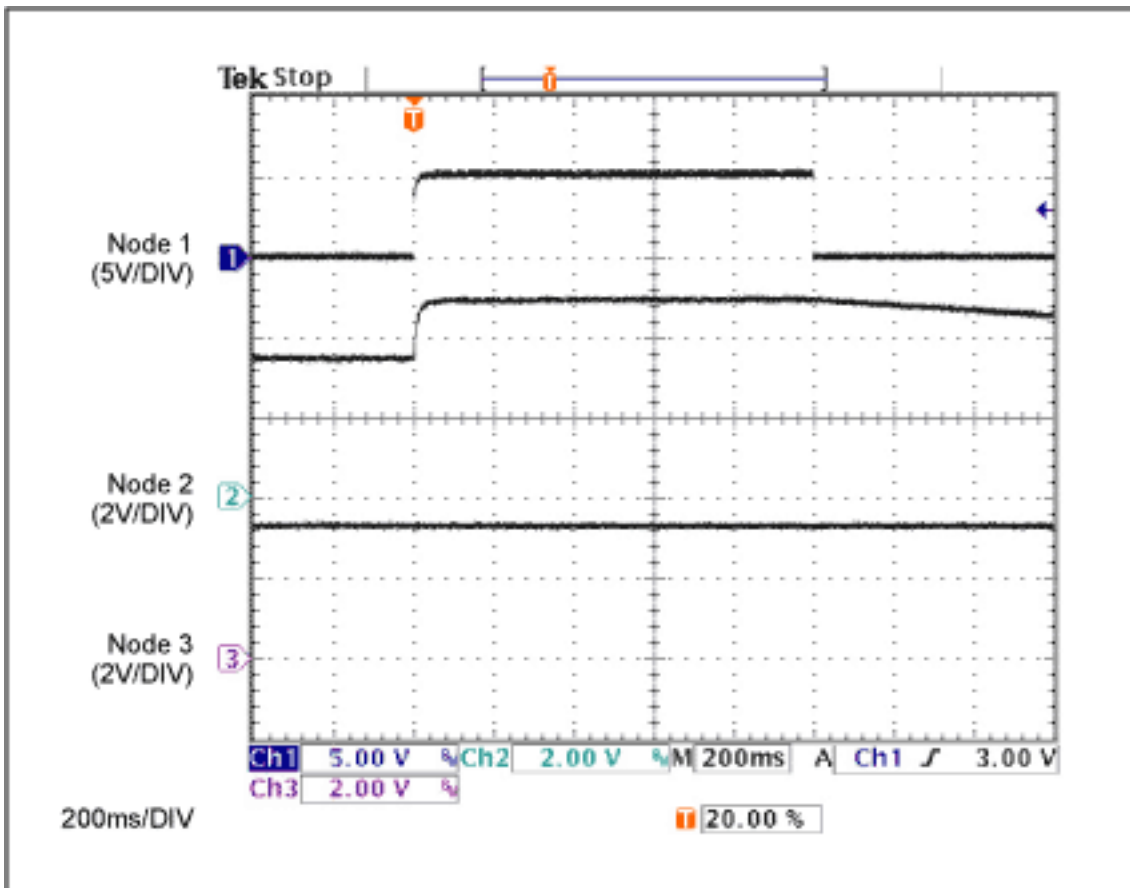

Figure 3. These waveforms from Figure 2 (see numbered nodes) show that a switch from battery to USB voltage has no effect on the load voltage (bottom trace).

A similar version of this article appeared in the April 11, 2002 issue of *EDN* magazine.

Application Note 1134: <http://www.maxim-ic.com/an1134>

More Information

For technical questions and support: <http://www.maxim-ic.com/support>

For samples: <http://www.maxim-ic.com/samples>

Other questions and comments: <http://www.maxim-ic.com/contact>

Related Parts

MAX1703: [QuickView](#) -- [Full \(PDF\) Data Sheet](#) -- [Free Samples](#)

AN1134, AN 1134, APP1134, Appnote1134, Appnote 1134

Copyright © 2005 by Maxim Integrated Products

Additional legal notices: <http://www.maxim-ic.com/legal>