

APPLICATION NOTE 1121

Using Ceramic Output Capacitors with the MAX1734 Voltage-Mode Buck Converter

Abstract: The MAX1734 voltage-mode buck DC-DC converter was design to work with medium ESR tantalum capacitors; however, by slightly changing the feedback scheme, small, low-ESR ceramic capacitors may be used. A schematic, design equations, and load-transient response waveforms are provided.

Many stepdown (buck) DC-DC controller ICs incorporate a voltage-mode control algorithm. As a result (for stable operation in continuous-conduction mode), the resulting application circuit's output capacitor is normally a high-ESR tantalum type. The circuit of **Figure 1**, however, allows use of an inexpensive ceramic output capacitor. To remove the effects of phase lag in the feedback loop, feedback is derived from the LX pin instead of the output.

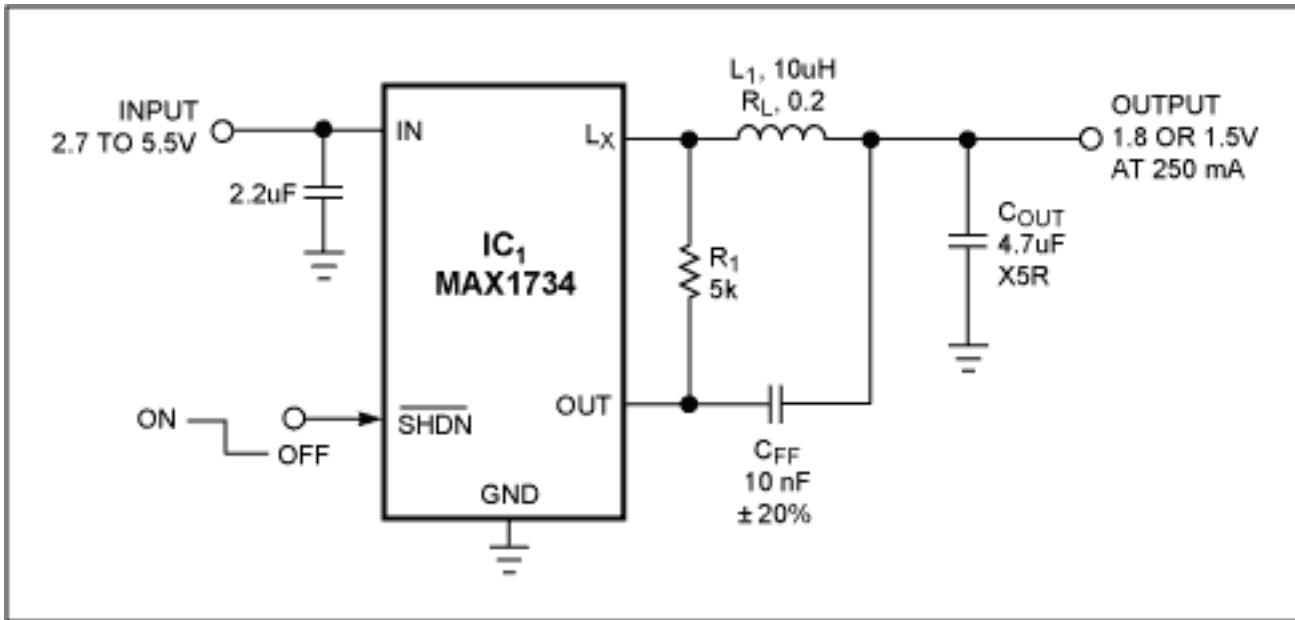

Figure 1. In this simple application circuit, a stepdown DC-DC converter operates with a ceramic output capacitor.

A ceramic-capacitor circuit offers several benefits over the standard application circuit. First, ceramic capacitors are more readily available than tantalum types. Second, (see **Figure 2**) they cause less output ripple (<5mV_{pp} vs. >20mV_{pp}), and less load-transient overshoot (<50mV_{pp} vs. >100mV_{pp}). IC1¹ needs 20mV_{pp} or more at the OUT pin for stable operation under load. To meet this requirement, first calculate the R1 value:

$$R1 \cong \left(\frac{20\text{mV}}{2 \cdot V_{\text{out}}} \right) \left(\frac{L1}{T_{\text{min}}} \right) \left(\frac{I_{\text{LOADMAX}}}{2 \cdot I_{\text{OUTSENSE}}} \right)$$

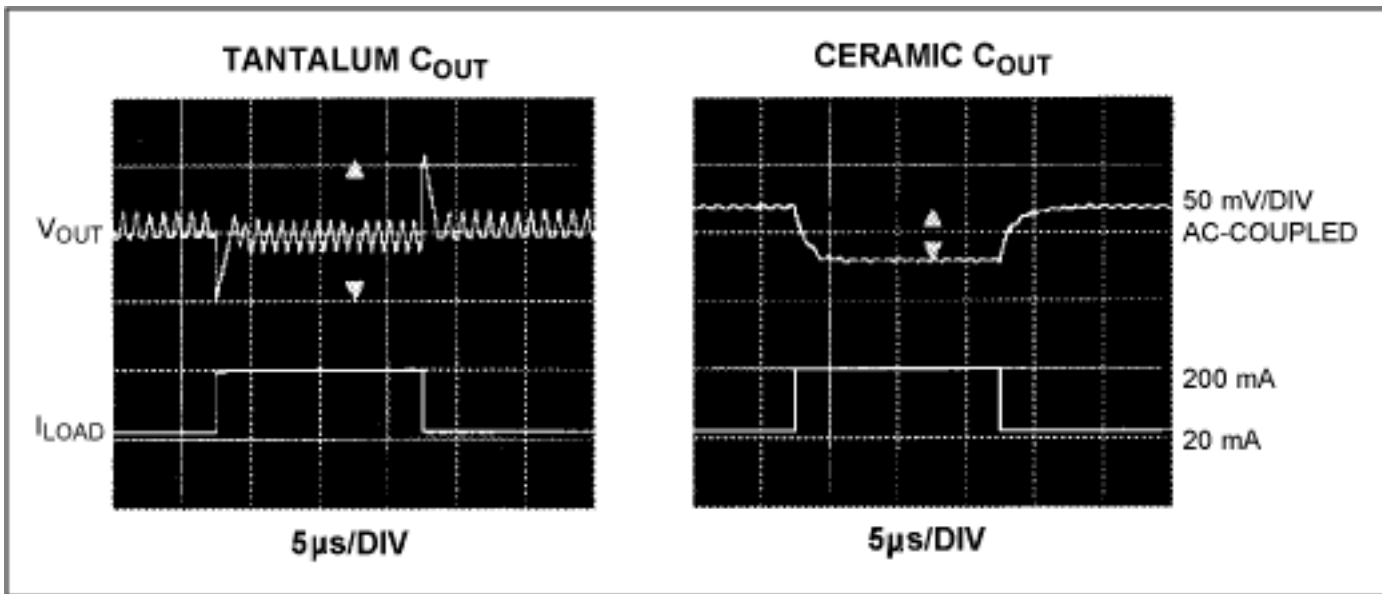

Figure 2. Load-transient response waveforms (top traces) show that a ceramic output capacitor produces lower output ripple and less overshoot.

Per the MAX1734 data sheet, V_{OUT} is 1.5V or 1.8V, $L1$ is 10 μ H, T_{min} is 0.4 μ sec, $I_{LOADMAX}$ is 250mA, and $I_{OUTSENSE}$ is 4 μ A. The result is $R1 = 4.3k\Omega$ for $V_{OUT} = 1.8V$, and $R1 = 5.2k\Omega$ for $V_{OUT} = 1.5V$. $R1$ may therefore be rounded to 5k Ω . Next, calculate the feedforward-capacitor value:

$$C_{ff} \leq \left(\frac{2 \cdot V_{out}}{20mV} \right) \left(\frac{T_{min}}{R1} \right)$$

If $R1 = 5k\Omega$ and $V_{OUT} = 1.5V$, then $C_{ff} \leq 12nF$. Select $C_{ff} = 10nF$. Choosing a much smaller value will cause excessive load-transient overshoot, and choosing a larger value will cause instability under loaded conditions. For optimized load transients, the inductor series resistance should be

$$R_L \cong \frac{L1}{R1 \cdot C_{ff}}$$

In this case the R_L value should be about 200m Ω , which allows use of a small inductor and causes an approximate efficiency drop of only 3% at maximum load. Because the inductor time constant $L1/R_L$ is matched to the feedback time constant $R1 \times C_{ff}$, the short-term load-transient response equals the DC load regulation (Figure 2). If R_L is chosen less than 200m Ω , the peak-to-peak load-transient voltage will increase but the DC load regulation will decrease.

Finally, choose C_{OUT} large enough for stability:

$$C_{out} \geq 2 \cdot \left(\frac{\Delta I_L}{20mV} \right) \cdot T_{min}$$

where ΔI_L is approximately 100mA when the MAX1734 operates with a 10 μ H inductor. In this case, C_{OUT} should be greater than 4 μ F.

¹The MAX1734 stepdown DC-DC converter supplies a fixed 1.8V or 1.5V output at 250mA from an input voltage range of 2.7V to 5.5V. Its 5-pin SOT23 package and internal synchronous rectifier allows a small application circuit with a minimum number of external components.

A similar version of this article appeared in the June 7, 2001 issue of *EDN* magazine.

Application Note 1121: <http://www.maxim-ic.com/an1121>

More Information

For technical questions and support: <http://www.maxim-ic.com/support>

For samples: <http://www.maxim-ic.com/samples>

Other questions and comments: <http://www.maxim-ic.com/contact>

Related Parts

MAX1734: [QuickView](#) -- [Full \(PDF\) Data Sheet](#) -- [Free Samples](#)

AN1121, AN 1121, APP1121, Appnote1121, Appnote 1121

Copyright © by Maxim Integrated Products

Additional legal notices: <http://www.maxim-ic.com/legal>