



APPLICATION NOTE 1115

Isolated SLIC Supply

Some subscriber line interface cards (SLICs) require power-supply voltages isolated from the local supply. The **Figure 1** circuit generates three such isolated voltages from a 5V input: +3.3V at 100mA, -24V at 100mA, and -72V at 25mA. It features a boost controller (U1) operating in a transformer flyback topology, and an optocoupler for isolating the feedback signal. To provide this feedback (from the -24V output to the boost controller) the optocoupler (U4) is driven by a shunt voltage regulator (U3) acting as an error amplifier.

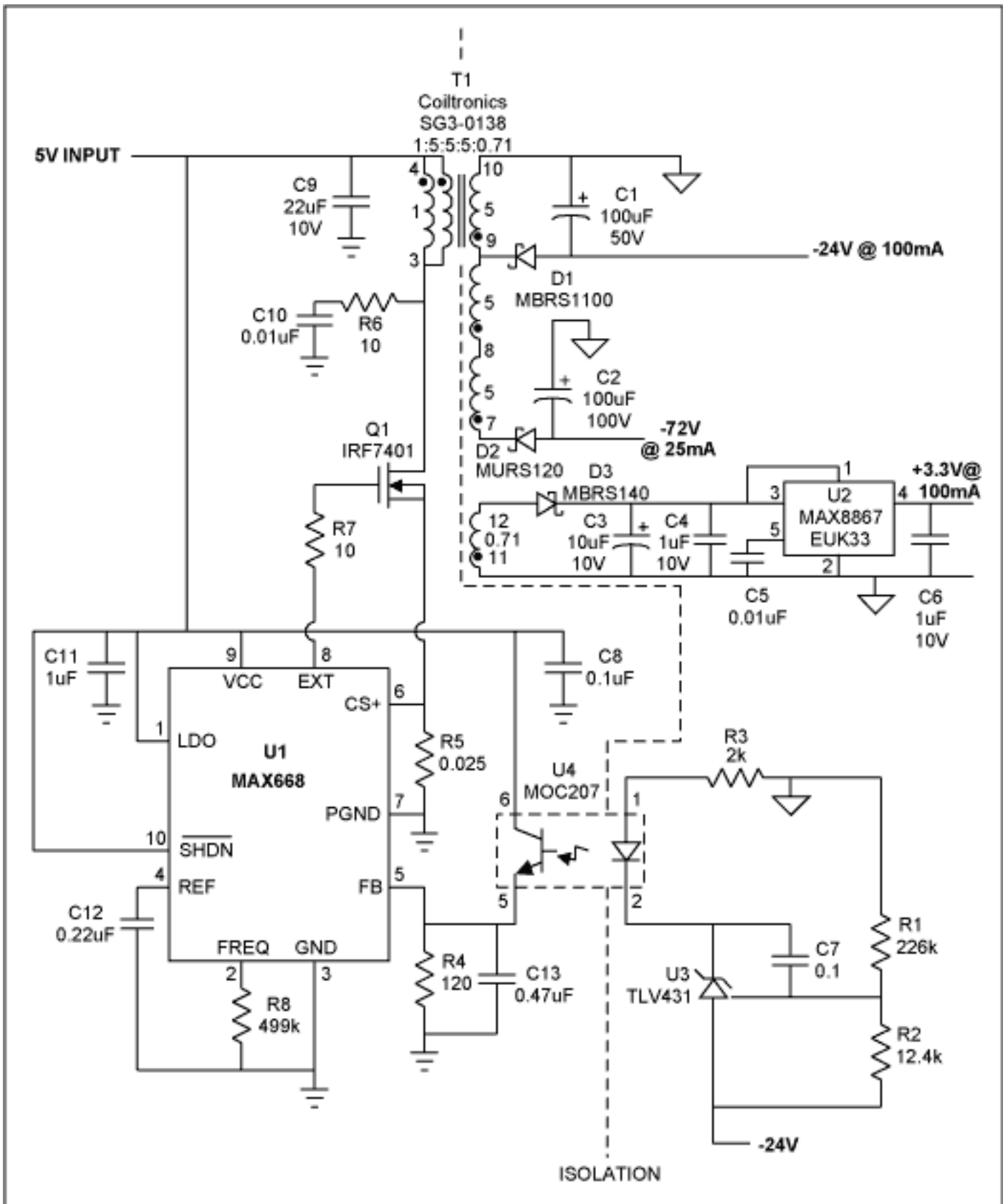

Figure 1. This SLIC power supply isolates the three outputs (+3.3V, -24V, and -72V) with a transformer, and isolates the feedback signal with an optocoupler.

The wide range of output voltages requires a custom transformer. Its core is a standard-geometry Coiltronics SG3-0138 with $A_L = 138\text{nH/T}^2$. The primary inductance is $6.8\mu\text{H}$, and the peak primary current is 4A. The primary-to-secondary turns ratio is 1:5, so for best efficiency the converter operates with a duty cycle near 50%. The unregulated -72V output is derived from the regulated -24V output via three identical secondary windings connected in series. Also available is a tap for a -48V output, and a low-voltage winding that drives a

linear voltage regulator (U2) to provide the +3.3V output. The transformer's winding specs are:

Primary: 7T 28AWG bifilar

Secondary: 35T 32AWG

35T 32AWG

35T 32AWG

5T 32AWG

At maximum specified load with an input of 5.0V at 1.138A, the circuit yields 80% efficiency while delivering +3.28V at 103.9mA, -24.0V at 100mA, and -73.2V at 25.2mA.

V_{IN} (V)	I_{in} (A)	V_o (V)	I_o (mA)	V_o (V)	I_o (mA)	V_o (V)	I_o (mA)	Eff. (%)
4.50	1.27	24.01	100.2	73.2	25.2	3.28	103.9	80.3
5.01	1.138	24.01	100.2	73.2	25.2	3.28	103.9	80.5
5.50	1.038	24.01	100.2	73.2	25.2	3.28	103.9	80.4

Notes:

1. T1 is wound on a standard geometry core with $138\text{nH}/\text{T}^2$.
Primary inductance is $6.7\mu\text{H}$.
Primary is 7 turns of #28 bifilar.
Tapped secondary is three layers of 35 turns each of #32 per tap.
Low voltage secondary is 5 turns of #32.

A similar version of this article appeared in the September 24, 2001 issue of *EE Times* magazine.

Application Note 1115: <http://www.maxim-ic.com/an1115>

More Information

For technical questions and support: <http://www.maxim-ic.com/support>

For samples: <http://www.maxim-ic.com/samples>

Other questions and comments: <http://www.maxim-ic.com/contact>

Related Parts

MAX668: [QuickView](#) -- [Full \(PDF\) Data Sheet](#) -- [Free Samples](#)

AN1115, AN 1115, APP1115, Appnote1115, Appnote 1115

Copyright © by Maxim Integrated Products

Additional legal notices: <http://www.maxim-ic.com/legal>