

APPLICATION NOTE 111

Dual, Voltage-Output DAC Consumes Miniscule Power

Abstract: This design note shows a circuit that modifies a dual, voltage-output digital-to-analog converter (DAC) to save power and draw less than 20µA from a 5V supply. This circuit is useful for programmable voltage generation in slow or static applications, such as the nulling of offsets in a micropower instrument.

A similar version of this article appeared in *Electronic Design* magazine.

The dual, voltage-output DACs shown in the figure below employ a combination of power-conserving tricks to draw less than 20µA from a 5V supply. The circuit suits a need for programmable voltage generation in slow or static applications, such as the nulling of offsets in a micropower instrument.

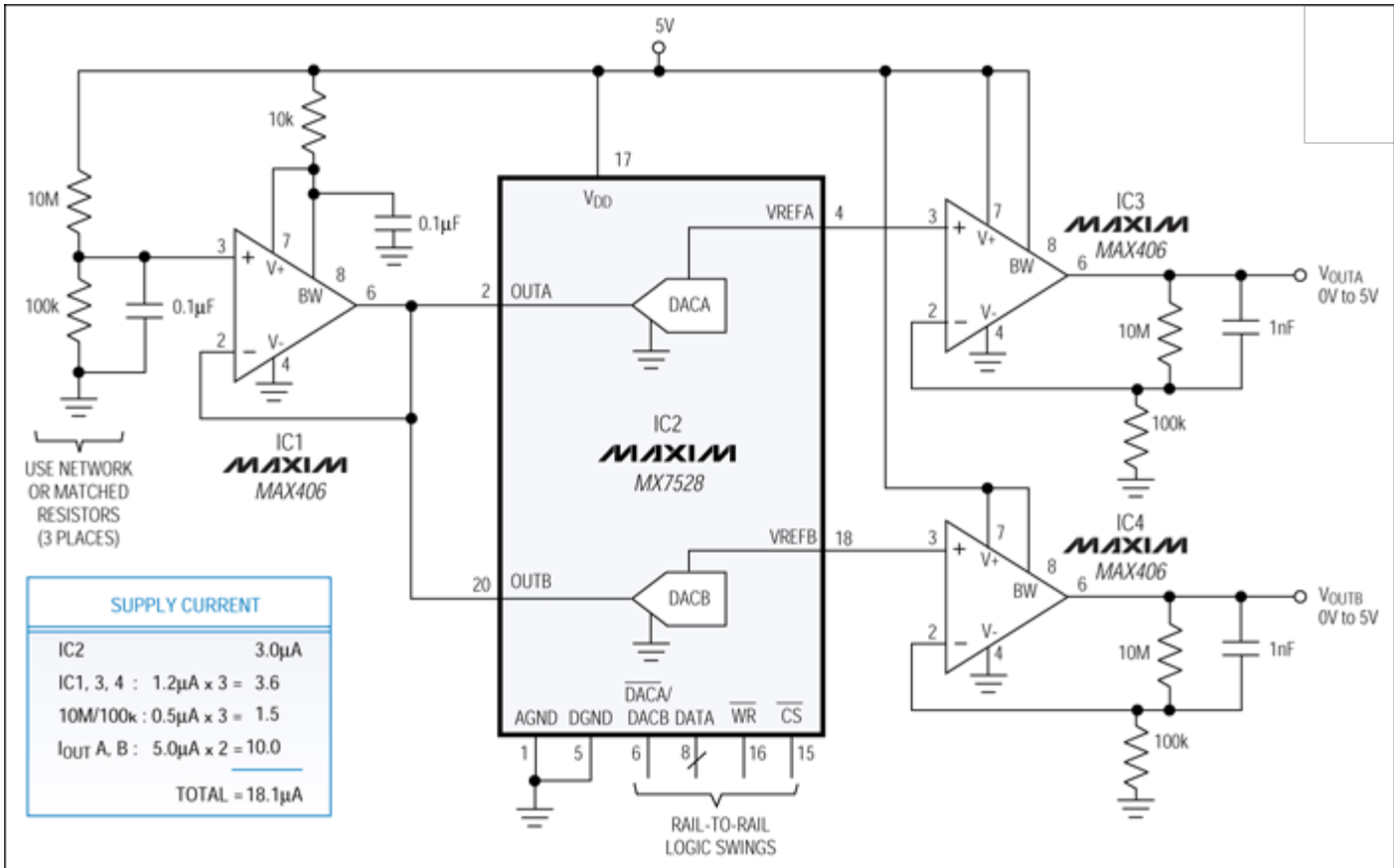

Providing two independent 8-bit DACs with voltage outputs and a common reference, this dual-DAC circuit draws less than 20µA from a 5V supply.

Current-output DACs normally waste power by routing the complement of I_{OUT} to ground. The circuit in the figure avoids wasting power by operating each DAC in the reverse voltage-switching mode, in which the reference voltage is applied to the pins normally labeled I_{OUT}.

The OUT pins in this circuit have a constant and relatively low input impedance of 11kΩ. To reduce input currents, the reference voltage is divided by 100 (from 5V to 50mV) and therefore delivers only 5µA to each DAC input. Signal levels are restored by a compensating gain of 100 in each output amplifier. Inexpensive 10MΩ/100kΩ resistor networks are a good choice for the multiple 100:1 attenuators required. Though only 2% accurate, their matching and tracking is much better than that of discrete resistors.

Greater scaling is impractical because of 0.5mV (maximum) offsets in the output amplifiers shown. Amplified by 100, these offsets produce worst-case output errors of $\pm 1\%$ (0.05V). The errors are constant over temperature, but additional error due to drift over a range of 40°C is typically $\pm \frac{1}{2}$ LSB. The micropower output amplifiers shown in the figure were chosen for their low supply current—their typical I_{DD} is only 1 μ A.

The last requirement for minimizing the overall current drain is to ensure that logic signals applied to the digital inputs of IC1 swing to within 0.2V of each rail. The maximum specified I_{DD} for that condition is 100 μ A over temperature, but this specification (like most CMOS I_{DD} ratings) is extremely conservative. I_{DD} is negligible for rail-to-rail swings but rises dramatically as the swings approach TTL levels.

Related Parts

[MAX406](#) Single, Dual, Quad, 1.2 μ A Max, Single-Supply Op Amps

[MX7528](#) CMOS, Dual, Buffered, 8-Bit Multiplying DAC -- [Free Samples](#)

Automatic Updates

Would you like to be automatically notified when new application notes are published in your areas of interest? [Sign up for EE-Mail™](#).

Application note 111: www.maxim-ic.com/an111

More information

For technical support: www.maxim-ic.com/support

For samples: www.maxim-ic.com/samples

Other questions and comments: www.maxim-ic.com/contact

AN111, AN 111, APP111, Appnote111, Appnote 111

Copyright © by Maxim Integrated Products

Additional legal notices: www.maxim-ic.com/legal