

Application Note:

HFAN-2.3.1

Rev.1; 04/08

Maintaining Average Power and Extinction Ratio, Part 1

Slope Efficiency and Threshold Current



Maxim Integrated Products



Maintaining Average Power and Extinction Ratio, Part 1 Slope Efficiency and Threshold Current

1 Introduction

As the size and area of optical modules decreases, the operating temperature increases due to the close proximity of the modules in a complete system. Small form factor (SFF, SFP) modules, for example, allow for very high module densities on a line card. The elevated temperatures associated with the high module density can have a significant effect on the module's performance due to the temperature dependent variables of the laser. Careful consideration of the laser parameters as a function of temperature is essential in low-cost small form factor module design.

The purpose of this application note series (Part 1 and Part 2) is to demonstrate by practical example how the laser properties can change over temperature and how to compensate for these changes in order to maintain constant extinction ratio and average power.

Part 1 gives a brief background on threshold current, slope efficiency, average power, and extinction ratio. The temperature dependence of these laser parameters is then illustrated by presenting measurement results from three different lasers.

Part 2 of this application note series will build on the information obtained in part 1 and show how to maintain the extinction ratio and the average power constant over temperature, using an SFF module (reference 1).

2 Background Information

Most fiber-optic transmitters are required to maintain system performance over a broad temperature range (e.g., -40°C to $+85^{\circ}\text{C}$). This application note focuses on two important optical parameters, average power and extinction ratio. These optical parameters are derived from the slope efficiency and threshold current associated with the

laser diode. The behaviors of these laser characteristics as a function of temperature must be known and accounted for in order to maintain the system performance.

2.1 Threshold Current

Laser diodes emit coherent light once the optical gain has surpassed the mirror loss in the Fabry-Perot (FP) cavity. The current associated with the point of initial coherent light emission is known as the threshold current (I_{th}). As temperature increases, the optical gain decreases. As the gain decreases, more current is needed for coherent light emission (Figure 1), and therefore the threshold current increases.

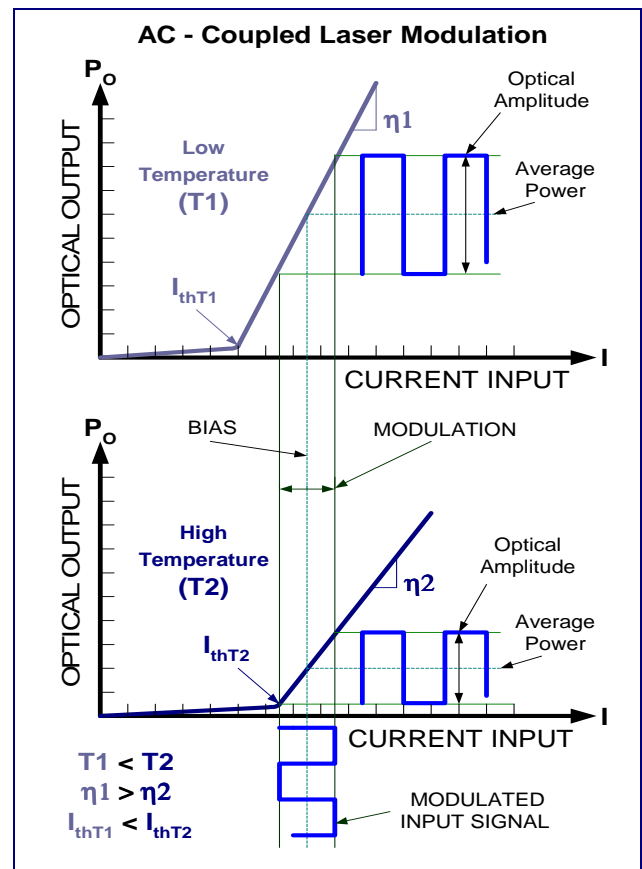

Figure 1. Optical Output vs. Laser Current

Figure 2 shows the approximate threshold current over temperature for a given laser using measured data. Over temperature, the threshold current was seen to increase by more than 20mA.

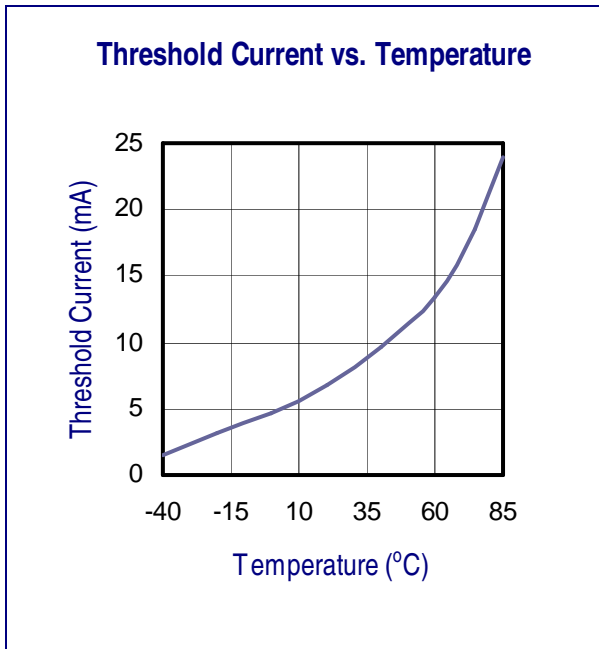

Figure 2. Threshold Current vs. Temperature

2.2 Slope Efficiency

Once the laser is biased above the threshold, the ratio of the optical output to laser current is defined as the slope efficiency (η , see Table 1). In general, the slope efficiency of an edge-emitting laser decreases with increased temperature (Figure 1). As slope efficiency decreases, more modulation current is needed to maintain the same optical output amplitude. For more information see references 2 and 3.

Table 1. Optical Equations

Parameter	Symbol	Relation
Average Power	P_{AVG}	$P_{AVG} = \frac{P_0 + P_1}{2}$
Extinction Ratio	r_e	$r_e = \frac{P_1}{P_0}$
Optical Amplitude	P_{P-P}	$P_{P-P} = P_1 - P_0$
Laser Slope Efficiency	η	$\eta = \frac{P_{P-P}}{I_{MOD}}$
Bias Current (AC - Coupled)	I_{BIAS}	$I_{BIAS} \geq I_{TH} + \frac{I_{MOD}}{2}$
Laser to Monitor Transfer	ρ_{MON}	$\rho_{MON} = \frac{I_{MD}}{P_{AVG}}$

2.3 Average Power Compensation

The average optical power can change dramatically over temperature due to changes in threshold current. As the threshold current increases, more laser current is required to maintain the same average power.

In order to compensate for changes in threshold current, automatic power control (APC) loops can be used (Figure 3). The APC loop monitors the back-facet photodiode current and adjusts the bias current in order to keep the photodiode current constant. Given that the relationship between the photodiode current and average power is ideally linear, the average power is held constant by keeping the photodiode current at a constant level.

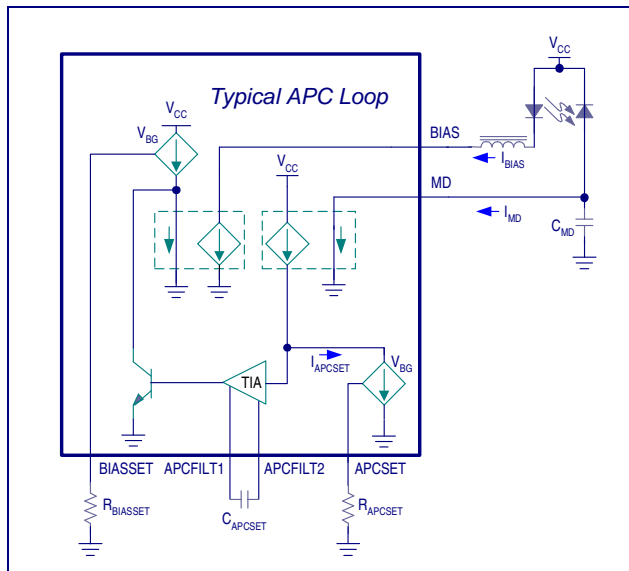

Figure 3. Typical APC Loop

The APC loop is a common feature on almost all of Maxim's laser drivers. As long as the transfer between the laser and photodiode is constant, the APC loop works well in maintaining average power over life of the laser and over temperature due to its closed-loop form. Other compensation methods, such as thermistors and digital look-up tables, can also be used to maintain average power, but are unable to compensate over the life of the laser due to their open-loop form.

2.4 Extinction Ratio Compensation

The slope efficiency of the laser can also change greatly over temperature. This change in slope efficiency can easily cause the extinction ratio to vary by 4dB or more, from -40°C to $+85^{\circ}\text{C}$, when the average power is held constant.

Large changes in extinction ratio (when the average power is held constant) can cause considerable variations in the systems bit error ratio (BER) over the specified temperature range (reference 3). Given the large variations (and the corresponding degradation in BER), the extinction ratio must be set at undesirably large values at nominal temperature in order to meet specification over the full temperature range. For example, it is common to design systems to have extinction ratios of 12dB or more at room temperature in order to maintain the SONET minimum of 8.2dB over the full temperature range.

In practice, obtaining a large extinction ratio is difficult due to relaxation oscillation, increased jitter

and the power limits of the lasers (reference 2). The increased jitter associated with large extinction ratios decreases eye openings and the overall system BER performance. This is illustrated in Figures 4 and 5.

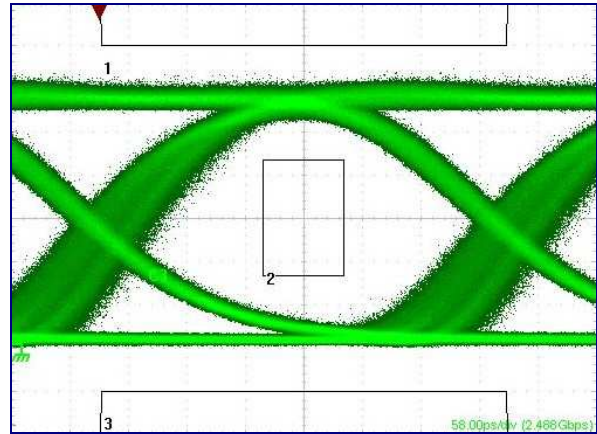

Figure 4. OC-48 Optical Eye, 14dB extinction ratio

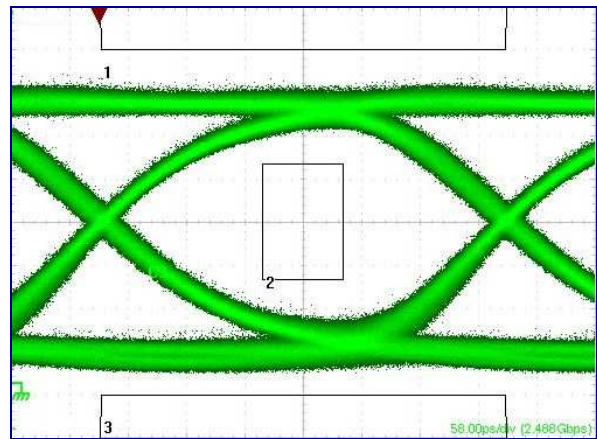

Figure 5. OC-48 Optical Eye, 8.2dB extinction ratio

Figure 4 is an optical eye diagram with a standard mask (OC-48) at 14dB extinction ratio using a $2^{23}-1$ PRBS. Figure 5 is the same device but with an extinction ratio of 8.2dB. Operating at 8.2dB extinction ratio, the standard mask was increased by 21% before mask violations occurred. When operating at 14dB extinction ratio, only 14% margin was obtained. As seen from Figures 4 and 5, increasing the extinction ratio as much as possible is not always the best solution. Careful consideration of the optical jitter, eye width, eye height, power penalty and overall system BER should be considered when choosing the operating extinction ratio.

Just as with average power compensation, a closed and open loop implementation may be used to minimize variations in extinction ratio for changes in laser slope efficiency. For example, the MAX3865 laser driver uses closed loop feedback to create an automatic modulation control (AMC) circuit (references 4 and 5). The MAX3863 (reference 6) uses a feedback loop that applies additional modulation current proportional to the bias current increase. The MAX3996 (reference 7) uses temperature coefficient compensation. Other methods include digital resistors with temperature controlled look-up tables such as the Dallas DS1847. (Note: Part 2 of this application note series illustrates how to use the MAX3863 and the DS1847 to maintain average power and extinction ratio.)

3 Test Setup

The critical parameters of three lasers were measured in order to demonstrate the laser output power variations that are caused by changes in temperature. Each of the three lasers was evaluated using the same PC board in order to eliminate part-to-part variations due to the laser driver and other passive components that are used to drive the laser diodes. The basic test setup is shown in Figure 6.

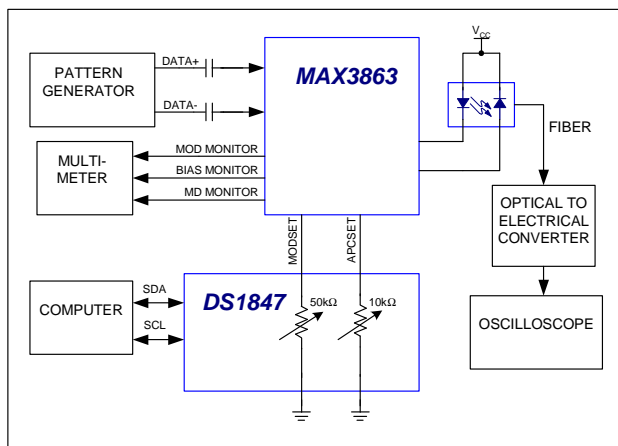

Figure 6. Setup Diagram

The lasers evaluated were 1310nm MQW-FP laser diodes packaged in a TO-46 can with a sleeve to accept an LC type ferrule. All three were the same model and part number.

The MAX3863 laser driver and DS1847 digital variable resistors were used as a reference for driving the lasers. Monitors for modulation, bias and

monitor diode currents on the MAX3863 were used to measure the optical currents.

An OC-48, $2^{23}-1$ PRBS data pattern was used when measuring extinction ratio and average power. A summary of the data collected is presented in section 8 on page 8.

4 Variation in threshold current

To compensate for changes in threshold current, the APC loop of the MAX3863 was used. Using an external resistor (R_{APCSET}), the MAX3863 sets the photodiode current level by adjusting the laser bias current. Using the same resistance setting, the photodiode current for each of the three lasers was measured from -40°C to $+85^{\circ}\text{C}$.

As seen in Figure 7, the APC loop maintains the photodiode current variation to only $8\mu\text{A}$ over the full temperature range. Photodiode current variations of $8\mu\text{A}$ would account for less than 1% variation in the average power, but the measured average power varies by a considerably larger amount.

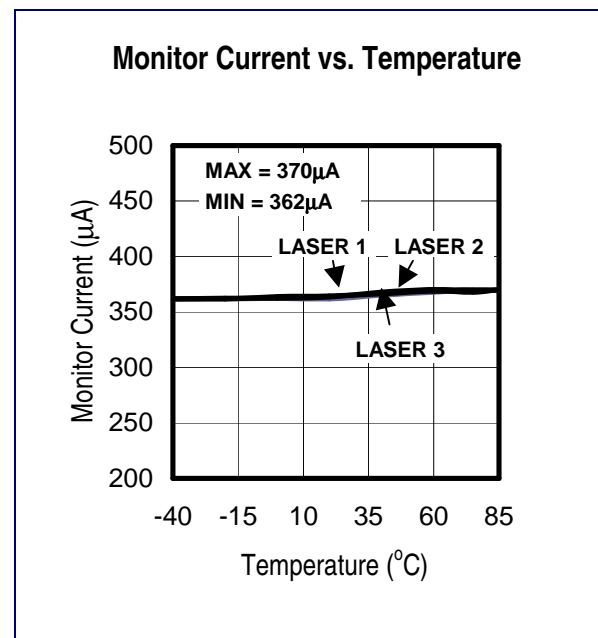

Figure 7. Monitor Current vs. Temperature

Figure 8 shows the measured average optical power vs. temperature. This figure shows that setting the photodiode the same for every laser does not necessarily translate to the same average power for each laser. For example, comparing Figures 7 and 8 shows that at 25°C there was less than $3\mu\text{A}$ of variation in photodiode current, but more than

0.5dBm variation in measured average optical power.

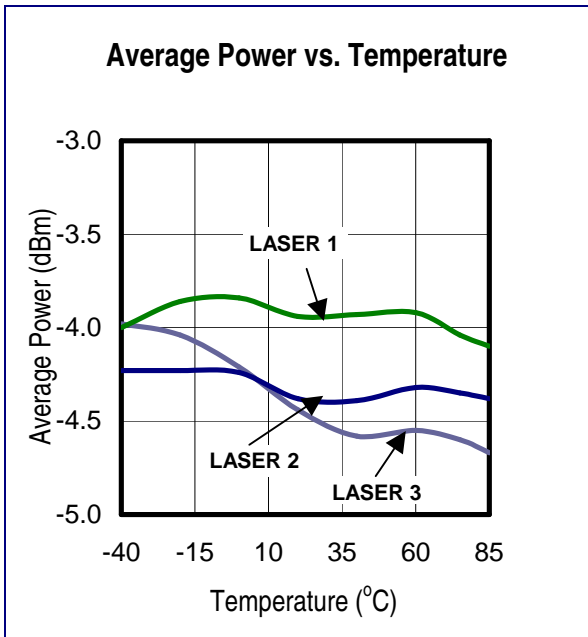

Figure 8. Average Power vs. Temperature

Not only does the average power vary from part to part, but the average power of each individual laser also changes over temperature. Variations in the measured average power are caused by changes in photodiode responsivity, laser-to-monitor coupling, and laser-to-fiber coupling. Compensating for these factors is difficult since they do not always behave in the same way for each laser. For instance, the coupling from the laser to the fiber could increase or decrease with temperature. Due to these parameters, 10% or more variation in measured average power can generally be expected.

5 Variation in Slope Efficiency

As seen in Figure 9, the slope efficiency of the three lasers decreased with increased temperature. The slope efficiency of laser 3, for example, was .020 (mW/mA) at -40°C and .011 (mW/mA) at +85°C. If no compensation were applied, the overall change in extinction ratio would be 5.5dB (Figure 10). In order to keep the extinction ratio above 8.2dB, the 25°C operating extinction ratio would need to be set at 12dB, giving 14.8 at -40°C and 8.2db at +85°C.

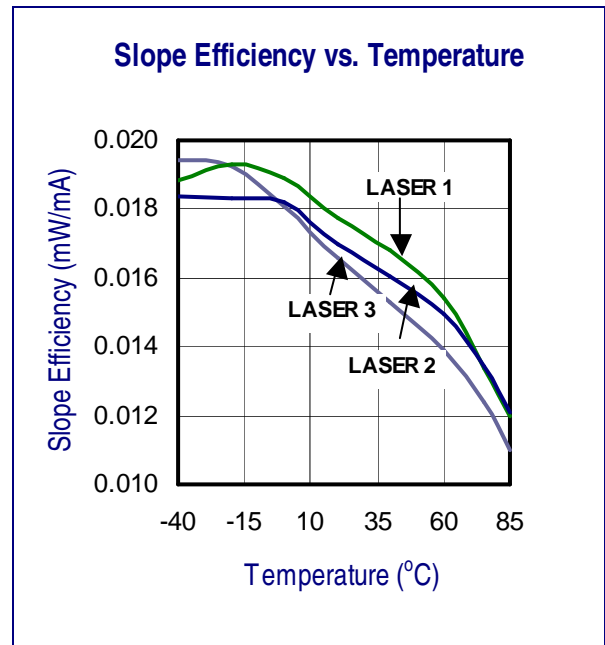

Figure 9. Slope Efficiency vs. Temperature

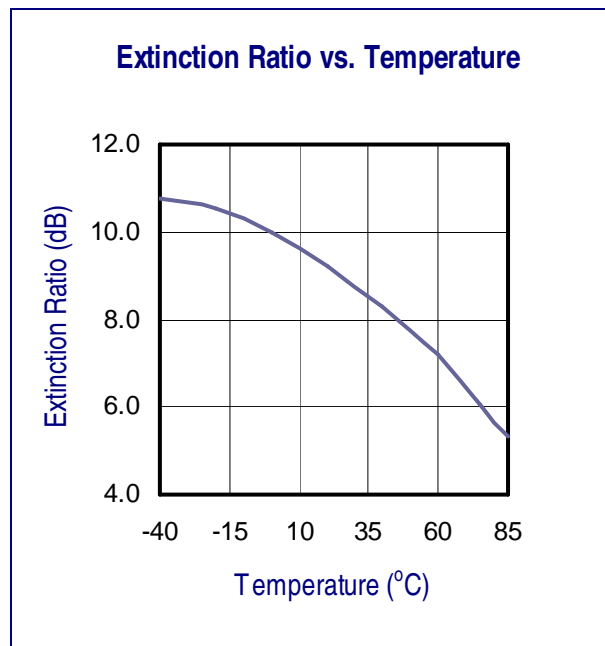

Figure 10. Extinction Ratio vs. Temperature

To maintain extinction ratio, the modulation current must be increased at high temperatures. Given the slope efficiency vs. temperature, the modulation current needed to maintain a 9.2dB extinction ratio was calculated for each of the three lasers (Figure 11). On average, the modulation current required at +85°C was approximately 17mA greater than the modulation current required at -40°C. Variation in the required modulation current (Figure 11) shows the need for calibration of the modulation current at

the production level as well as the photodiode current (Figure 8).

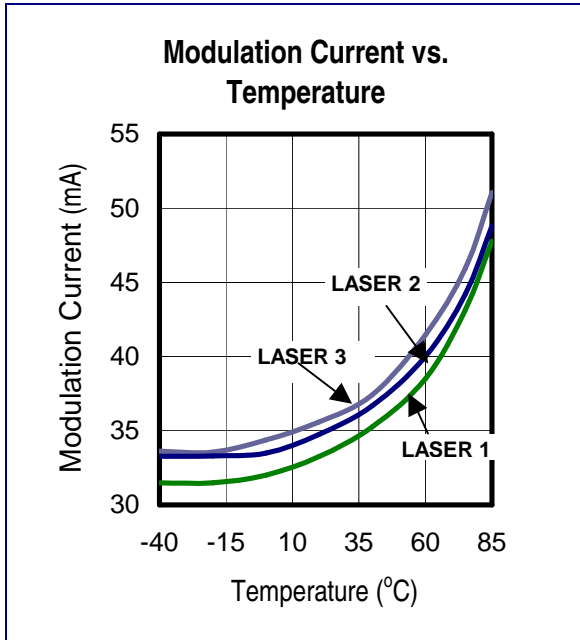

Figure 11. Modulation Current vs. Temperature

6 Conclusion

Variations in slope efficiency and threshold current can cause large variations in the average power and extinction ratio of a laser diode. Neglecting these variations can lead to poor system performance at elevated temperatures.

Part 2 of this application note series shows the results of two methods of compensating for temperature induced changes in threshold current and slope efficiency.

7 References:

1. [Reference Design: "2.5Gbps SFF Transmitter."](#) – HFRD 02.0, Document may also be obtained by calling Customer Applications hot line at 503-547-2400.).
2. [Application Note: "Interfacing Maxim Laser Drivers with Laser Diodes."](#) – HFAN 02.0, Maxim Integrated Products, May 2000.
3. [Application Note: "Extinction Ratio and Power Penalty."](#) – HFAN 02.2.0, Maxim Integrated Products, May 2001.
4. [Application Note: "The MAX3865 Laser Driver with Automatic Modulation Control."](#) – HFDN 18.0, Maxim Integrated Products, December 2001.
5. [Data Sheet: "MAX3865: 2.5Gbps Laser Driver with Automatic Modulation Control."](#) - Maxim Integrated Products, October 2001.
6. [Data Sheet: "MAX3863: 2.7Gbps Laser Driver with Modulation Compensation."](#) - Maxim Integrated Products, January 2002.
7. [Data Sheet: "MAX3996: 3.0 to 5.5V, 2.5Gbps VCSEL and Laser Driver."](#) - Maxim Integrated Products, February 2002.

8 Summary of Laser Data:

LASER #1	Temperature (°C)	Photodiode Current (mA)	Bias Current (mA)	Modulation Current (mA)	Slope Efficiency (mW/mA)	Extinction Ratio (dB)	Average Power (dBm)
	-40	362	22.1	34.1	0.019	10.3	-4.0
	-20	362	23.7	34.1	0.019	10.3	-4.0
	0	362	25.7	34.1	0.018	9.8	-4.2
	20	362	28.4	34.1	0.017	9.2	-4.4
	40	365	32.4	34.1	0.015	8.4	-4.6
	60	368	38.7	34.1	0.014	7.1	-4.6
	75	370	46.5	34.1	0.012	6.1	-4.6
	85	370	55.0	34.1	0.011	5.4	-4.7

LASER #2	Temperature (°C)	Photodiode Current (mA)	Bias Current (mA)	Modulation Current (mA)	Slope Efficiency (mW/mA)	Extinction Ratio (dB)	Average Power (dBm)
	-40	362	22.6	35.7	0.019	10.8	-4.0
	-20	362	24.3	35.7	0.019	10.5	-3.9
	0	364	26.4	35.7	0.019	10.0	-3.8
	20	364	29.2	35.7	0.018	9.2	-3.9
	40	366	33.3	35.7	0.017	8.3	-3.9
	60	369	39.6	35.7	0.015	7.2	-3.9
	75	368	47.9	35.7	0.013	6.1	-4.0
	85	370	56.4	35.7	0.012	5.3	-4.1

LASER #3	Temperature (°C)	Photodiode Current (mA)	Bias Current (mA)	Modulation Current (mA)	Slope Efficiency (mW/mA)	Extinction Ratio (dB)	Average Power (dBm)
	-40	362	22.0	33.7	0.018	10.0	-4.2
	-20	362	23.5	33.7	0.018	10.0	-4.2
	0	362	25.1	33.7	0.018	9.9	-4.2
	20	363	27.8	33.7	0.017	9.2	-4.4
	40	368	31.5	33.7	0.016	8.3	-4.4
	60	370	37.4	33.7	0.015	7.2	-4.3
	75	370	45.0	33.7	0.013	6.3	-4.4
	85	370	53.3	33.7	0.012	5.5	-4.4