

APPLICATION NOTE 1084

High-Side Current Sensor Has Period Output

Abstract: The MAX4374 high-side current sense amplifier with two internal comparators is used to produce a pulse-width output signal proportional to the current being sensed. This simple circuit eliminates the need for a discrete A/D converter.

High-side current monitoring is found in many battery-powered products that require accurate monitoring of load current, charger current, or both. In non-portable applications high-side current monitoring serves as a power-supply watchdog that can flag a failure in downstream devices. It can also eliminate hazardous conditions by preventing power-supply overloads. Further, high-side current monitoring of motor/servo currents can produce useful feedback in a control application.

What's needed in these applications is a device that converts high-side current directly to a digital signal (**Figure 1**). IC1 is a low-cost, high-side current-sense amplifier that converts high-side current to a proportional ground-referenced voltage. Its two internal comparators (latching and non-latching) implement a voltage-to-pulse converter that produces a pulse-width output proportional to the measured current.

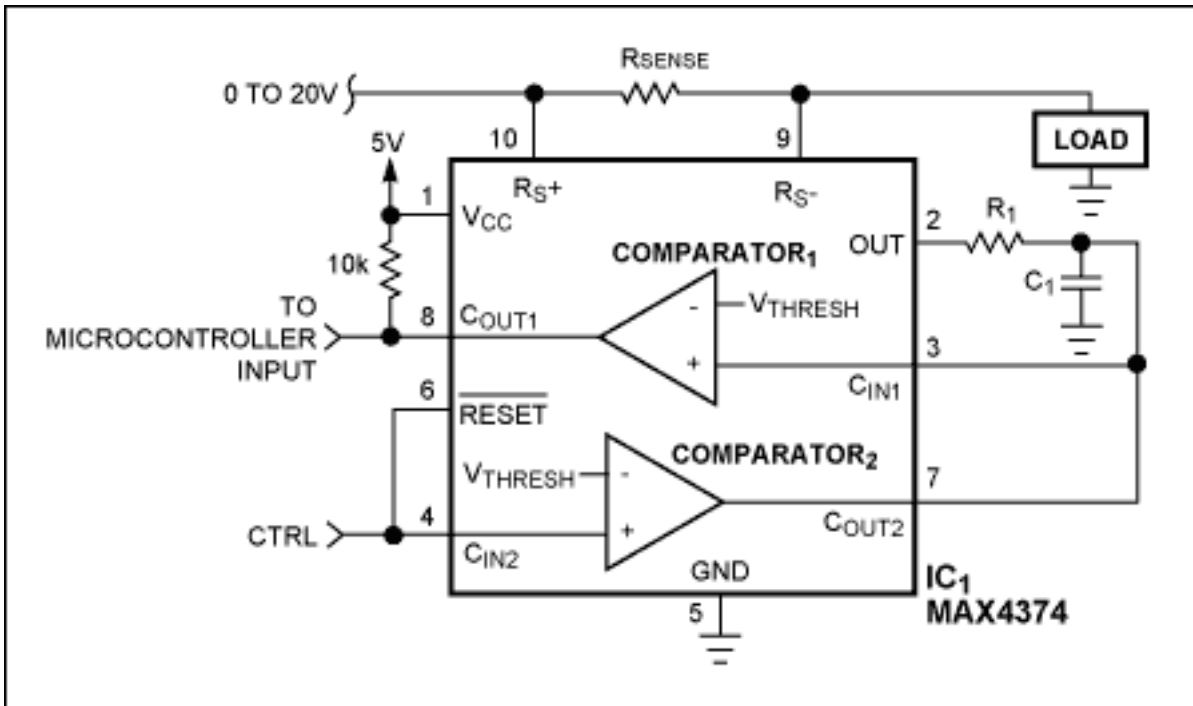

Figure 1. The duration of a negative-going pulse at COUT1 (pin 8) is proportional to the current flowing through Rsense.

IC1's OUT pin charges C1 via R1. When the C1 voltage reaches 0.6V, comparator 1 latches in the high-impedance state. The time required to charge C1 to 0.6V is proportional to the current being measured. Comparator 2 in conjunction with the RESET pin initiates the conversion and removes the pre-charge on C1.

Conversion is controlled by the RESET and CIN2 pins, tied together and connected to a TTL-compatible MCU output (CTRL). Normally, CTRL is high. The MCU starts a conversion by pulsing CTRL low, which discharges C1 and clears the latch on comparator 1 (COUT1 goes low). The MCU now measures time from the CTRL output transition to the low-to-high transition at COUT1 (**Figure 2**). (The period begins at the low-to-high transition of CTRL and ends at the low-to-high transition of COUT1.)

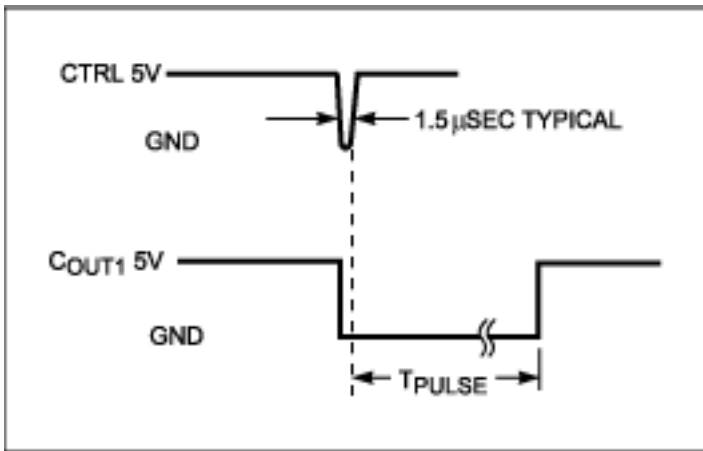

Figure 2. These waveforms illustrate operation of the Figure 1 circuit.

In response to the current levels of interest, RC is selected to create pulse durations in the tens of milliseconds. As a result, the OUT settling time (20μsec) and the comparator propagation delays (4μsec) have negligible effects on the measurement accuracy. To derive an expression for the output pulse width, start with the relationship for an RC-charging circuit:

$$V_{\text{thresh}} = \text{Out}(1 - e^{-T_{\text{pulse}}/R_1C_1})$$

For "Out" (voltage at the Out terminal in Figure 1), substitute the expression ($I_{\text{load}} \times R_{\text{sense}} \times A_v$), and solve for I_{load} :

$$I_{\text{load}} = V_{\text{thresh}} / (R_{\text{sense}} \times A_v (1 - e^{-T_{\text{pulse}}/R_1C_1})), \text{ where}$$

I_{load} = measured current in amps

V_{thresh} = comparator threshold = 0.6V

R_{sense} = current-sense resistance in Ω

A_v = gain of IC1

T_{pulse} = time required to charge C1 to V_{thresh} (in seconds)

For example, when selecting $R_1 = 1\text{M}$, $C_1 = 0.1\mu\text{F}$, $R_{\text{sense}} = 0.075\Omega$, and $A_v = 20$; this produces a T_{pulse} measurement of 0.022 seconds in response to a 2A current. Thus, given an MCU timer port, an external interrupt, or simply an available MCU input, IC1 and two external passive components implement high-side current-to-digital conversion without need for a discrete A/D converter.

A similar version of this article appeared in the March 7, 2002 issue of *EDN* magazine.

Application Note 1084: www.maxim-ic.com/an1084

More Information

For technical support: www.maxim-ic.com/support

For samples: www.maxim-ic.com/samples

Other questions and comments: www.maxim-ic.com/contact

Automatic Updates

Would you like to be automatically notified when new application notes are published in your areas of interest?
[Sign up for EE-Mail.](#)

Related Parts

MAX4374: [QuickView](#) -- [Full \(PDF\) Data Sheet](#) -- [Free Samples](#)

AN1084, AN 1084, APP1084, Appnote1084, Appnote 1084

Copyright © by Maxim Integrated Products

Additional legal notices: www.maxim-ic.com/legal