



APPLICATION NOTE 1062

Designing Compact Telecom Power Supplies

Abstract: This application note describes a compact 5W flyback, high-frequency, switching converter for Telecom applications. Most aspects of the design process are discussed: power-stage selection and design, transformer design, core size calculations, RCD snubber design, MOSFET selection, input and output filter designs, frequency compensation, power-loss and efficiency calculation, and layout and safety guidelines.

Telecom power supplies are specified for operation over a wide input-voltage range (36V to 75V) but with circuit performance optimized at 48V. Such circuit designs should be compact, efficient, and have a low profile to comply with the tight spacing between cards. This app note discusses a 5W flyback converter for telecom applications, based on the MAX5021 IC—a universal offline power-supply controller.

Telecom systems include numerous line cards. Connected in parallel to the high-power backplane, each has its own input-filter capacitor and low-voltage power converter. The large number of input-filter capacitors in parallel limits the value of each to a few microfarads, making the power-supply design fairly difficult.

The MAX5021 IC is a high-frequency, current-mode PWM controller suitable for wide-input-range, isolated telecom power supplies. It enables the design of small, efficient, power-converter circuits. A fixed-switching frequency of 262kHz controls switching losses while allowing moderately small power components. The IC includes undervoltage lockout capability with large hysteresis and a low startup current. This results in low-loss designs for power supplies that feature a wide input-voltage range and low output power. Cycle-by-cycle current limiting (achieved with a fast internal comparator) reduces overdesign in the MOSFET and transformer. Other features include maximum-duty-cycle limiting and high-peak capability for the source and sink-drive currents. A reference design (**Figure 1**) illustrates the 5W flyback converter with an input-voltage range of 36V to 72V.

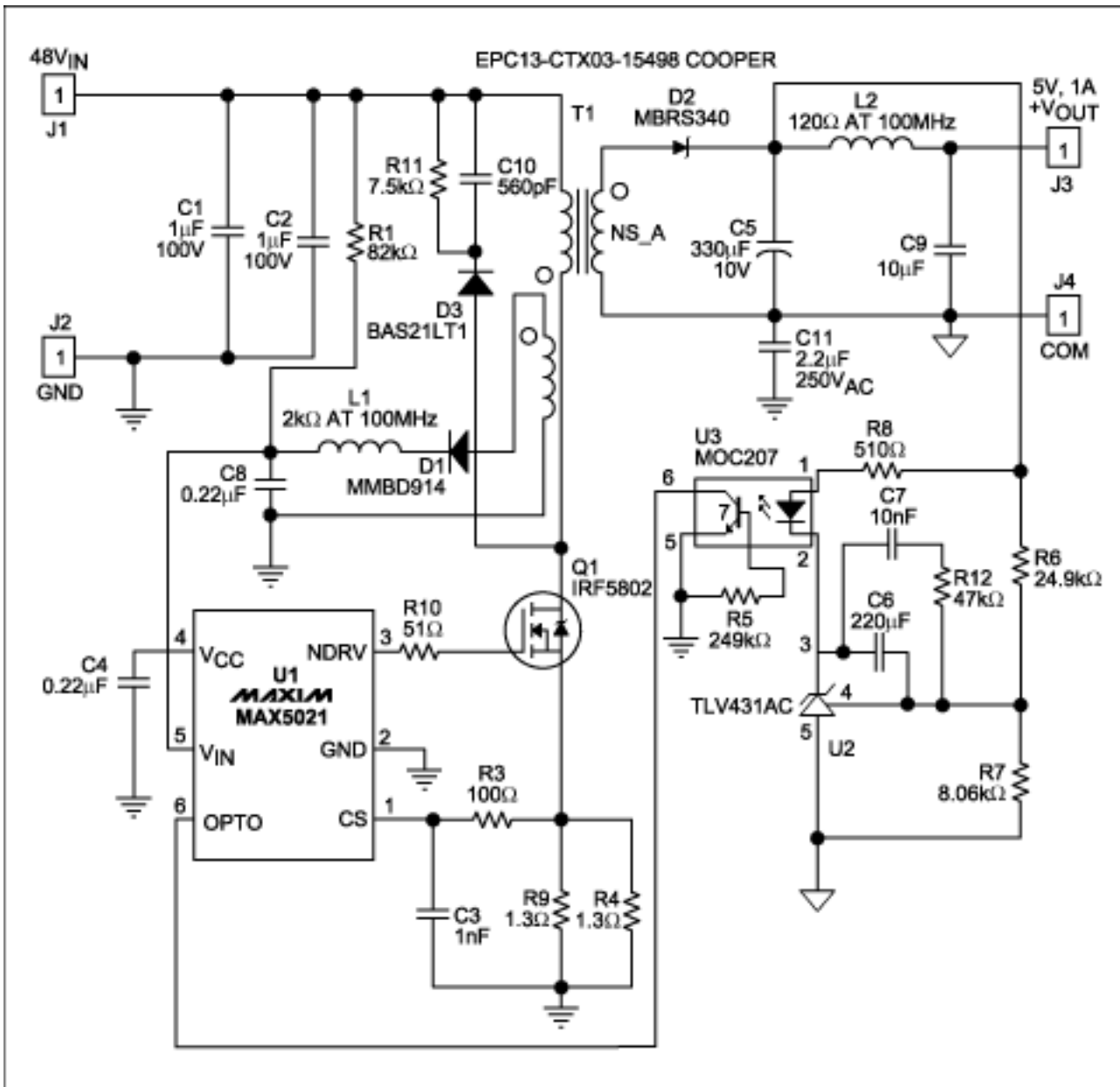

Figure 1. Based on the MAX5021 PWM controller, this flyback converter for telecom applications delivers 5W at 5V.

Power-stage Design

The first step in designing a power supply is deciding on a conversion topology. Topology selection criteria include the input-voltage range, output voltage, peak currents in the primary and secondary circuits, efficiency, form factor, and cost.

The best choice for a 5W output with a 1:2 input-voltage range and small form factor is a flyback topology whose minimum component count reduces the cost and form factor. The flyback transformer can be designed to operate either in continuous or discontinuous mode. Discontinuous mode causes the transformer core to complete its energy transfer during the off cycle, and continuous mode allows the next cycle to begin before the energy transfer is complete. In the present case, discontinuous mode is chosen for the following reasons: it maximizes energy storage in the magnetic component (thereby reducing the component's size); it simplifies compensation (no right-half-plane zero); and it yields a higher unity-gain bandwidth.

A disadvantage of the discontinuous operating mode is the higher ratio of peak-to-average current in the primary and secondary circuits. A higher ratio means higher RMS current, which leads to higher loss and lower efficiency. For low-power conversion, the advantages of discontinuous mode easily surpass the disadvantages.

Moreover, the IC's drive capability is sufficient for driving the large switching MOSFET necessary to carry these peak currents. A telecom application using the MAX5021 in this topology easily achieves power outputs to 15W using standard MOSFETs.

Transformer Design

The key to low loss and high efficiency in the transformer is a proper core. The core and the winding-area product determine the amount of power the transformer can handle with an acceptable rise in temperature. Also considered in the core selection are the topology (ratio of average to RMS current in the winding), output current, efficiency, and form factor. The design of a discontinuous-mode transformer is explained below, step by step. Note that the first equation is a general one, and the second is specific to the MAX5021 power supply with a 40°C temperature rise.

- Estimate the minimum area-product requirement, and select a core and bobbin with suitable form factor.
- Calculate the secondary-winding inductance for guaranteed core discharge within the minimum off-time.
- Calculate the primary-winding inductance for sufficient energy to support maximum load.
- Calculate the number of turns in the primary.
- Calculate the number of turns in the secondary and bias windings.
- Calculate the A_L value of the core.
- Calculate the RMS current in the primary, and estimate the secondary RMS current.
- Consider the proper winding sequence and transformer construction for low leakage.

1. Use the following equation to estimate the minimum area product required:

$$A_p \geq \frac{(1.1 \cdot P_{OUT} \cdot D_{MAX})}{\eta \cdot K_p \cdot K_U \cdot J \cdot K_T \cdot B_{MAX} \cdot f_{SW(MIN)}} \dots(m^4)$$

$$A_p \geq \frac{(2 \cdot P_{OUT}) \cdot 10^{-12}}{\eta \cdot B_{MAX}} \dots(m^4)$$

where:

η = expected efficiency of the converter;

K_p = area assigned to the primary (usually 0.5);

K_T = ratio of RMS to average current in the primary (0.55 to 0.65 for discontinuous flyback);

K_U = window utilization factor (0.4 to 0.5);

J = current density (9.862×10^6 A/m², for winding temperature rise less than 40°C); and

B_{MAX} = maximum-operating flux density in Teslas (use between 0.12T to 0.15T).

Select a core with area product (A_p) equal to or greater than the figure calculated above, and note its core cross section area. Refer to the following table for output power vs. core size, A_p , and core cross-section area (A_e):

Output Power vs. Core Size

Table 1.

Output Power (W)	Core Size	A_p (mm ⁴)	A_e (mm ²)
Up to 2	EPC-10	30	9.4
3 to 4	EEM-12.7	90	12
5 to 8	EPC-13	145	12.5
9 to 12	EFD-15	216	13.5

(Refer to the Appendix for an example.)

2. As discussed earlier, discontinuous operation requires that the core be discharged during the off-cycle. Secondary inductance determines the time required to discharge the core. Use the following equations to calculate secondary inductance:

$$L_S \leq \frac{(V_O + V_D) \cdot (D_{\text{OFF(MIN)}})^2}{2 \cdot I_{\text{OUT}} \cdot f_{\text{SW(MAX)}}} \dots (\text{H})$$

$$L_S \leq \frac{430 \cdot 10^{-9} \cdot (V_O + V_D)}{I_{\text{OUT}}} \dots (\text{H})$$

where:

V_D = secondary-diode forward-voltage drop in volts.

I_{OUT} = maximum-rated output current in amperes.

3. Rising current in the primary builds energy in the core during the on-cycle, which is then released to deliver output power during the off-cycle. The primary inductance must hold enough energy during the on-time to support the maximum output power.

$$L_P = \frac{V_{\text{IN(MIN)}}^2 \cdot D_{\text{MAX}}^2 \cdot \eta}{2 \cdot P_{\text{OUT}} \cdot f_{\text{S(MAX)}}}$$

$$L_P = \frac{0.4 \cdot 10^{-6} \cdot V_{\text{IN(MIN)}}^2 \cdot \eta}{P_{\text{OUT}}} \dots (\text{H})$$

4. Next, calculate the primary number of turns necessary to keep the maximum flux density within limits at the maximum V-s product across the primary. The maximum-operating peak current occurs at the maximum duty cycle.

$$N_P = \frac{V_{\text{IN(MIN)}} \cdot D_{\text{MAX}}}{A_e \cdot B_{\text{MAX}} \cdot f_{\text{S(MIN)}}} \dots (\text{T})$$

$$N_P = \frac{2.1 \cdot 10^{-6} \cdot V_{\text{IN(MIN)}}}{A_e \cdot B_{\text{MAX}}} \dots (\text{T})$$

where:

A_e = core cross-section area in square meters.

5. Round off the primary number of turns to the closest integer, and calculate the number of turns for the secondary and bias windings using the rounded-off primary number of turns. Refer to the following equation:

$$N_S = N_P \cdot \sqrt{\frac{L_S}{L_P}} \dots (\text{T})$$

$$N_{\text{BIAS}} = \frac{11.7}{V_{\text{OUT}} + 0.2} \dots (\text{T})$$

The forward-bias drops of secondary- and bias-rectifier diodes are assumed to be 0.2V and 0.7V, respectively. Refer to the diode manufacturer's data sheet to verify these numbers. Again, round off the number of turns for secondary and bias windings to the closest integers.

6. The core's A_L value depends on the air gap in the magnetic path length. Most of the energy is stored in the air gap during the MOSFET's on-time. To reduce electromagnetic radiation, insert the air gap in the center leg of the core.

$$A_L = \frac{L_p}{N_p^2} \cdot 10^9 \dots \frac{nH}{T^2}$$

7. The transformer manufacturer must know the RMS currents in the primary, secondary, and bias windings to decide the thickness of the wire. To keep skin-effect loss under control, only wires thinner than 28AWG are recommended. Multiple wires in parallel can be used to achieve the required copper thickness. Multifilar windings are very common in high-frequency converters. Maximum RMS current in the primary and secondary windings occurs at 50% duty cycles (minimum input voltage) and maximum output power. Use the following equations to calculate primary and secondary RMS currents:

$$I_{PRMS} = \frac{P_{OUT}}{0.5 \cdot D_{MAX} \cdot \eta \cdot V_{IN(MIN)}} \cdot \sqrt{\frac{D_{MAX}}{3}} \dots (A)$$

$$I_{PRMS} = \frac{1.63 \cdot P_{OUT}}{\eta \cdot V_{IN(MIN)}} \dots (A)$$

$$I_{SRMS} = \frac{I_{OUT}}{0.5 \cdot D_{OFF(MAX)}} \sqrt{\frac{D_{OFF(MAX)}}{3}} \dots (A)$$

$$I_{SRMS} = 1.63 \cdot I_{OUT} \dots (A)$$

Bias current is usually less than 10mA, so the selection of wire thickness depends more on the convenience of winding the wire than its current capacity.

8. The winding technique and sequencing is important in achieving a lower leakage-inductance spike at switch turn-off. As an example, interleave the secondary between two primary halves and keep the bias winding close to the secondary, so the bias voltage follows the output voltage.

MOSFET Selection

Selection criteria for the MOSFET include maximum drain voltage, peak/RMS current in the primary, and maximum-allowable power dissipation for the package (without exceeding the junction temperature limits). Voltage at the MOSFET drain is the sum of the input voltage, the secondary voltage reflected through the transformer turns ratio, and the leakage-inductance spike. (**Figure 2** illustrates the relationship between drain voltage and primary current.) The MOSFET's absolute maximum V_{DS} rating must be higher than the worst-case drain voltage (maximum input voltage and output load).

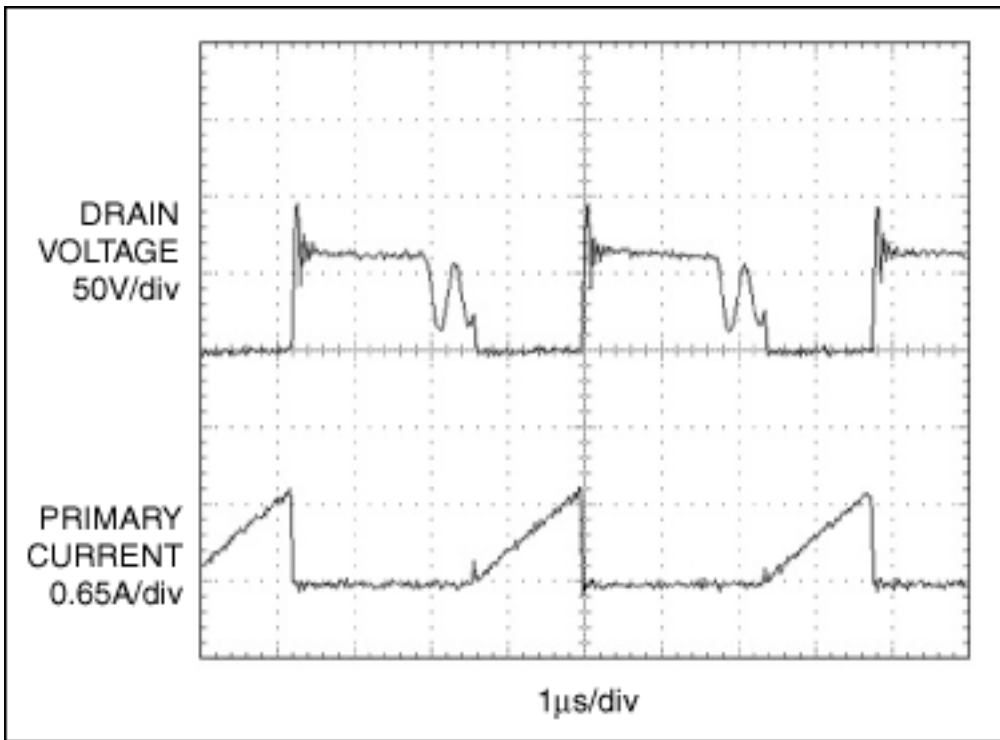

Figure 2. This scope photo shows Figure 1's circuit operating at $V_{IN} = 36V$, $V_{OUT} = 5V$, and $I_{OUT} = 1A$. The switching MOSFET (Q1) exhibits drain voltage (upper trace) at 50V/div, and primary current (lower trace) at 0.65A/div.

$$V_{DS(MAX)} = V_{IN(MAX)} + \frac{N_P}{N_S} \cdot (V_{OUT} + V_D) + V_{SPIKE} \dots (V)$$

A lower V_{DS} Absolute Maximum Rating means a shorter channel, lower $R_{DS(ON)}$, lower gate charge, and a smaller package. Thus, it is advisable to keep $V_{DS(MAX)}$ low by choosing a lower N_P/N_S ratio and keeping the leakage-inductance spike under control. The resistor/capacitor/diode (RCD) snubber network can suppress such spikes.

The RMS current in the primary can be used to calculate DC loss in the MOSFET. Switching loss in the MOSFET depends on the operating frequency, the total gate charge, and the cross-conduction loss during turn off. Cross-conduction loss during turn-on is negligible, because in discontinuous-conduction mode the primary current starts from zero. To avoid damage during power-on and during fault conditions, it may be necessary to derate the MOSFET. Use the following equation to estimate the MOSFET's power dissipation:

$$P_{MOS} = (1.4 \cdot R_{DS(ON)} \cdot I_{PRMS}) + (Q_G \cdot V_{CC} \cdot f_{S(MAX)}) + \frac{(V_{IN(MAX)} \cdot I_{PK} \cdot t_{off} \cdot f_{S(MAX)})}{4} + \frac{(C_{DS} \cdot V_{DS}^2 \cdot f_{S(MAX)})}{2} \dots (W)$$

where:

Q_G = total gate charge of the MOSFET in coulombs;

V_{CC} = bias voltage in volts;

t_{OFF} = turn-off time in seconds;

C_{DS} = drain-to-source capacitance in farads.

RCD Snubber-network Design

To avoid an excessive V_{DS} requirement for the MOSFET, we recommend using an RCD snubber across the primary to suppress the spike caused by energy in the leakage inductance. The snubber dissipates energy that would otherwise dissipate in the MOSFET itself. The snubber capacitor's value should be high enough to absorb the leakage-inductance energy without allowing the MOSFET drain voltage to rise beyond an acceptable limit. Use the following equation to calculate this capacitance:

$$C = \frac{L_L \cdot I_{PK}^2}{V_{SPIKE}^2} \dots (F)$$

where:

L_L = leakage inductance, which should be specified by the transformer vendor. (Values of 1 μ H to 3 μ H are common for the transformer under discussion.)

V_{SPIKE} = spike voltage, typically 30V to 50V.

I_{PK} = peak primary current, which in this case (for a worst-case spike) equals the current-limit threshold divided by R_{SENSE} .

The diode must be a fast-switching type, with reverse-blocking voltage at least equal to the $V_{DS(MAX)}$ rating of the MOSFET. The resistor is selected for an RC time constant 2 to 3 times the switching period. Power dissipation in the resistor is the sum of the leakage inductance energy times frequency, plus the power loss caused by DC bias across the capacitor. The following equation lets you estimate power dissipation in the resistor:

$$P_R = \left(\frac{1}{2} \cdot C_{SNUBBER} \cdot V_{SPIKE}^2 \right) \cdot f_{S(MAX)} + \frac{\left[(V_O + V_D) \cdot \frac{N_P}{N_S} \right]^2 \cdot (1 - D_{MIN})}{R_{SNUBBER}}$$

where:

D_{MIN} = minimum duty cycle = $D_{MAX}/2$. (A 50% derating is recommended for chip resistors.)

Input Filter Design

The input filter reduces the amplitude of AC components in the converter's current pulses, thereby making the converter appear to the source as a DC load. Design parameters for this filter are the RMS ripple-current capability, input voltage, and the allowable level for AC components reflected back to the source.

Because discontinuous-mode flyback converters draw peak triangular currents through the capacitor ESR during each cycle, large aluminum electrolytic capacitors are needed for their low ESR and high ripple-current ratings. Unfortunately for a distributed power system, the input-filter capacitances of parallel converters add together and may produce an unacceptable inrush current at startup. As an alternative, you can use ceramic capacitors to achieve low ESR and a high ripple-current rating while keeping the total capacitance low.

The input peak-to-peak ripple voltage is a combination of the voltage drop due to capacitor ESR (ΔV_{ESR}) and the loss of charge from the capacitor (ΔV_C). For low-ESR ceramic capacitors, use a 3:1 contribution from charge loss and ESR ripple respectively, and use the following equation to estimate capacitance and ESR for the capacitor:

$$C_{IN} = \frac{4 \cdot P_{OUT} \cdot 10^{-6}}{\eta \cdot V_{IN(MIN)} \cdot \Delta V_C} \dots(F)$$

and

$$ESR_{IN} = \frac{\Delta V_{ESR}}{I_{PK}} \dots(\Omega)$$

Choose a capacitor that can handle the necessary RMS ripple without increasing its internal temperature (**Figure 3**). Use the following equation to estimate RMS ripple in the input capacitor:

$$I_{CRMS} = \frac{1.63 \cdot P_{OUT}}{\eta \cdot V_{IN(MIN)}} \dots(A)$$

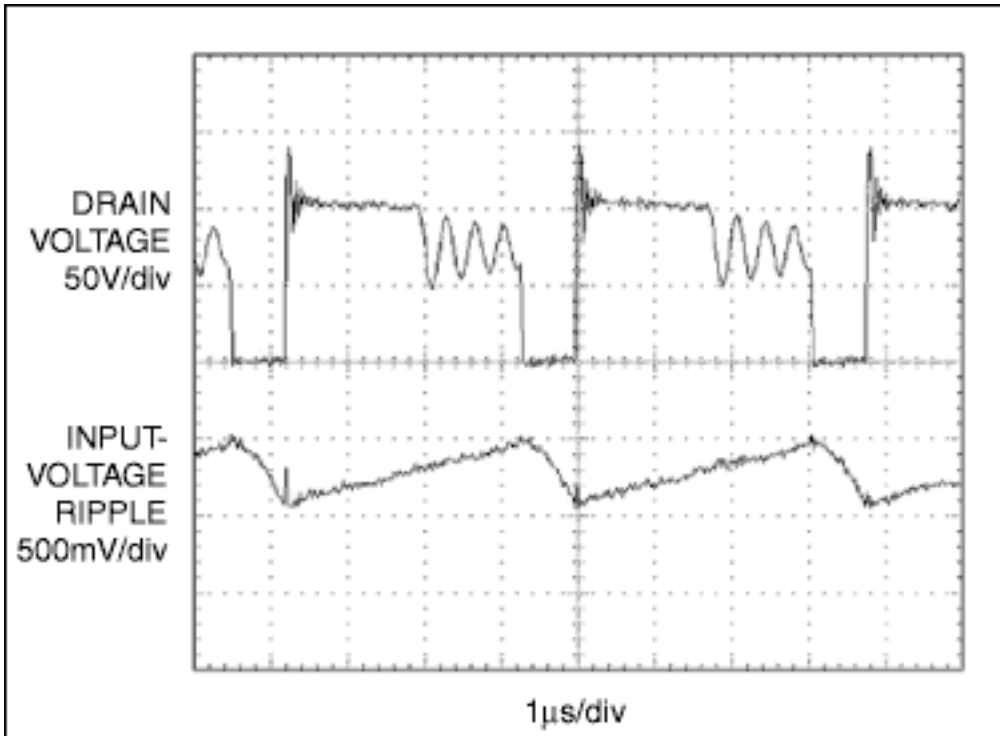

Figure 3. This scope photo shows Figure 1's circuit operating at $V_{IN} = 72V$, $V_{OUT} = 5V$, and $I_{OUT} = 1A$. The circuit exhibits input-voltage ripple at 500mV/div (lower trace), and drain voltage at 50V/div (upper trace).

Output Filter Design

The output capacitance required depends on the level of peak-to-peak ripple acceptable at the load end. The output capacitor for flyback converters supports load current during the switch on-time. The transformer secondary replenishes those lost charges by discharging the core during the off-cycle, and simultaneously supplies the load current. Again, output ripple is the sum of the voltage drop due to the output capacitor's ESR (ΔV_{ESR}), and the charge loss (ΔV_C) during the switch on-time. High switching frequency in the MAX5021 reduces the capacitance requirement. Use low-ESR tantalum capacitors for their favorable combination of capacitance and ESR, and use the following equations to calculate the capacitance and ESR:

$$C_{OUT} = \frac{4 \cdot (1 - D_{OFF}) \cdot I_O \cdot 10^{-6}}{\Delta V_C} \dots(F)$$

and

$$ESR_O = \frac{\Delta V_{ESR}}{I_O} \dots(\Omega)$$

where:

D_{OFF} is the discharge duty cycle, calculated using the following equation:

$$D_{OFF} = \sqrt{\frac{I_O \cdot L_S}{2 \cdot 10^{-6} \cdot (V_O + V_D)}}$$

Additional noise spikes ride on the output ripple, caused by the di/dt of secondary current flowing through the output capacitor's ESL. A small LC filter can suppress these low-energy spikes, and it helps in attenuating switching-frequency ripple as well. To minimize the filter's effect on phase loss and ensure that it does not interfere with compensation, you should design its corner frequency more than one decade away from the estimated closed-loop bandwidth. **Figure 4** shows the peak-to-peak ripple waveforms with and without the LC filter. Use a low-ESR ceramic capacitor of $1\mu F$ to $10\mu F$, and calculate the inductance using the following equation:

$$L \leq \frac{1}{4 \cdot 10^3 \cdot f_C^2 \cdot C} \dots(H)$$

where:

f_C = estimated closed-loop bandwidth.

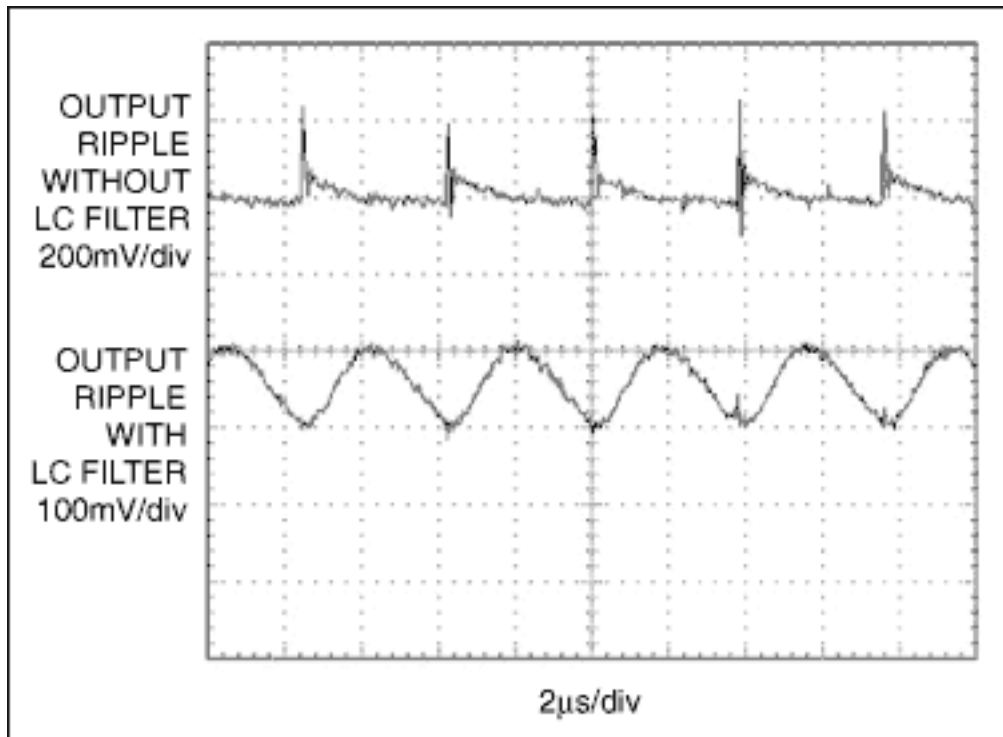

Figure 4. This scope photo shows Figure 1's circuit operating at $V_{IN} = 72V$, $V_{OUT} = 5V$, and $I_{OUT} = 1A$. The circuit has less output-voltage ripple with an LC filter (lower trace at $100mV/div$) than without (upper trace at $200mV/div$).

Power Loss Consideration

High-frequency switching converters can be very lossy, since switching loss simply adds to the DC loss. Careful component selection is necessary to keep switching loss at a minimum. The MAX5021 is designed to operate at a sufficiently high frequency to reduce the size of passive components while minimizing switching losses. The MAX5021's low startup current and low-quiescent operating current minimize power loss in the control circuitry. To reduce switching loss even further and achieve higher converter efficiency, use a MOSFET with low gate charge and low gate-to-drain capacitance, and balance the MOSFET's DC and switching-power losses. See graph of Converter Efficiency vs. Output Current (**Figure 5**), and use the following equation to calculate DC and switching losses in MOSFET:

$$P_{MOS} = (1.4R_{DS(ON)} \cdot I_{PRMS}) + (Q_G \cdot f_{SW} \cdot V_{CC}) + \left(\frac{I_{PK} \cdot V_D \cdot t_f \cdot f_{SW}}{6} \right)$$

where:

Q_G = total gate charge for the MOSFET in nanocoulombs;

V_{CC} = voltage at V_{CC} (pin 4 of MAX5021);

t_f = turn-off time in seconds;

V_D = drain voltage at turn-off in volts;

f_{SW} = switching frequency (262kHz);

i_{PK} = primary peak current in amperes.

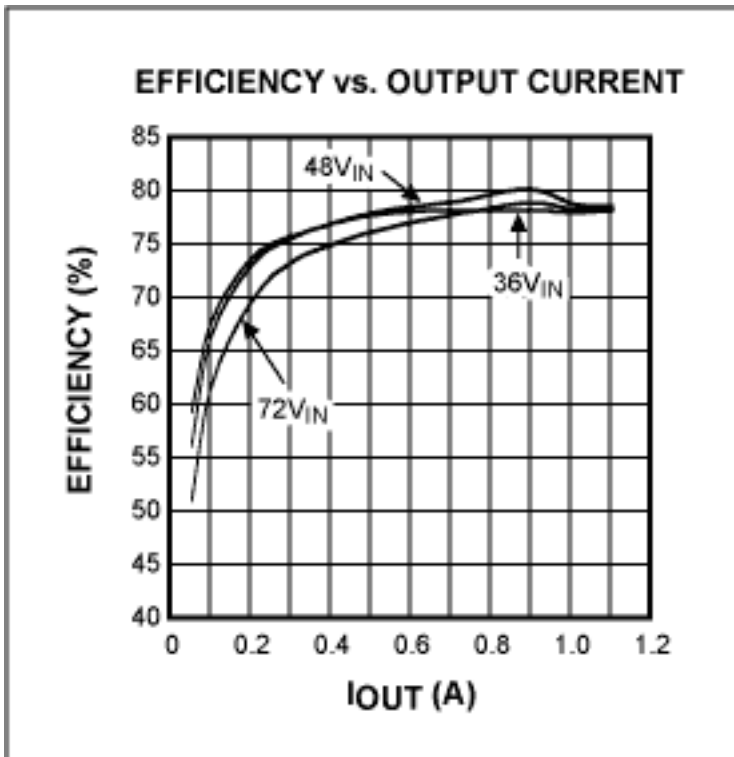

Figure 5. The graph demonstrates Efficiency vs. Output Current curves for the circuit in Figure 1.

Use a Schottky diode in the secondary to achieve low V_{DS} and low reverse-recovery loss. Use the following equation to calculate DC loss in the secondary diode while neglecting reverse-recovery loss due to switching:

$$P_D = V_{FB} \cdot I_O$$

where:

V_{FB} = forward drop for the secondary diode at $I_{SPK}/2$, in volts.

You can reduce the transformer-leakage inductance between primary and secondary by sandwiching the secondary between two halves of the primary. Use a multifilar winding structure to reduce skin-effect loss.

Frequency Compensation

The absence of a right-half-plane (RHP) zero in the discontinuous flyback converter simplifies the closed-loop frequency compensation to a single pole-zero pair. No bandwidth limit arises from the location of the RHP zero. The loop is closed through the shunt regulator, optocoupler, and PWM comparator internal to the MAX5021. The location of the error amplifier's pole and zero is determined from the existing PWM gain, the output-filter pole, and the ESR zero frequency. Use the following equations to calculate the current-mode converter's PWM gain, the output-capacitor filter pole, and the output capacitor's ESR zero:

$$A_{PWM} = \frac{\sqrt{\frac{R_L \cdot L_P \cdot f_{SW} \cdot \eta}{2}}}{R_S} \cdot \frac{6.2 \cdot 10^3}{R_{LED}} \cdot CTR$$

$$A_{PWM} = \frac{\sqrt{\frac{5 \cdot 61 \cdot 10^{-6} \cdot 262 \cdot 10^3 \cdot 0.8}{2}}}{0.65} \cdot \frac{6.2 \cdot 10^3}{510} \cdot 1$$

$$A_{PWM} = 105$$

Capacitor filter pole (f_p):

$$f_p = \frac{1}{2 \cdot \pi \cdot R_L \cdot C_O} \dots(\text{Hz})$$

$$f_p = \frac{1}{2 \cdot \pi \cdot 5 \cdot 330 \cdot 10^{-6}} \dots(\text{Hz})$$

$$f_p = 96 \dots(\text{Hz})$$

Capacitor ESR zero (f_z):

$$f_z = \frac{1}{2 \cdot \pi \cdot C_O \cdot ESR} \dots(\text{Hz})$$

$$f_z = \frac{1}{2 \cdot \pi \cdot 330 \cdot 10^{-6} \cdot 0.06} \dots(\text{Hz})$$

$$f_z = 8038 \dots(\text{Hz})$$

where:

R_L = load resistance;

CTR = current-transfer ratio of optocoupler;

R_S = current-sense resistor in the primary path; and

C_O = output-filter capacitor.

Total loop gain equals the PWM gain (A_{PWM}) times the gain of the voltage divider and the error amplifier (shunt regulator). The available worst-case phase margin (PM) occurs at full load.

The response of the combined-error amplifier, optocoupler and PWM is too complicated to estimate analytically. You should therefore use the existing compensation network to plot a Bode diagram of the closed-loop transfer

function from control to output. Then place the zero and pole at appropriate locations for maximum "phase bump" at the crossover frequency. To maintain a gain slope of -1 to well beyond the crossover frequency, place the error-amplifier pole at the ESR zero location. Use the following equations to calculate the zero (f_{ZE}) and poles (f_{PE}) of the error amplifier:

$$f_{ZE} = \frac{1}{2 \cdot \pi \cdot R_f \cdot C_f} \dots (\text{Hz})$$

$$f_{ZE} = \frac{1}{2 \cdot \pi \cdot 47 \cdot 10^3 \cdot 10 \cdot 10^{-9}} \dots (\text{Hz})$$

$$f_{ZE} = 338 \dots (\text{Hz})$$

$$f_{PE} = \frac{1}{2 \cdot \pi \cdot R_f \cdot C_{ff}} \dots (\text{Hz})$$

$$f_{PE} = \frac{1}{2 \cdot \pi \cdot 47 \cdot 10^3 \cdot 220 \cdot 10^{-12}} \dots (\text{Hz})$$

$$f_{PE} = 15,392 \dots (\text{Hz})$$

Optimization on the board produces a closed-loop bandwidth of 8kHz with 44° of phase margin. The Bode plot of **Figure 6** is based on the circuit of Figure 1, with values as shown for the compensation components.

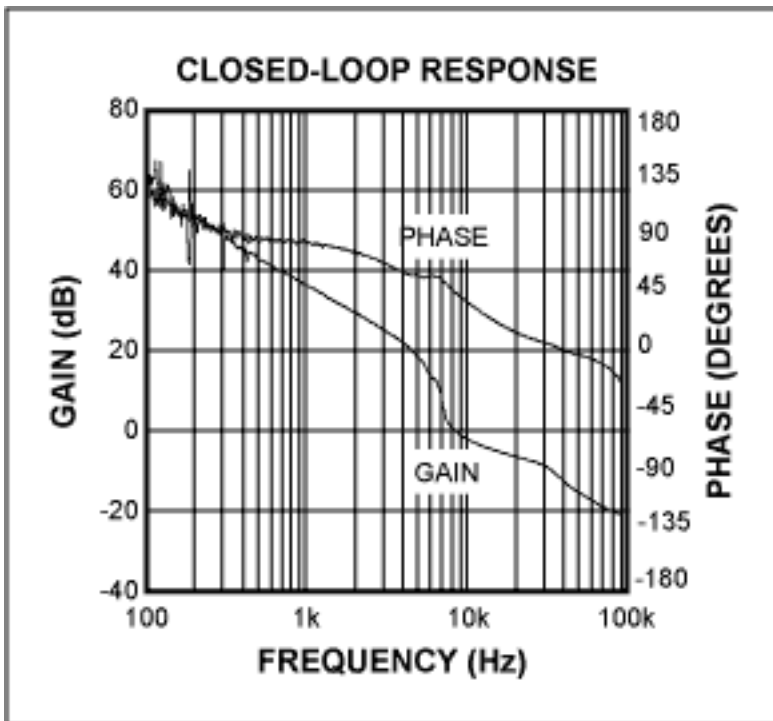

Figure 6. This Bode plot illustrates stability for the Figure 1's circuit operating with component values as shown.

We can verify the load-transient response for a small-deviation, fast-settling perturbation in the output voltage by switching the load from 100mA to 1A in 20 μ s (**Figure 7**). An overcompensated converter increases the response time, which may also cause an output overshoot during turn-on. **Figure 8** depicts the result of an optimally compensated loop.

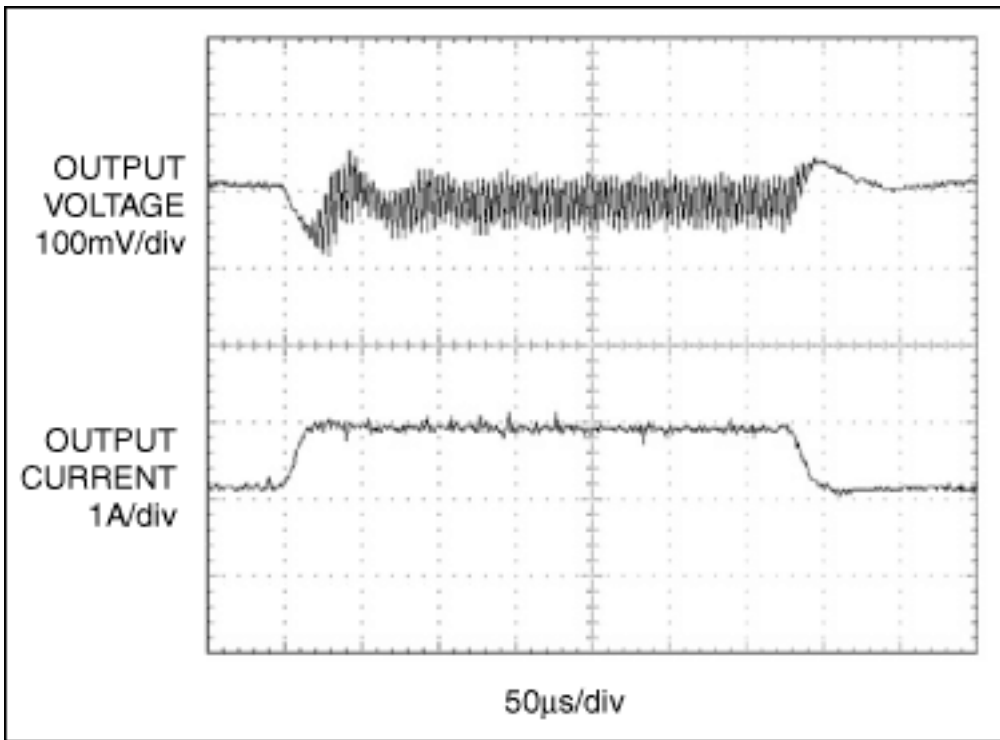

Figure 7. The transient response for the Figure 1's circuit: I_{OUT} at 1A/div (lower trace), and V_{OUT} at 100mV/div (upper trace).

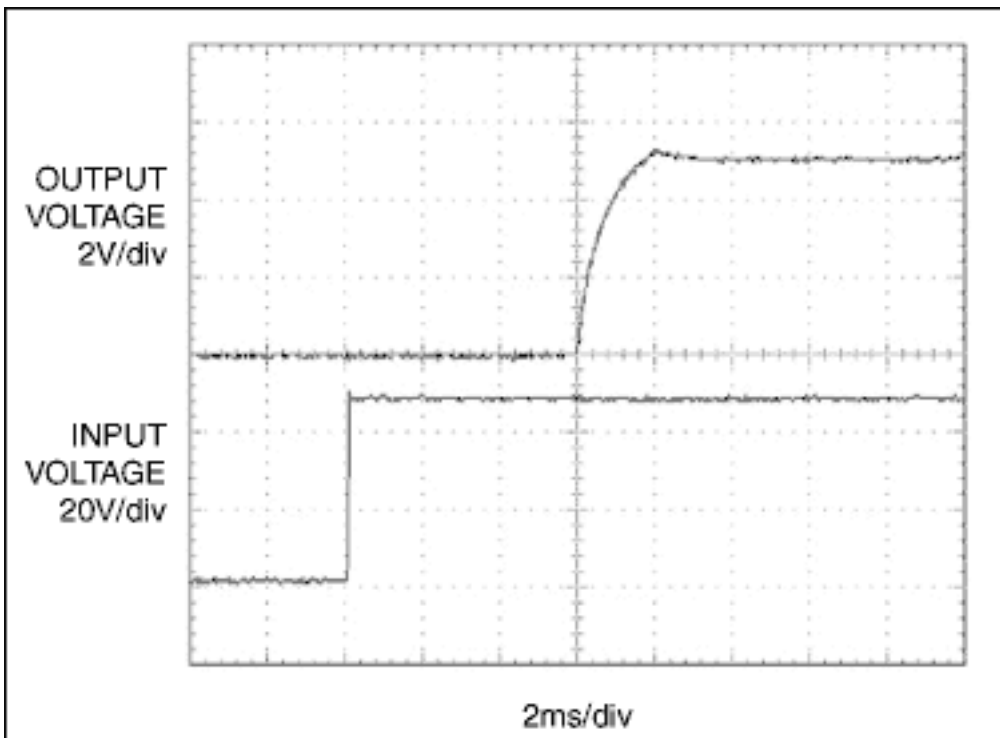

Figure 8. These startup waveforms appear in the Figure 1's circuit with an optimally compensated loop. The circuit has 48V input voltage at 20V/div (lower trace), and 5V output voltage with 1A load at 2V/div (upper trace).

Layout and Safety Guidelines

High-frequency switching converters produce current and voltage waveforms with high slew rates. To minimize voltage spikes and electromagnetic radiation, you should minimize inductance in the current loops and PC traces. Component placement is critical in keeping the high-frequency traces short. Follow the steps below for good layout:

- Minimize the loop formed by the input capacitor positive terminal, transformer primary, MOSFET switch, current-sense resistor, and input-capacitor negative terminal.
- Keep the gate-drive trace from the MAX5021 to the switching MOSFET short.
- Place the RCD snubber components close to the input capacitor and MOSFET switch.
- Place the ceramic capacitors connected to the MAX5021 V_{CC} , V_{IN} , and CS pins close to the IC.
- Minimize the loop formed by the transformer secondary, secondary diode, and output capacitor.
- For effective heatsinking on the PC board, connect a large copper area to the MOSFET drain, transformer secondary, and secondary diode.

The type of circuit (SELV, TNV-1, TNV-2, or TNV-3) and its degree of pollution (determined by the circuit surroundings) determine the requirements for clearance and creepage between the primary and secondary circuits. For the minimum clearance and creepage distances between different circuit components, contact your safety engineer or refer to Underwriters Laboratory standard UL60950.

Appendix - Transformer Design

Given the specifications $V_{IN} = 36V$ to $72V$, $V_{OUT} = 5.1V$, and $I_{OUT} = 1.1A$, proceed as follows:

Step 1. Area product (A_p):

$$A_p \geq \frac{(2 \cdot P_{OUT}) \cdot 10^{-12}}{\eta \cdot B_{MAX}} \dots (m^4)$$

$$A_p \geq \frac{(2 \cdot 5.61) \cdot 10^{-12}}{0.8 \cdot 0.12} \dots (m^4)$$

$$A_p \geq 117 \cdot 10^{-12} \dots (m^4)$$

Select EPC13 (TDK Part Number ? PC44EPC13-Z)
Core A_p and A_e :

$$A_p = 145 \cdot 10^{-12} \dots (m^4)$$

$$A_e = 12.5 \cdot 10^{-6} \dots (m^2)$$

Step 2. Secondary inductance (L_s):

$$L_s \leq \frac{430 \cdot 10^{-9} \cdot (V_O + V_D)}{I_{OUT}} \dots (H)$$

$$L_s \leq \frac{430 \cdot 10^{-9} \cdot (5.1 + 0.4)}{1.1} \dots (H)$$

$$L_s \leq 2.15 \cdot 10^{-6} \dots (H)$$

Step 3. Primary inductance (L_p):

$$L_P = \frac{0.4 \cdot 10^{-6} \cdot V_{IN(MIN)}^2 \cdot \eta}{P_{OUT}} \dots(H)$$

$$L_P = \frac{0.4 \cdot 10^{-6} \cdot 34^2 \cdot 0.8}{5.6} \dots(H)$$

$$L_P = 65 \cdot 10^{-6} \dots(H)$$

Step 4. Primary turns (N_P):

$$N_P = \frac{2.1 \cdot 10^{-6} \cdot V_{IN(MIN)}}{A_e \cdot B_{MAX}} \dots(T)$$

$$N_P = \frac{2.1 \cdot 10^{-6} \cdot 36}{12.5 \cdot 10^{-6} \cdot 0.12} \dots(T)$$

$$N_P = 47.6 \dots(T)$$

Round off the primary turns, $N_P = 48t$.

Step 5. Secondary- and bias-winding turns (N_S and N_{bias}):

$$N_S = N_P \cdot \sqrt{\frac{L_S}{L_P}} \dots(T)$$

$$N_S = 8.7 \dots(T)$$

Round off the secondary turns, $N_S = 9t$:

$$N_{bias} = \frac{11.7}{V_{OUT} + 0.2} \cdot N_S$$

$$N_{bias} = 19.8$$

Round off the bias-winding turns, $N_{bias} = 20t$.

Step 6. Value of the core:

$$A_L = \frac{L_P}{N_P^2} \cdot 10^9 \dots \frac{nH}{T^2}$$

$$A_L = 26 \dots \frac{nH}{T^2}$$

Step 7. Primary and secondary RMS currents (I_{PRMS} and I_{SRMS}):

$$I_{PRMS} = \frac{1.63 \cdot P_{OUT}}{\eta \cdot V_{IN(MIN)}} \dots(A)$$

$$I_{PRMS} = \frac{1.63 \cdot 5.1 \cdot 1.1}{0.8 \cdot 34} \dots(A)$$

$$I_{PRMS} = 0.33 \dots(A)$$

$$I_{SRMS} = 1.63 \cdot I_{OUT} \dots(A)$$

$$I_{SRMS} = 1.79 \dots(A)$$

Application Note 1062: <http://www.maxim-ic.com/an1062>

More Information

For technical questions and support: <http://www.maxim-ic.com/support>

For samples: <http://www.maxim-ic.com/samples>

Other questions and comments: <http://www.maxim-ic.com/contact>

Related Parts

MAX5021: [QuickView](#) -- [Full \(PDF\) Data Sheet](#) -- [Free Samples](#)

MAX5022: [QuickView](#) -- [Full \(PDF\) Data Sheet](#) -- [Free Samples](#)

AN1062, AN 1062, APP1062, Appnote1062, Appnote 1062

Copyright © by Maxim Integrated Products

Additional legal notices: <http://www.maxim-ic.com/legal>