



APPLICATION NOTE 1044

Design of Graphic Chip and Related Circuitry Power Supplies Using MAX1953 1MHz PWM Step-down Controller

Abstract: Powerful graphic chips are prevalent in personal computers and gaming consoles. Power supply requirements for the graphic processors and supporting circuitry are extremely critical from a cost-performance point of view. In this article we present graphic card power supply solutions using MAX1953 1MHz pulse-width modulator (PWM) step-down controller.

Powerful graphic chips are prevalent in personal computers and gaming consoles. In games, presentations, and web surfing, 3D graphics now take center stage and a host of third-generation 3D-chips are arriving to deliver another quantum leap in 3D-performance and video quality over anything seen to date. Fill rates of greater than 500-600 Mpixel/s, triangle rates of 20 million/s, as well as the support of other enhancements will ask a lot more from game developers, CPUs, memory, RAMDACs and even display technologies. Additionally, the power supply requirements for graphic processors and the supporting circuitry have also increased dramatically.

Power supply requirements for the graphic processors and supporting circuitry are extremely critical from a cost-performance point of view. In this article we present graphic card power supply solutions.

- AGP terminations for input power:
 - - 3.3V @ 6A → = 18.9W
 - - 5.0V @ 2A → = 10.0W
 - - 12.0V @ 1A → = 12.0W
- Typical Power Supply Requirements:

Table 1.

	Voltage	Current	Solution
GPU (Graphic Processing Unit)	1.2V or 1.5V	5A	MAX1953
DDR Memory (VDDQ)	2.5V	3A	MAX1953

- Typically inexpensive solutions are required with need for some generic failure features such controlled soft start, UVLO and current limiting.

Below are several step-down solutions using the MAX1953 to generate the supply voltages listed in the table above, that features:

- Single SO-8 package dual N channel MOSFET
- No current sense resistor
- Low input voltage operation (3.3V and 5V rails)
- 1 MHz switching for small size, low cost
- Efficiency >90%

Figure 1 shows the step-down solution for the GPU and **Figure 2** shows the solution for the DDR memory main voltage regulation.

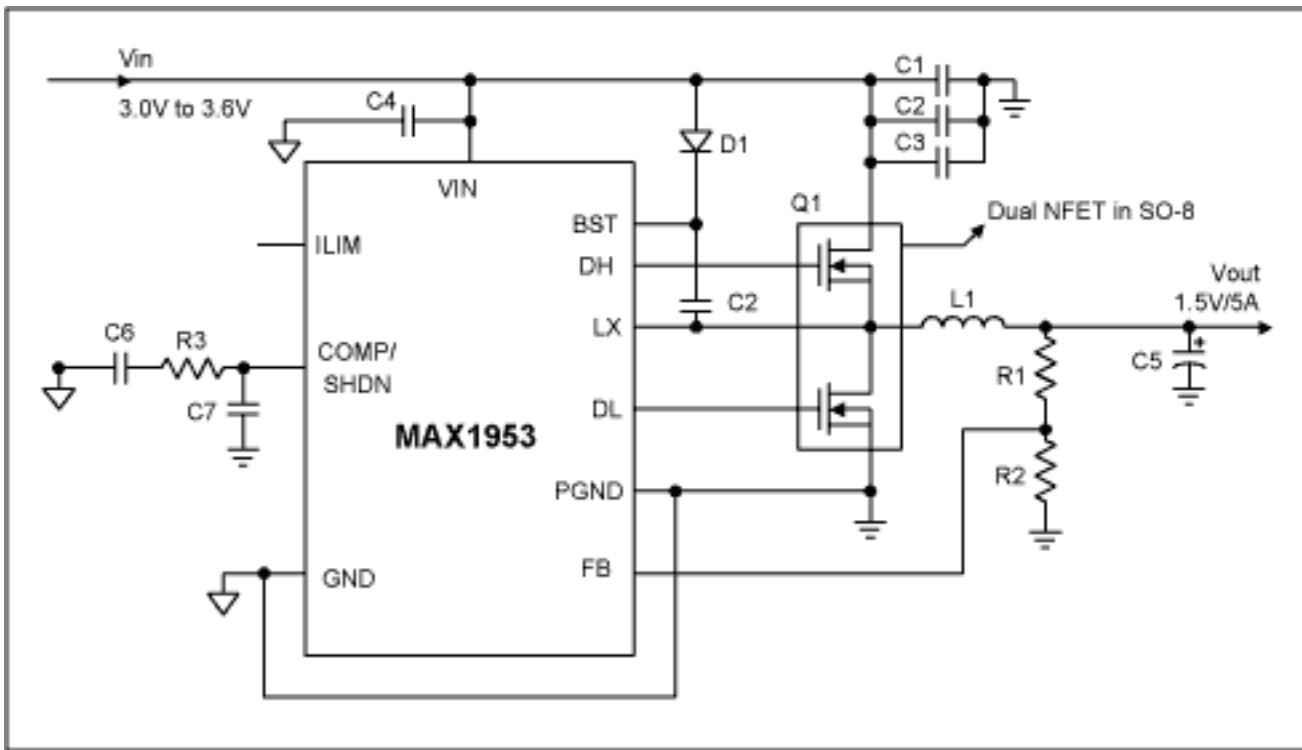

Figure 1. The MAX1953: 1MHz switching, 1.5V/5A GPU supply, 3.3V In, 1.5V/5A out.

Table 2. Component List for 3.3V in, 1.5V/5A Output at MHz.

Component ID	Quantity	Description
C1, 2, 3, 4	4	Cap. 10 μ F/6.3V Cer 0805 Taiyo Yuden:JMK212F106ZG
C5	1	Cap. 180 μ F/4V. Panasonic: EEFUE0G181R
C6	1	Cap. 680pF/10V Cer 0402 Kemet: C0402C681M8RAC
C7	1	Cap. 39pF/10V Cer 0402 Kemet: C0402C390K8GAC
D1	1	Diode, Schottky, 40V, 1A, SOT-23F, Central: CMPSH1-4
IC	1	IC, Synch. Buck controller: MAX1953
L1	1	Inductor, 0.68 μ H, 12A, 5m Ω . Coilcraft: DO3316P-681HC
R1	1	Resistor, 7.15K, 1%, 0603 case
R2	1	Resistor, 8.06K, 1%, 0603 case
R3	1	Resistor, 82K, 5%, 0603 case
Q1/2	1	Transistor, Dual MOSFET, Fairchild: FDS6898A, 20V, 0.013 Ω

Note: For 1.2V output, change R1 to 4.12K, 1%, and R3 to 68K, 5%.

Figure 2 shows the plot of efficiency versus output current of the 1.5V, 5A circuit.

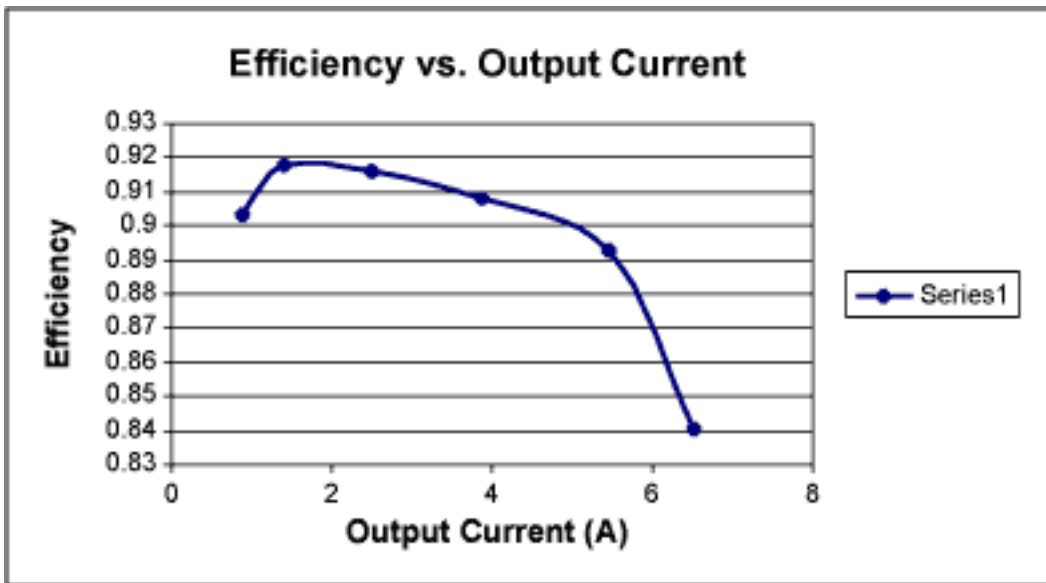

Figure 2.

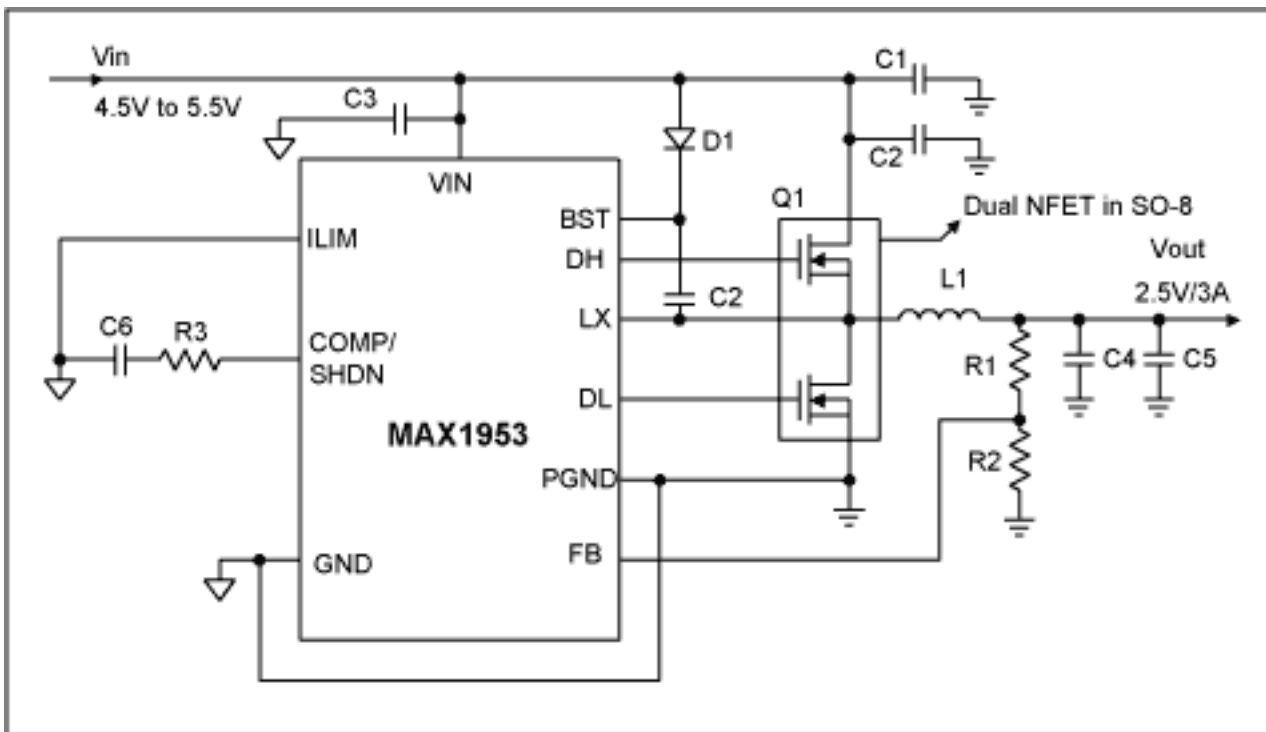

Figure 3. The MAX1953: 1MHz switching, 2.5V/3A memory VDDQ supply.

Table 3. Component List for 5V in, 2.5V/3A Output at 1MHz.

Component ID	Quantity	Description
C1, 2, 3	3	Cap. 10 μ F/6.3V Cer 0805 Taiyo Yuden: JMK212F106ZG
C4, 5	2	Cap. 10 μ F/4V Cer 0805 Taiyo Yuden: AMK212BJ106MG
C6	1	Cap. 560pF/10V Cer 0402 Kemet: C0402C561M8RAC
D1	1	Diode, Schottky, 40V, 1A, SOT-23F, Central: CMPSH1-4
IC	1	IC, Synch. Buck controller: MAX1953
L1	1	Inductor, 1.5 μ H, 3.4A, 30m Ω : Toko# 817FY-1R5M
R1	1	Resistor, 17.4K, 1%, 0603 case
R2	1	Resistor, 8.06K, 1%, 0603 case
R3	1	Resistor, 33K, 5%, 0603 case
Q1/2	1	Transistor, Dual MOSFET, Fairchild: FDS6898A, 20V, 0.013 Ω

Figure 4 shows the plot of efficiency vs. output current for the 2.5V, 3A circuit.

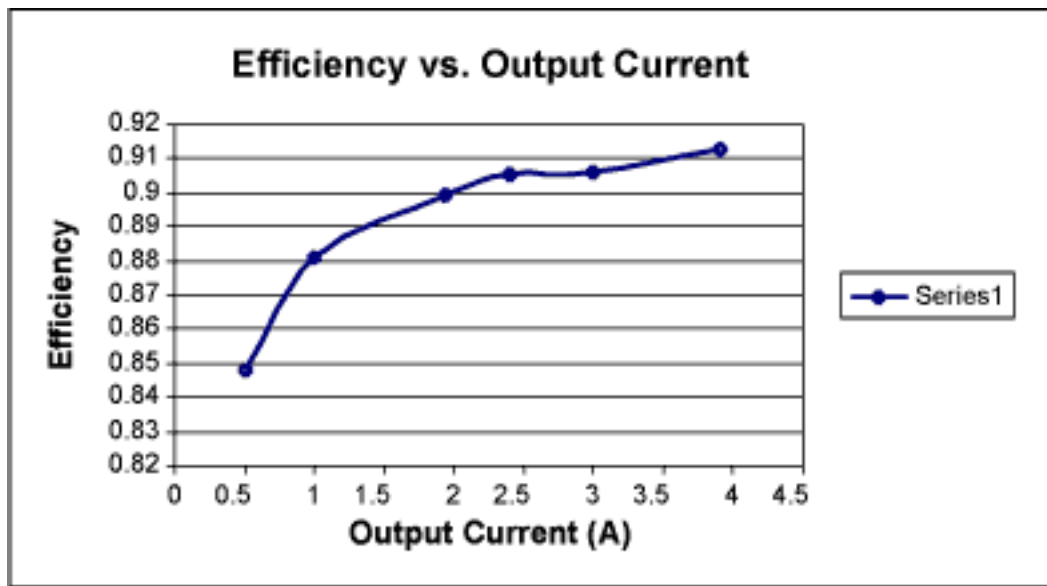

Figure 4.

The above circuits show that the MAX1953 can be used to generate both the GPU and the memory supply rails for graphic cards. The capability of operating down to 3V input of the MAX1953 allows the total output power to be drawn from both input supplies, 3.3V and 5V, so that neither of these rails is overloaded. The 1MHz switching frequency helps reduce filter inductor and capacitors size and cost.

Application Note 1044: <http://www.maxim-ic.com/an1044>

More Information

For technical questions and support: <http://www.maxim-ic.com/support>

For samples: <http://www.maxim-ic.com/samples>

Other questions and comments: <http://www.maxim-ic.com/contact>

Related Parts

MAX1953: [QuickView](#) -- [Full \(PDF\) Data Sheet](#) -- [Free Samples](#)

AN1044, AN 1044, APP1044, Appnote1044, Appnote 1044

Copyright © by Maxim Integrated Products

Additional legal notices: <http://www.maxim-ic.com/legal>