



APPLICATION NOTE 1043

Single Supply Sequencer Sequences Negative Voltages

Abstract: The following application note discusses how to sequence a positive then negative power supply using the MAX6819/MAX6820 power supply sequencers.

Highly integrated system chips that combine multiple digital and analog functions into a single die often require multiple power supplies. Improper supply sequencing can lead to device latchup, incorrect device initiation, or degradation of long-term reliability. The MAX6819/MAX6820 provide a simple, reliable, and compact way to sequence two or more power supplies.

Unfortunately, the MAX6819/MAX6820 are single supply devices, and are unable to sequence voltages below device ground. The MAX6819/MAX6820 use an external N-channel MOSFET to switch the secondary supply to and from the circuit. The MOSFET gate drive, GATE, swings between $V_{CC2} + 5.5V$ and GND, thus, with a negative supply voltage, the MOSFET cannot be turned off. **Figure 1** shows an example of the MAX6819/MAX6820 employed in a $\pm 5V$ supply circuit.

When the main supply (V_{CC1}) is below the switchover threshold, GATE is driven to GND. The 7.5V zener diode (D1) does not conduct, allowing resistor R1 to pull the gate of the MOSFET to the negative supply. This results in $V_{GS} = 0$, disabling the MOSFET. Once V_{CC1} exceeds the switchover threshold, GATE drives high. With $V_{CC1} = V_{CC2} = +5V$, $V_{GATE(HIGH)} = +10.5V$. With the 7.5V drop across D1, $V_G = +3V$, providing a $V_{GS} = +8V$. A 7.5V zener diode was chosen because it provided 8V of gate drive, sufficiently minimizing the IR drop across the MOSFET. R_{ON} can be further reduced by selecting a lower voltage zener, however, be aware of the GATE current. Size R1 such that the resulting V_{GS} does not lead to a GATE current draw greater than 5 μA . A larger load will lower $V_{GATE(HIGH)}$, degrading the device's ability to fully enhance the MOSFET.

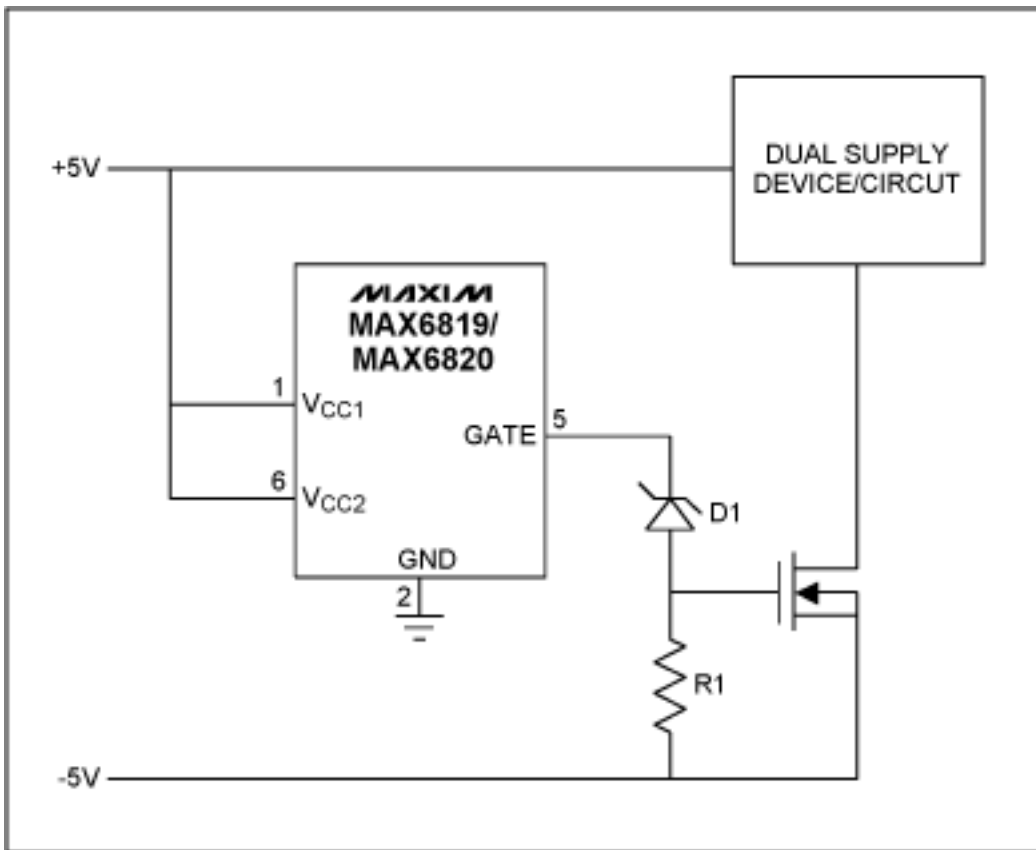

Figure 1. Single-supply, positive/negative voltage sequencer.

Application Note 1043: <http://www.maxim-ic.com/an1043>

More Information

For technical questions and support: <http://www.maxim-ic.com/support>

For samples: <http://www.maxim-ic.com/samples>

Other questions and comments: <http://www.maxim-ic.com/contact>

Related Parts

MAX6819: [QuickView](#) -- [Full \(PDF\) Data Sheet](#) -- [Free Samples](#)

MAX6820: [QuickView](#) -- [Full \(PDF\) Data Sheet](#) -- [Free Samples](#)

AN1043, AN 1043, APP1043, Appnote1043, Appnote 1043

Copyright © by Maxim Integrated Products

Additional legal notices: <http://www.maxim-ic.com/legal>