

Keywords: single, SCART, video applications, TV, Europe, PAL, integrated circuits, ICs, scart interfaces, switching

Mar 28, 2002

APPLICATION NOTE 1024

A Single SCART Interface for Video

In many SCART applications, specialized ICs are used for the SCART interface because of the complicated switching required. This is not cost effective for single SCART implementations.

The circuits described in this application note are alternative methods that provide high quality SCART interfaces without adding switches or a mux.

In Europe, the external connections to TVs, set-top boxes, VCRs and other video peripherals are provided by a SCART, or *Peritel*, connector. Its pin-out is specified in EN50049. Depending on the SCART connector's use (TV SCART, AUX SCART, or VCR SCART) the connector is an input, an output, or both.

The addition of S-VHS complicated this interface by requiring the RED and Cvbs pins (15 and 20) to be shared with the Chroma (C) and Luma (Y) pins.

In most cases, specialized ICs are used for the SCART interface because of the complicated switching required. But this is not cost effective for smaller, unidirectional implementations.

The simplest form is the single SCART switch found on the TV's input and encoder's outputs. The circuits below are an alternative method that provides a high quality interface without adding switches or a mux.

Here, the enable function of the MAX4384 quad video op-amp is used to multiplex the R/Chroma and Cvbs/Luma formats, and buffer them, and a MAX4451 dual video op-amp buffers the BLUE and GREEN. **Figure 1** shows this as an output SCART, **Figure 2**, as an input SCART, and **Figure 3**, as a bi-directional SCART.

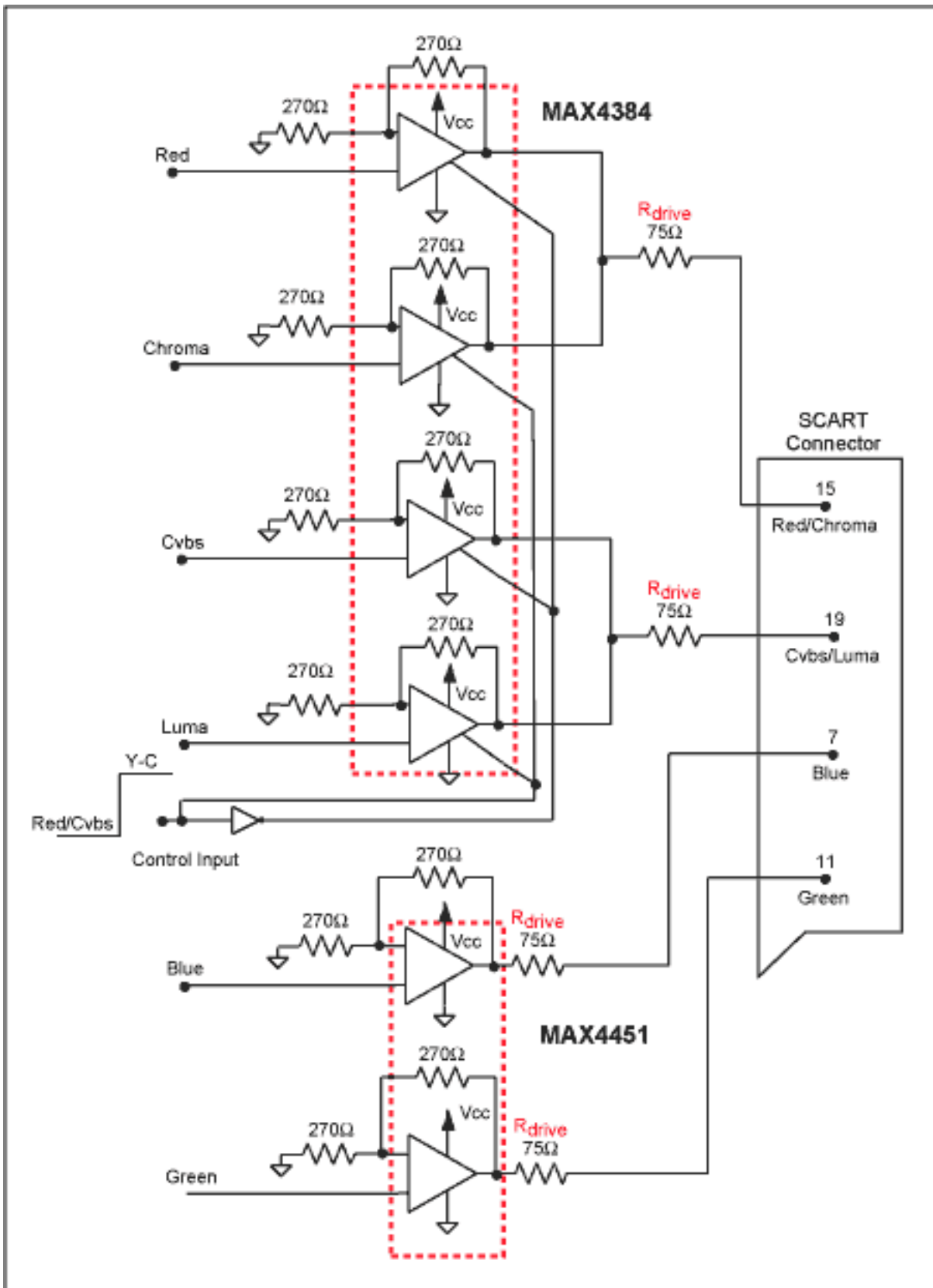

Figure 1. Output SCART using the MAX4384 and MAX4451.

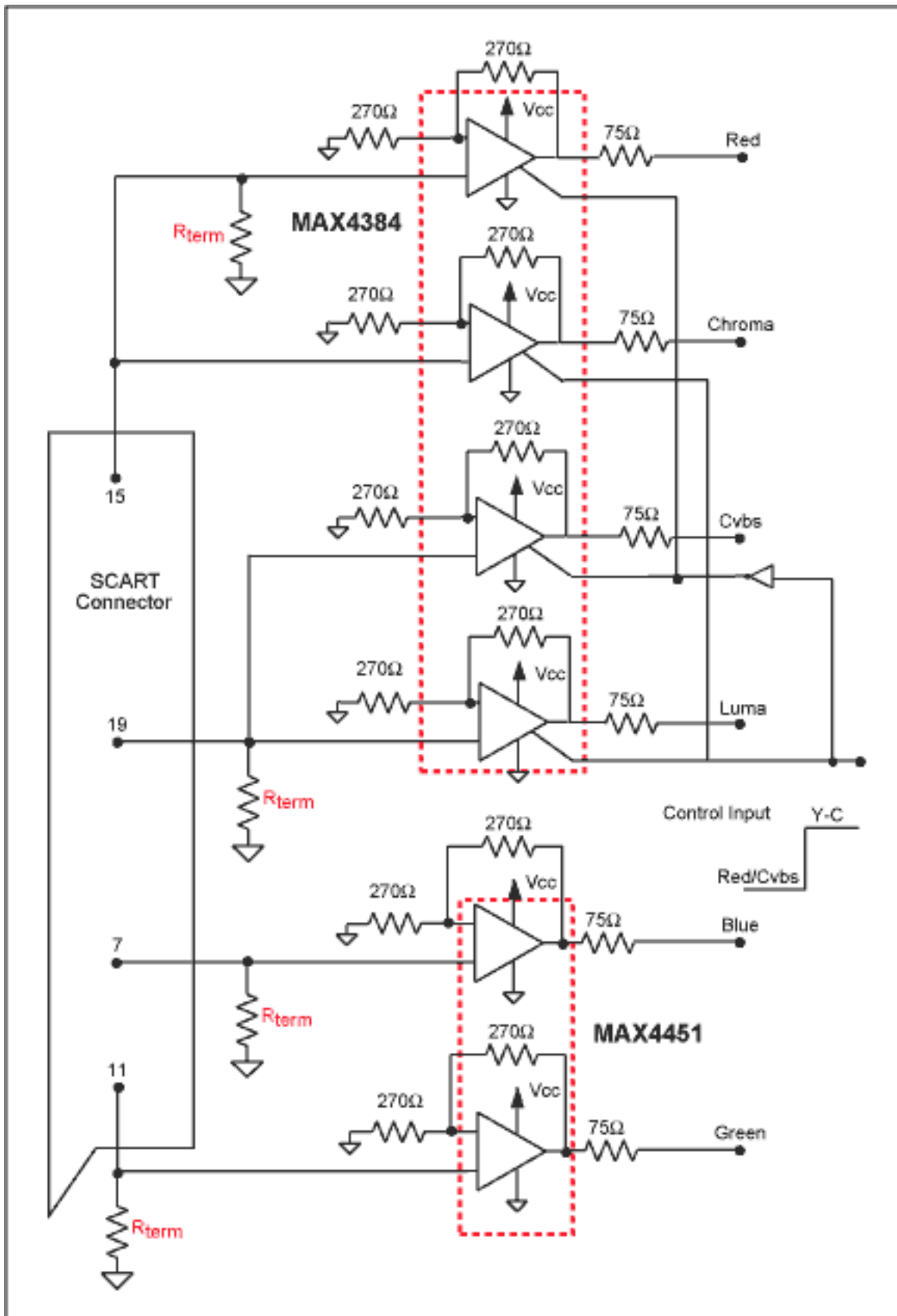

Figure 2. Input SCART using the MAX4384 and MAX4451.

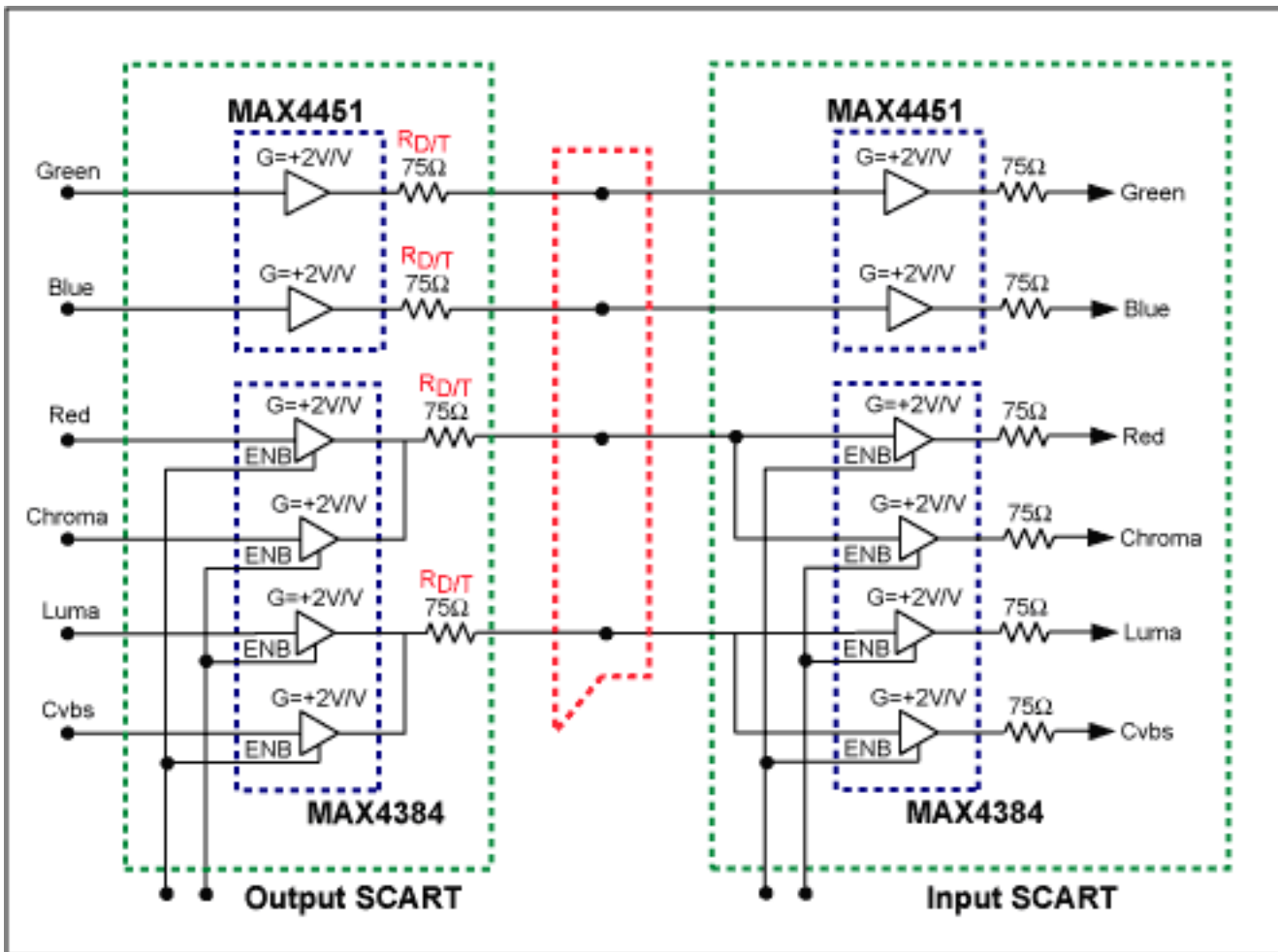

Figure 3. Bi-directional SCART.

The circuit design for the MAX4384 and the MAX4451 is straight forward. They are configured with a non-inverting gain of two, using equal values of input and feedback resistance. The resistor's values shouldn't be so large that they create an in-band pole, nor so small that they can't be driven linearly. For the input or output SCART, the enable pins of the Chroma/Luma can be inverted and tied to the Red/Cvbs enable for single pin control, while separate resistors (R_{drive} and R_{term}) are used for the drive and termination. The bi-directional SCART in Figure 3 uses the output SCART drive resistors (R_{drive}) for the input SCART terminations (R_{term}) by enabling the output SCART section with its inputs grounded, thereby connecting $R_{D/T}$ to ground through the Op-Amps output. Typically, the output SCART is driven from a DAC, so simply disabling it will pull all the inputs to ground.

Since dedicated, multi-input, SCART switches don't include the Y/Cvbs and C/Red multiplexing, the MAX4384 portion of the input or output SCART design can be used with these parts to implement it externally.

The audio portion of the SCART interface can be implemented using the MAX4493-MAX4495 family of audio op-amps as either a stereo pair or a monaural mix of the L and R channels to complete the design.

Application Note 1024: <http://www.maxim-ic.com/an1024>

More Information

For technical questions and support: <http://www.maxim-ic.com/support>

For samples: <http://www.maxim-ic.com/samples>

Other questions and comments: <http://www.maxim-ic.com/contact>

Related Parts

MAX4384: [QuickView](#) -- [Full \(PDF\) Data Sheet](#) -- [Free Samples](#)

MAX4451: [QuickView](#) -- [Full \(PDF\) Data Sheet](#) -- [Free Samples](#)

AN1024, AN 1024, APP1024, Appnote1024, Appnote 1024

Copyright © 2005 by Maxim Integrated Products

Additional legal notices: <http://www.maxim-ic.com/legal>