



APPLICATION NOTE 1018

How to Modify an Existing Design from a TDA5200 or TDA5201 to a MAX1470 Superheterodyne Receiver

Abstract: This application note covers the step-by-step procedure required to replace the TDA5200 or TDA5201 in a design with the MAX1470 superheterodyne receiver

If you have been looking into modifying your existing Infineon receiver board with a MAX1470 to take advantage of its unique features, this app note is for you. **Figure 1** shows a typical TDA5200/TDA5201 based circuit tuned to receive 433.92MHz signals, and the four simple steps needed to upgrade this TDA5200/TDA5201 receiver board to the MAX1470.

Equipment/components needed:

- Your assembled receiver board
- A soldering iron
- A MAX1470 IC
- A 6.6128MHZ (433.92MHz operation) or a 4.7547MHz (315MHz operation) crystal
- 2x100pF and 1x3.0pF capacitors for 433.92MHz or 2x100pF and 1x4.7pF capacitors for 315MHz operation
- 1x68nH, and 2x15nH inductors for 433.92MHz or 1x15nH, 1x27nH, and 1x120nH inductors for 315MHz operation

Or call (408)737-7600x6503 and request a conversion kit. Please specify frequency of operation.

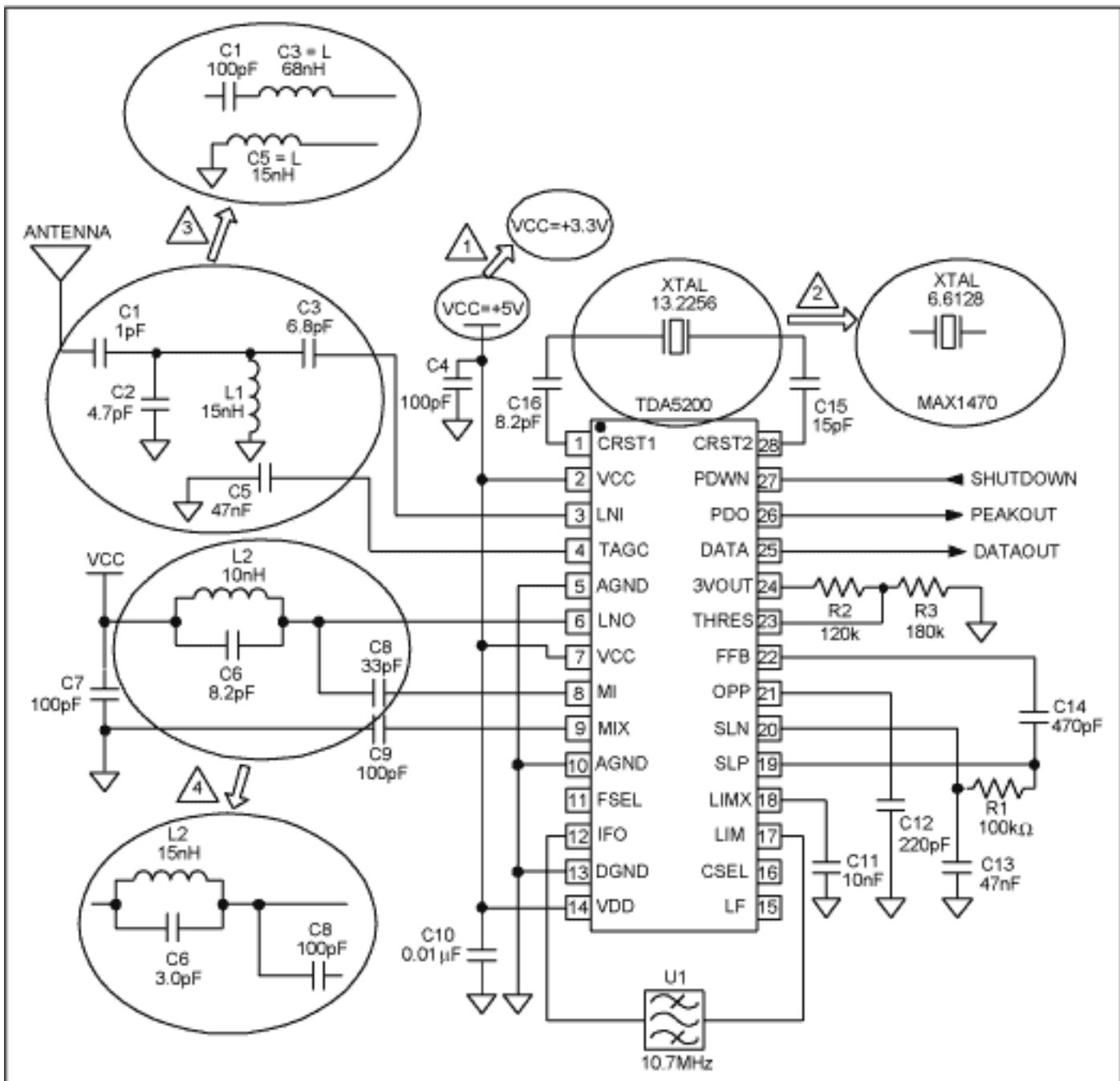

Figure 1. Typical TDA5200 based circuit (433.92MHz) and the four conversion steps.

The four simple steps for this conversion are described here:

1. **Supply voltage:** The MAX1470 requires a 3.3V supply. Care must then be taken not to connect the TDA's 5V supply to the MAX1470 based circuit.
2. **IC and XTAL oscillator:** Replace the TDA5200 with the MAX1470. The MAX1470 PLL uses a 64x clock divider which forces the XTAL to be 6.6128MHz for a 433.92MHz receive frequency. Depending on the crystal used, capacitors C15 and C16 may have to be different, to compensate for the crystal being pulled away from its stated operating frequency due to the difference in load capacitance. This is referred to as crystal pulling. Refer to the "[How to Choose a Crystal for the MAX1470 RF Receiver](#)" application note for more details.
3. **Input matching and degeneration inductor:** The MAX1470 based design replaces C1, C2, C3, and L1 with a series 100pF cap and a series 68nH inductor. In addition, replace C5 with a 15nH inductor. The two new inductors will need to be positioned in place of the C3 and C5 capacitors. The values given in Table 1 are nominal but may need to be slightly tuned since they can be affected by the PC board traces.
4. **LC tank and mixer input.** L2, C6, and C8 will have to be changed to the values listed in Table 1. Once again, the values given are nominal but may need to be slightly tuned since they are affected by the PC

board traces.

Table 1 lists all the component changes. Although not required above, resistors R2 and R3 can be removed for a lower component count.

Table 1. Component differences between the TDA5200 and MAX1470 based designs

	Infineon Circuit	Maxim Circuit
Supply	5V	3.3V
IC	TDA5200/1	MAX1470
XTAL	13.2256MHz	6.6128MHz (433.92MHz), 4.7547MHz (315MHz)
R1	100K	Unchanged
R2	120K	None
R3	180K	None
L1	15nH	None
L2	10nH	15nH (433.92MHz) 27nH (315MHz)
C1	1pF	100pF
C2	4.7pF	None
C3	6.8pF	L=68nf (433.92MHz) 120nH (315MHz)
C4	100pF	Unchanged or 10nF
C5	47nF	L=15nH
C6	8.2pF	3.0pf (433.92MHz) 4.7pF (315MHz)
C7	100pF	Unchanged
C8	33pF	100pF
C9	100pF	Unchanged
C10	10nF	Unchanged
C11	10nF	Unchanged
C12	220pF	Unchanged
C13	47nF	Unchanged
C14	470pF	Unchanged
C15	15pF	Unchanged
C16	8.2pF	15pF

The resulting circuit is shown in **Figure 2**.

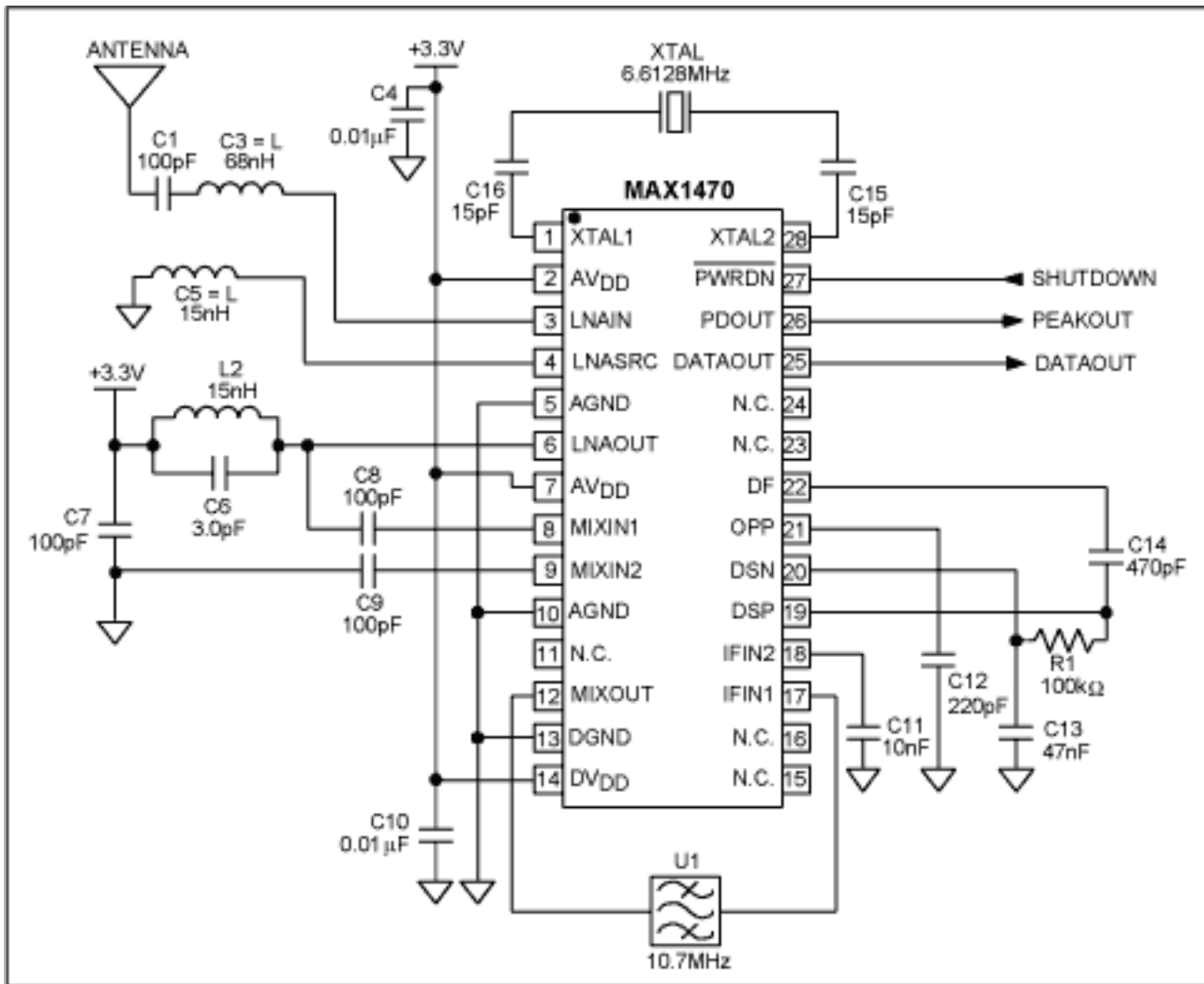

Figure 2. Typical MAX1470 based circuit (433.92MHz).

If the tank tuning and antenna matching are done correctly, you should expect the sensitivity to exceed -112dBm (315MHz), or -108dBm (433.92MHz). Image rejection is typically 53dB at 315MHz and 35dB at 433.92MHz.

Application note 1018: www.maxim-ic.com/an1018

More Information

For technical support: www.maxim-ic.com/support

For samples: www.maxim-ic.com/samples

Other questions and comments: www.maxim-ic.com/contact

Automatic Updates

Would you like to be automatically notified when new application notes are published in your areas of interest?
[Sign up for EE-Mail™.](#)

Related Parts

MAX1470: [QuickView](#) -- [Full \(PDF\) Data Sheet](#) -- [Free Samples](#)

AN1018, AN 1018, APP1018, Appnote1018, Appnote 1018

