

APPLICATION NOTE 1017

How to Choose a Quartz Crystal Oscillator for the MAX1470 Superheterodyne Receiver

Quartz crystals are available from various vendors in a variety of shapes and sizes, and can range widely in performance specifications. Some of these specifications include resonance frequency, resonance mode, load capacitance, series resistance, holder capacitance, and drive level. This application note helps in the understanding of these parameters, allowing the user to specify the crystal that is right for their application and one that will give the best results with the MAX1470 superheterodyne receiver circuit.

Quartz crystals are available from various vendors in a variety of shapes and sizes, and can range widely in performance specifications. Some of these specifications include resonance frequency, resonance mode, load capacitance, series resistance, holder capacitance, and drive level. Understanding these parameters will allow you to specify the crystal that is right for your application and one that will give you the best results with your MAX1470 circuit.

The equivalent circuit of a crystal is shown in **Figure 1**. It consists of the motional elements: resistor, R_s , inductor, L_m , and capacitor, C_m , and a shunt capacitance, C_o . The motional elements determine the series resonant frequency and the Q of the resonator. The shunt capacitance, C_o , is a function of the crystal electrodes, holder, and leads.

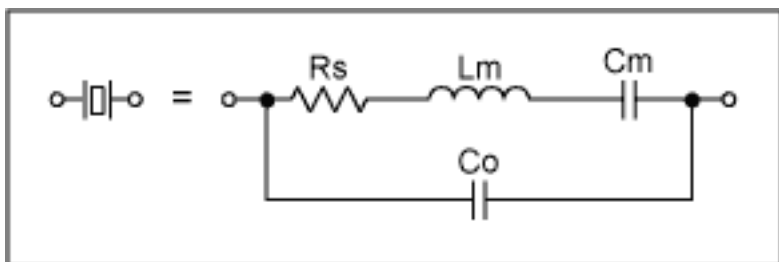

Figure 1. Crystal models.

The following details the key performance specifications.

Resonance Frequency

The crystal frequency to be specified is dependent on the frequency you're interested in receiving. Since the MAX1470 uses a 10.7MHz IF with low-side injection, the crystal frequency is given by (all units in MHz):

$$F_{XTAL} = \frac{F_{RF} - 10.7}{64}$$

For 315MHz applications, the crystal frequency is therefore, 4.7547MHz, while for 433.92MHz a 6.6128MHz crystal is needed. Only fundamental mode crystals should be specified (no overtones).

Resonance Mode

Crystals have two modes of resonance: series (the lower frequency of the two) and parallel (or anti-resonant, the higher of the two). All crystals exhibit both resonance modes at which they appear resistive in an oscillator circuit. At series resonance, the reactances of the motional capacitance, C_m , and inductance, L_m , are equal and opposite and the resistance is minimal. At the anti-resonance point, though, the resistance is maximum and the flow of current is minimal. The anti-resonance point is not used in oscillator designs.

A quartz crystal can be used to oscillate at any frequency between the series and anti-resonance frequencies by adding external components (usually capacitors). In the crystal industry this is referred to as the parallel frequency or mode. This frequency is above the series frequency but is below the true parallel resonance of the crystal (the anti-resonance point). **Figure 2** shows a typical crystal impedance versus frequency plot.

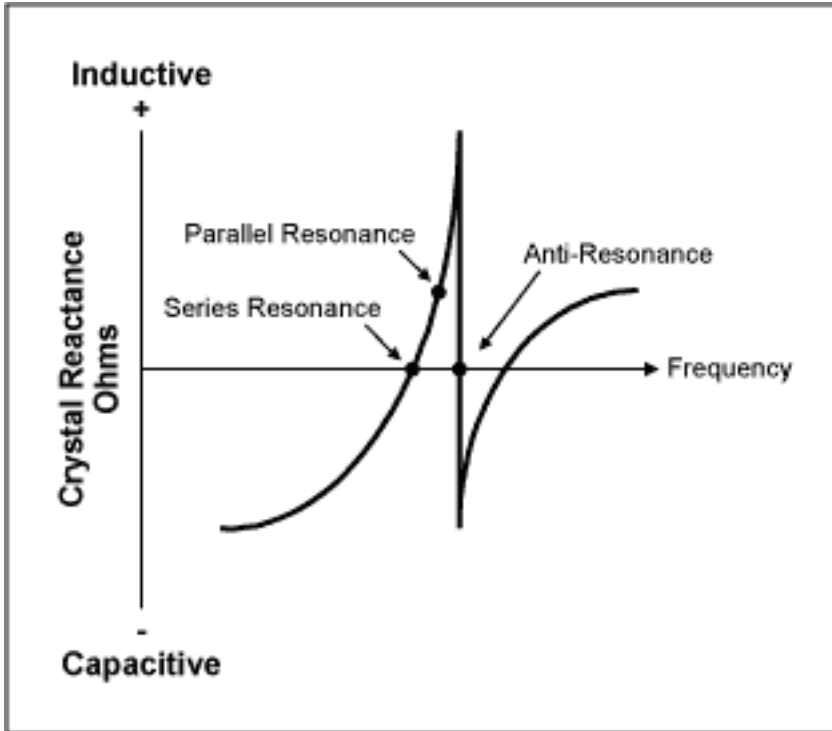

Figure 2. Crystal impedance versus frequency.

Load Capacitance and Pullability

Load capacitance is an important specification when using the parallel resonant oscillation mode. In this mode, the crystal's total reactance is slightly inductive and is in parallel with the oscillator's load capacitance, forming an LC tank circuit which determines the oscillator frequency. As the value of the load capacitance is changed, so does the output frequency. Therefore, the crystal vendor must know the load capacitance employed by the oscillator circuit so that it can be calibrated at the factory using the same load capacitance.

If a crystal designed to oscillate with a different load capacitance is used, the crystal is pulled away from its stated operating frequency, introducing an error in the reference frequency. Therefore, to pull the crystal back to its desired operating frequency, external capacitors are added to modify the load capacitance.

Figure 3 shows the crystal within the MAX1470EVKit circuit. In this circuit, C14 and C15 are series pulling capacitors, while C16 is a parallel pulling capacitor. Cevkit is the equivalent MAX1470, plus the evkit PCB stray capacitance. Cevkit is approximately 5pF.

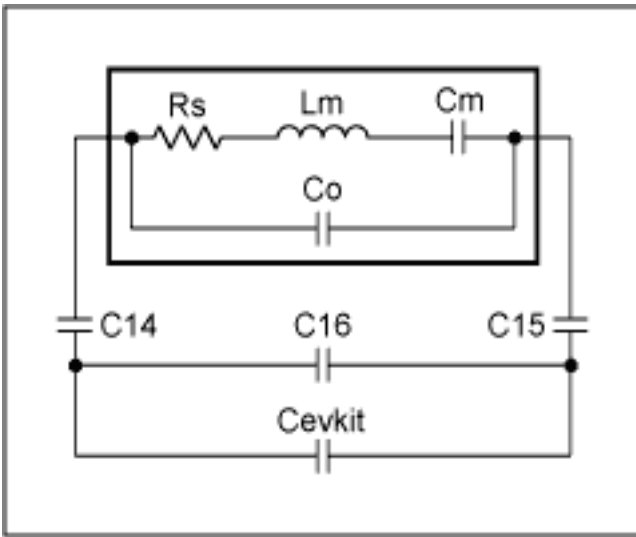

Figure 3. EVKit equivalent circuit.

Series pulling capacitors, will "speed up" the crystal, while a parallel capacitor will "slow" it down. Since Cevkit is equal to 5pF, if a crystal with a load capacitance of 5pF is used, it will oscillate at its intended frequency, and no additional capacitance is needed (C16 is left open, while C14 and C15 are shorted on the board). The evkit itself uses a 3pF load capacitance crystal, necessitating 2 x 15pF capacitors in series to speed it up. To calculate the capacitance values needed use:

$$\frac{1}{C_L} = \frac{1}{C_{14}} + \frac{1}{C_{15}} + \frac{1}{C_{evkit} + C_{16}}$$

In the case of the evkit, if the 2 series capacitors are not used, the 4.7547MHz crystal will actually oscillate at 4.7544MHz, causing the receiver to be tuned to 314.98MHz rather than 315.0MHz, an error of about 20kHz, or 60ppm.

Therefore, the key is to match the crystal's load capacitance required by using either series or parallel capacitors or even a combination of both (depending on the value of capacitors available). For example, a 1pF parallel capacitor is all that's needed for a 6pF load capacitance crystal (or the following combination: C14 = C15 = 27pF, C16 = 5pF).

Care must be exercised not to use too large values for C16, as it increases the current through the oscillator circuit, causing it to fail. **Figure 4** shows the relationship between parallel capacitance and oscillator current.

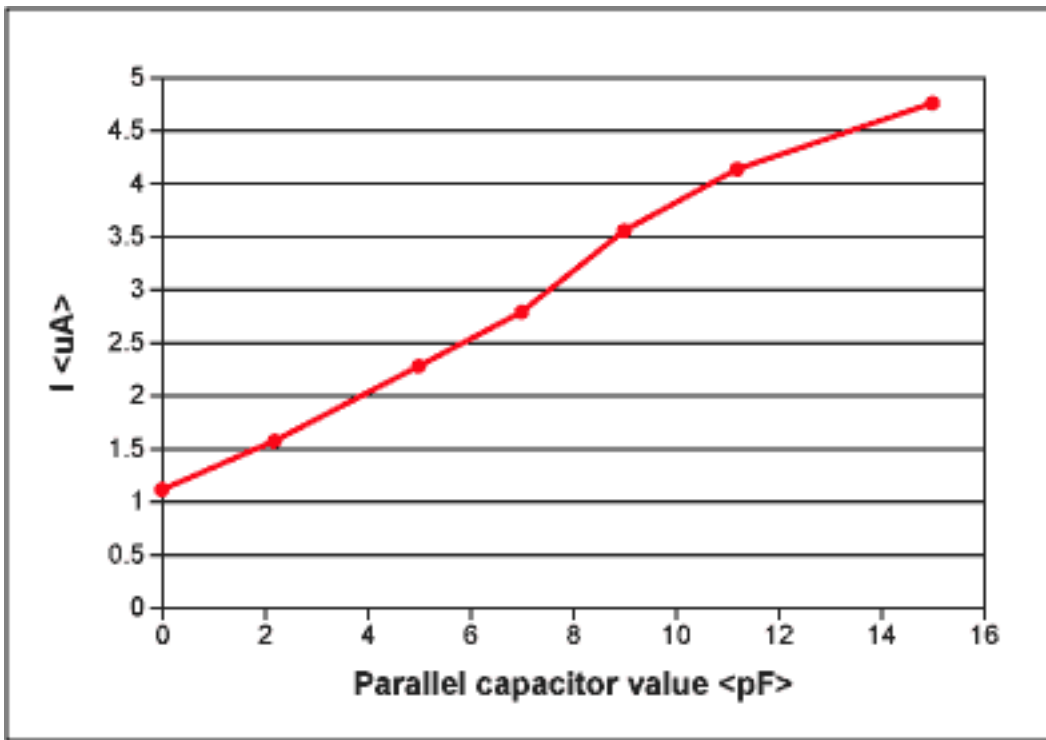

Figure 4. Crystal oscillator current vs. added parallel load capacitance.

On a custom PCB, if Cevkit is not known, it is possible to monitor the IF on a spectrum analyzer (make sure to use a DC blocking capacitor before inserting the signal into the spectrum analyzer), and then use the series and parallel capacitors to "tune" the IF back to 10.7MHz.

Series Resistance

A typical range of series resistance is 25Ω to 100Ω for most crystals. The crystal vendor usually characterizes this resistance and specifies maximum values for series resistance. Do not exceed 100Ω for the MAX1470 oscillator circuit.

Holder or Shunt Capacitance

This is the capacitance of the crystal electrodes, holder, and leads. Typical values range from 2pF to 7pF.

Drive Level

The power dissipated in the crystal must be limited or the quartz crystal can actually fail due to excessive mechanical vibration. Crystal characteristics also change with drive level due to non-linear behavior. The crystal vendor will specify the maximum drive level for a particular product line. Use crystals with drive levels in the $1\mu W$ range.

These specifications will allow you to specify a crystal that best fits the requirements of the MAX1470 oscillator circuit, which in turn will improve the overall performance.

Application Note 1017: <http://www.maxim-ic.com/an1017>

More Information

For technical questions and support: <http://www.maxim-ic.com/support>

For samples: <http://www.maxim-ic.com/samples>

Other questions and comments: <http://www.maxim-ic.com/contact>

Related Parts

MAX1470: [QuickView](#) -- [Full \(PDF\) Data Sheet](#) -- [Free Samples](#)

MAX1472: [QuickView](#) -- [Full \(PDF\) Data Sheet](#) -- [Free Samples](#)

MAX1473: [QuickView](#) -- [Full \(PDF\) Data Sheet](#) -- [Free Samples](#)

AN1017, AN 1017, APP1017, Appnote1017, Appnote 1017

Copyright © 2005 by Maxim Integrated Products

Additional legal notices: <http://www.maxim-ic.com/legal>