



APPLICATION NOTE 1013

The MAX2206/MAX2208 Power Detectors for CDMA Applications

Abstract: This article presents tables and graphs of data that support the application of the MAX2206 or MAX2208 power detectors in CDMA systems. Data is at 836MHz and 1880MHz. The MAX2208 has a 25dB dynamic range, while the MAX2206 has a 40dB range. Output voltage ripple with CDMA waveforms is explored. Extra filtering is used to reduce the ripple to $50mV_{p-p}$, while the response time becomes $350\mu s$.

Additional Information

- [Wireless Product Line Page](#)
- [Quick View Data Sheet for the MAX2206/MAX2207/MAX2208](#)
- [Applications Technical Support](#)

Introduction

Cellular telephone systems often rely on the control of transmitter output power to insure proper system operation and maximum capacity. This is especially true in CDMA-based systems. Maxim has introduced a family of integrated circuits (ICs) designed to accurately detect transmitter output power and allow accurate control. This application note presents application circuits and data for using the MAX2206 and MAX2208 with a CDMA modulated input signal. Data are presented for operation at 836MHz and 1880MHz. The MAX2206 and MAX2208 evaluation kits were used for gathering data on these parts.

General Description of the MAX2206 and MAX2208

The MAX2206 and MAX2208 are wideband (800MHz to 2GHz) power detectors that take an RF signal from a directional coupler and output a highly repeatable voltage. The output voltage increases monotonically with input power and is compensated for temperature and process shifts, reducing variation to less than $\pm 1dB$ at full input power (+15dBm) and $\pm 2.5dB$ at the lowest power. Both power detectors come in space-saving 2 x 2, 0.5mm-pitch ultra chip-scale packages (UCSP).

There are two main differences between the MAX2206 and MAX2208. The first variation is in the dynamic range. The MAX2206 has 40dB of dynamic range spanning from -25dBm up to +15dBm. The MAX2208's 25dB of dynamic range, from -10dBm to +15dBm, while being lower than the MAX2206, allows for reduced supply-current consumption.

An integrated filter is included in the MAX2208. This filter allows average-power detection, which is necessary when working with CDMA modulated signals. The MAX2206 does not have such a filter, and therefore requires an external filter to accurately detect such signals.

CDMA Application

A key parameter to consider when using a power detector in a CDMA application is the ripple noise on the output voltage. This noise appears on the output voltage because CDMA modulation produces a nonconstant amplitude envelope. System specifications determine the maximum acceptable ripple from the power detector. Using the on-chip filter of the MAX2208 may not meet this specification. In order to decrease ripple noise, a shunt

capacitor can be placed on the output of the IC. This capacitor increases the time constant of the output filter, thus decreasing the bandwidth of the lowpass filter and subsequently lessening the output ripple voltage. **Table 1** presents data taken from a MAX2208 with a 1500pF output capacitor.

Table 1. The MAX2208 Performance Data with a 1.5nF Output Capacitor

P_{IN} (dBm)	836MHz		1880MHz	
	V_{OUT} (mV)	Ripple Noise (mV _{P-P}) ¹	V_{OUT} (mV)	Ripple Noise (mV _{P-P}) ¹
15	1606	44	1643	49
13	1247	36	1291	35
11	965	29	997	29
9	741	23	765	24
7	562	19	577	20
5	427	16	439	17
3	325	15	335	15
1	245	14	254	13
-1	186	12	192	11
-3	141	12	146	10
-5	109	11	113	10
-7	86	11	89	10
-9	70	10	72	10
-11	59	10	60	10

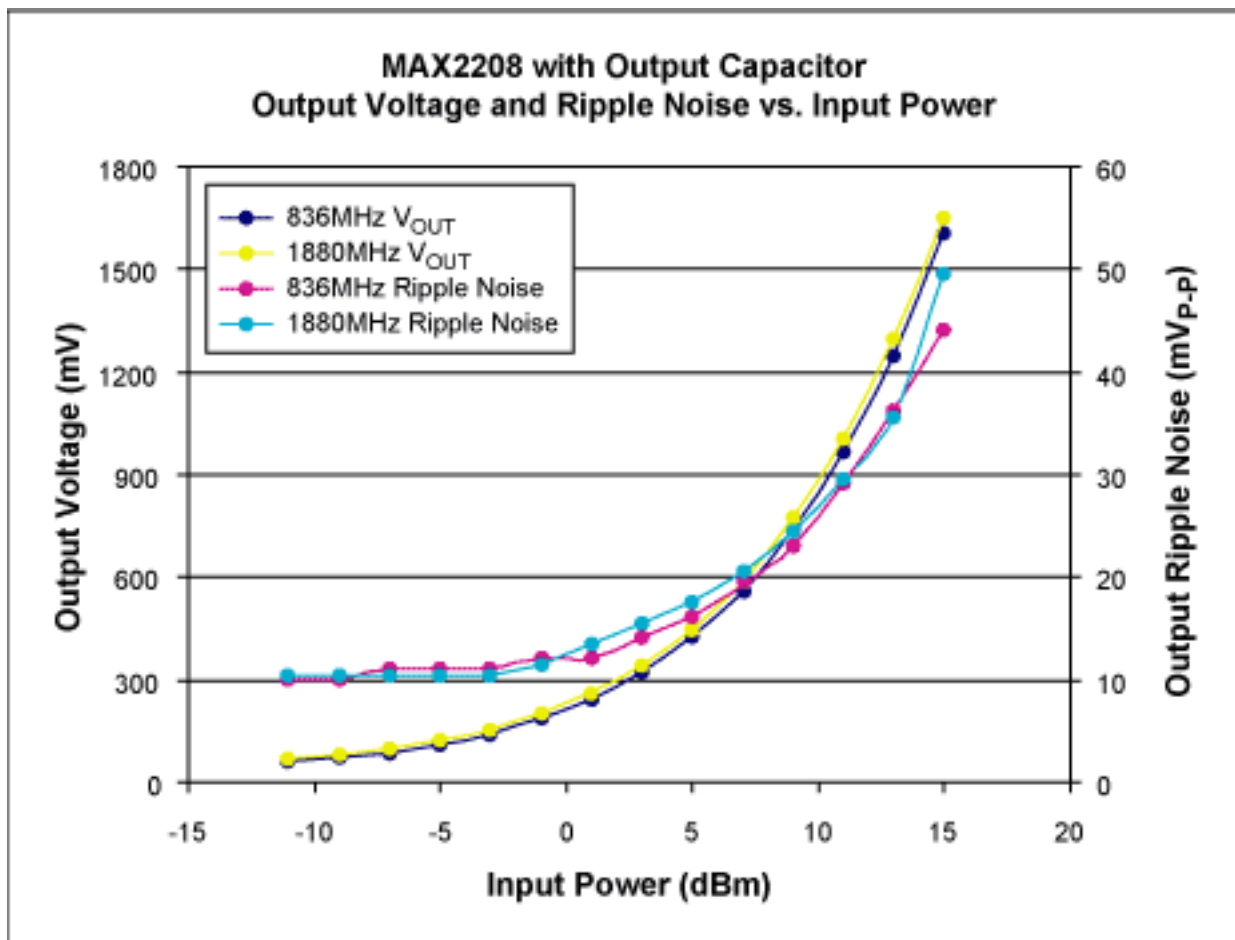

Figure 1. The MAX2208 performance data.

When using the MAX2206, there is no integrated output filter. To average the output voltage so that CDMA signals can be properly detected, an external lowpass filter composed of a resistor and a capacitor is added to the circuit's output pin. The filter bandwidth is reduced by increasing the values of the resistor and capacitor comprising the output filter. A narrower filter bandwidth reduces the ripple amplitude. Results from a typical implementation of the MAX2206 are presented in **Table 2**.

Table 2. The MAX2206 Performance Data with a 1.5k Ω Series Output Resistor and a 6.8nF Shunt Output Capacitor

P _{IN} (dBm)	836MHz		1880MHz	
	V _{OUT} (mV)	Ripple Noise (mV _{P-P}) ¹	V _{OUT} (mV)	Ripple Noise (mV _{P-P}) ¹
15	1558	47	1296	45
13	1264	37	1031	34
11	1036	29	818	27
9	856	23	651	21
7	717	19	523	17
5	613	16	426	14
3	535	13	354	12
1	476	11	299	11
-1	433	10	257	10
-3	415	10	228	10
-5	375	10	207	10
-7	349	10	190	10
-9	319	10	174	10
-11	283	10	158	10
-13	242	10	141	10
-15	200	10	122	10
-17	160	10	103	10
-19	126	10	85	10
-21	98	10	69	10

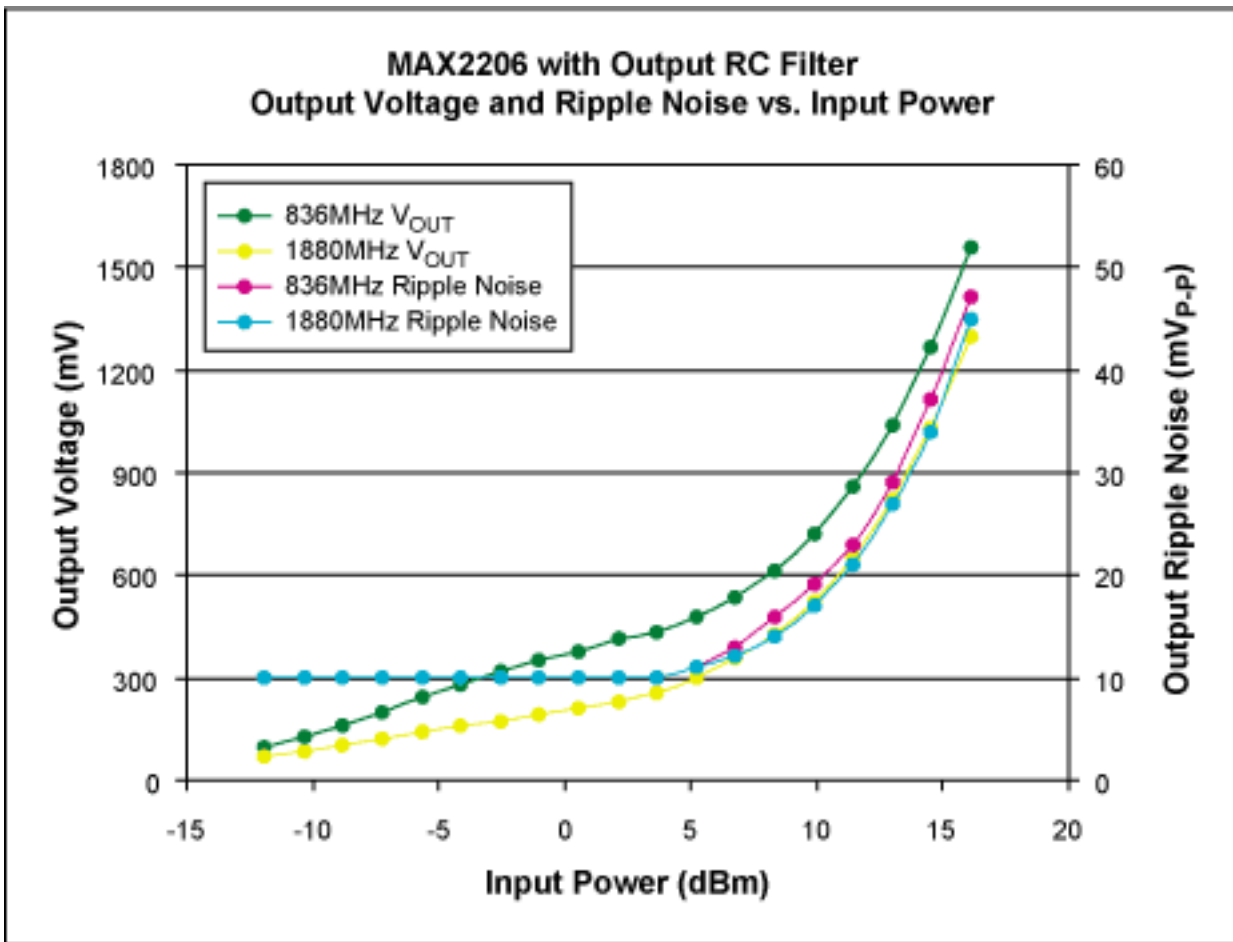

Figure 2. The MAX2206 performance data.

The reduction of ripple does not come without expense. The price paid is that of increased response time; there is a tradeoff which must be made between response time and ripple noise. The required response time of most CDMA systems is not very restraining, typically less than 500 μ s. Ripple noise can be reduced to within system specifications while still meeting this response time. For example, without any external filtering, the MAX2208 has a response time of 15 μ s. Adding an additional output capacitor to reduce maximum ripple noise to 50mV_{p-p} increases response time to 350 μ s.

Which Part Is Best for My Application?

The first step in answering this question is to determine the power range to be detected. The power range is determined by the RF power being sensed and the coupling value of the directional coupler. The greater the coupling numerical value, the lower the RF power delivered to the detector. High coupling values or wide dynamic range makes the MAX2206 the best choice, as it can detect 15dB lower power than the MAX2208.

The other factor distinguishing which part to use is the circuit board area that the power detector will occupy. The MAX2206 needs an extra resistor on the output, which increases the area occupied by the power detector. If space is a critical factor in the design, then the MAX2208 allows for a more compact design.

Measured Data

For the measurements in this application note, output component values were based upon design parameters of less than 500 μ s response time while achieving ripple noise of under 50mV_{p-p}. In order to decrease the output ripple in the MAX2208, a 1.5nF shunt capacitor was placed on the output (see **Figure 3**). For the MAX2206, an RC network consisting of a 15k Ω series resistor and a 6.8nF shunt capacitor was implemented (see **Figure 4**).

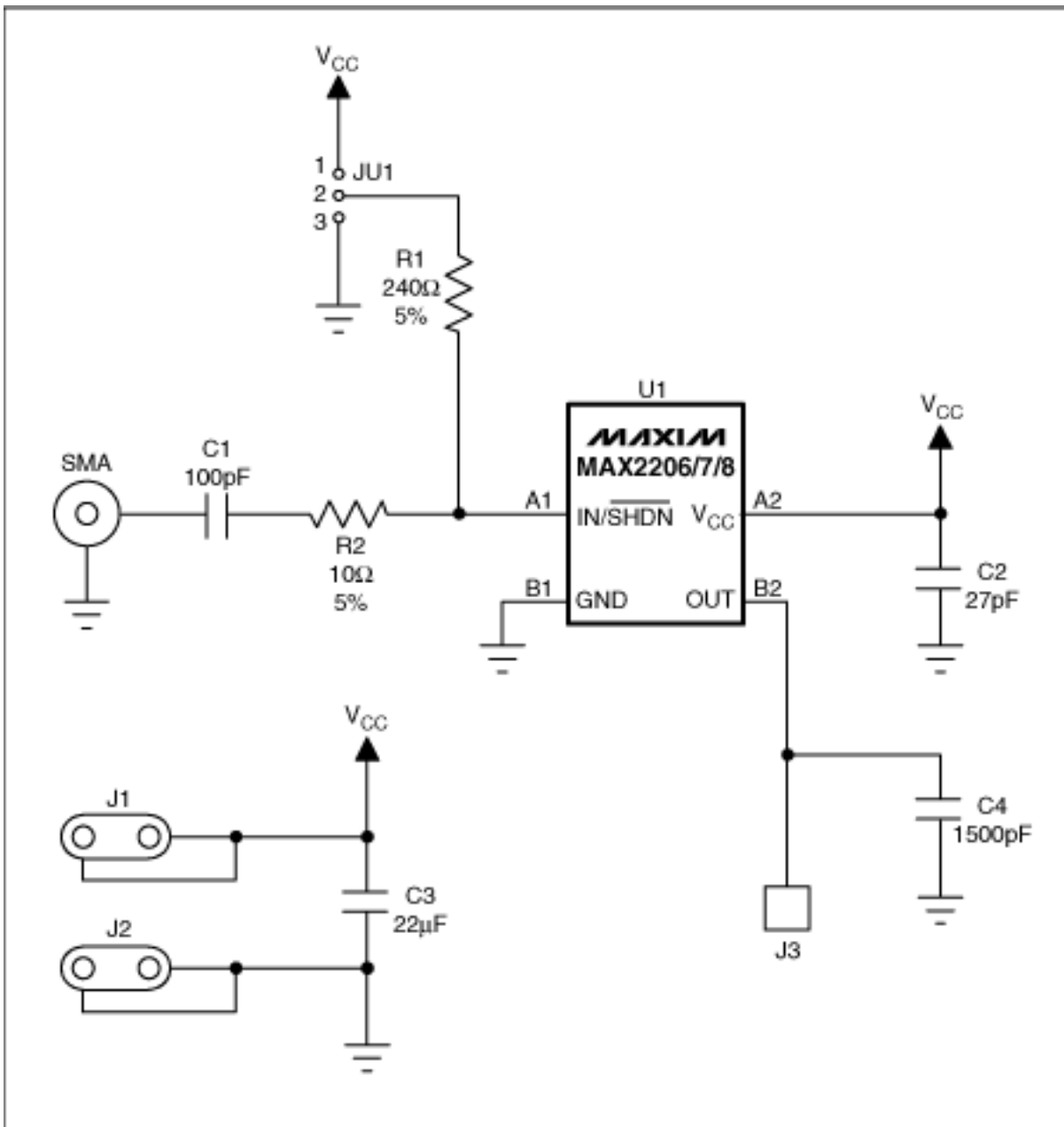

Figure 3. The MAX2208 evaluation kit schematic.

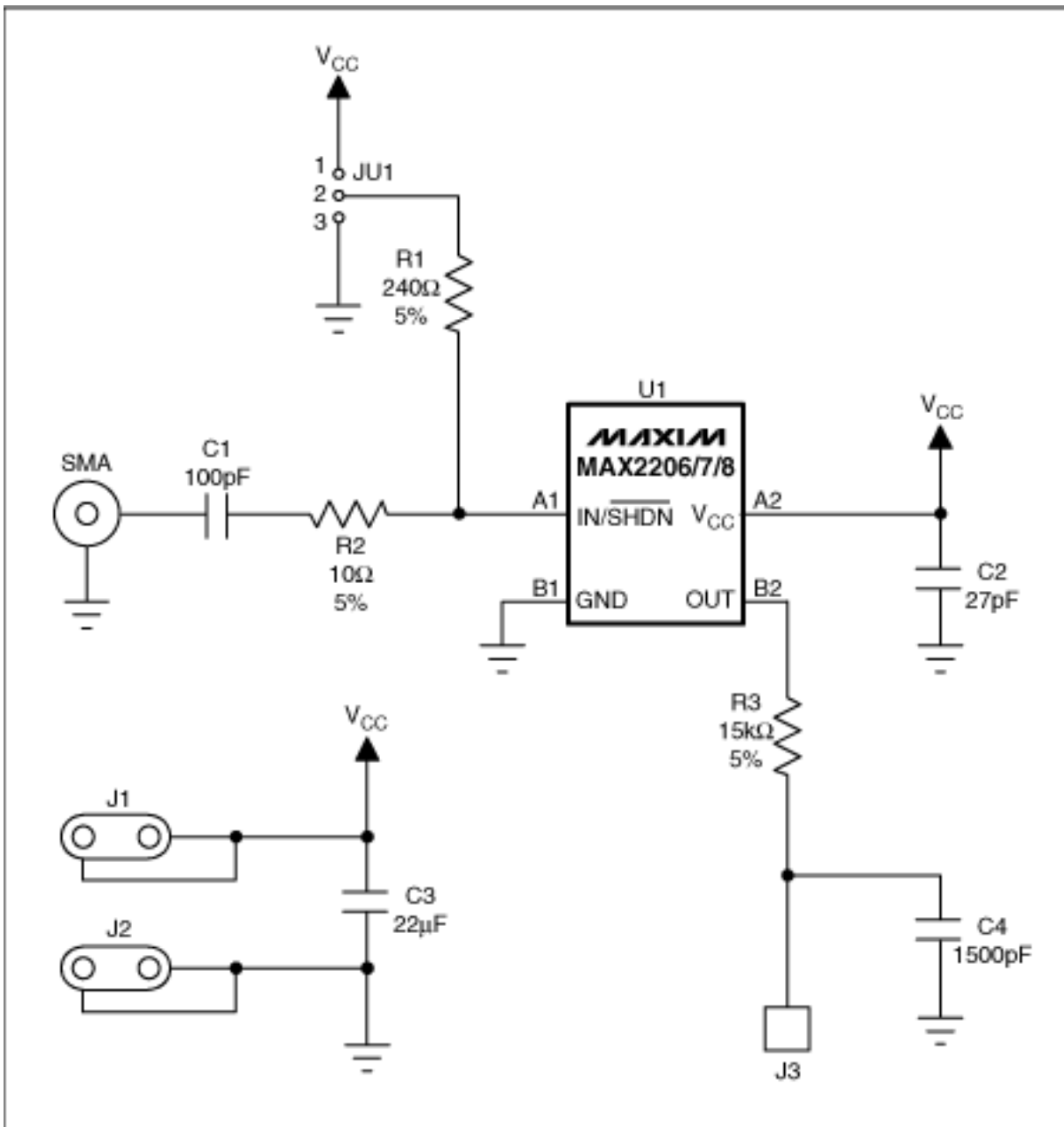

Figure 4. The MAX2206 evaluation kit schematic.

Response time for the MAX2208 with less than $50\text{mV}_{\text{p-p}}$ ripple noise was measured at $350\mu\text{s}$. For the MAX2206, response time was measured at $240\mu\text{s}$.

Input signal modulation: CDMAONE (IS95) Reverse Link, 1% PK-Avg = 3.9dB

Notes:
 In the test setup used, the noise floor for ripple noise measurements was $10\text{mV}_{\text{p-p}}$. Recorded values of $10\text{mV}_{\text{p-p}}$ are solely measurements of outside noise and are thus not indicative of the power detector's performance.

Application Note 1013: <http://www.maxim-ic.com/an1013>

More Information

For technical questions and support: <http://www.maxim-ic.com/support>

For samples: <http://www.maxim-ic.com/samples>

Other questions and comments: <http://www.maxim-ic.com/contact>

Related Parts

MAX2206: [QuickView](#) -- [Full \(PDF\) Data Sheet](#) -- [Free Samples](#)

MAX2208: [QuickView](#) -- [Full \(PDF\) Data Sheet](#) -- [Free Samples](#)

AN1013, AN 1013, APP1013, Appnote1013, Appnote 1013

Copyright © by Maxim Integrated Products

Additional legal notices: <http://www.maxim-ic.com/legal>