



## APPLICATION NOTE 100

# DS1670 Portable System Controller

*Abstract: This application note describes how to use the DS1670 Portable System Controller, a 3-wire serial interface real-time clock (RTC). The DS1670 supplies features that are targeted at portable (hand held) systems.*

## Features

There is an increasing trend in the industry today towards portable battery-operated products. These products typically require extremely small form factors and low power. The DS1670 Portable System Controller is designed to help the portable system designer in meeting these two requirements by integrating key functions typically needed in these systems while consuming very little power.

Key functions frequently required in portable products include a real time clock; nonvolatile RAM control to ensure that data is not lost in the event of a power-down or battery-fail; microprocessor monitoring to ensure that the microprocessor does not "run out of control"; and analog-to-digital converters for interfacing with external environmental sensors, battery monitoring, etc. The DS1670 Portable System Controller replaces as many as four separate integrated circuits by incorporating all of these functions in a single device. The DS1670 provides a very accurate real time clock, nonvolatile SRAM controller, microprocessor monitor, and 3-channel 8-bit analog-to-digital converter. Communication with the device is established through a simple 3-wire interface.

## Using the DS1670

The DS1670 can be directly interfaced with any microprocessor or microcontroller through a 3-wire serial interface. The serial interface gives the microprocessor access to the DS1670 registers, which consist of the Real Time Clock Registers, Control Register, Status Register, Watchdog Register, and ADC (Analog-to-Digital Converter) Register. **Figures 1** and **2** illustrate a block diagram and address map of the DS1670, respectively. The following paragraphs briefly describe the operation of the various components of the DS1670 as well as the functions of the various control and status registers. For more detailed information, please consult the DS1670 data sheet.

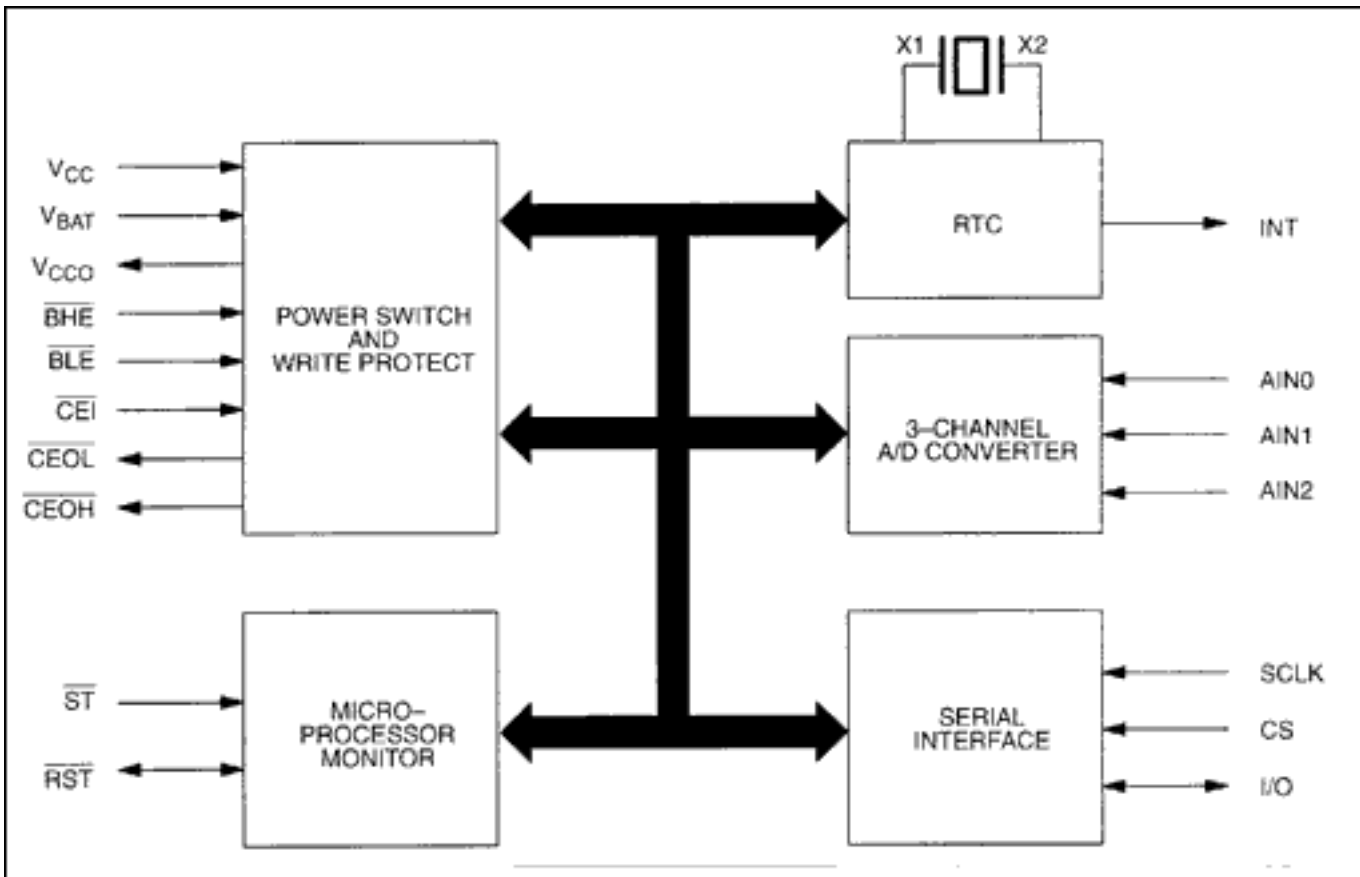

Figure 1. DS1670 block diagram.

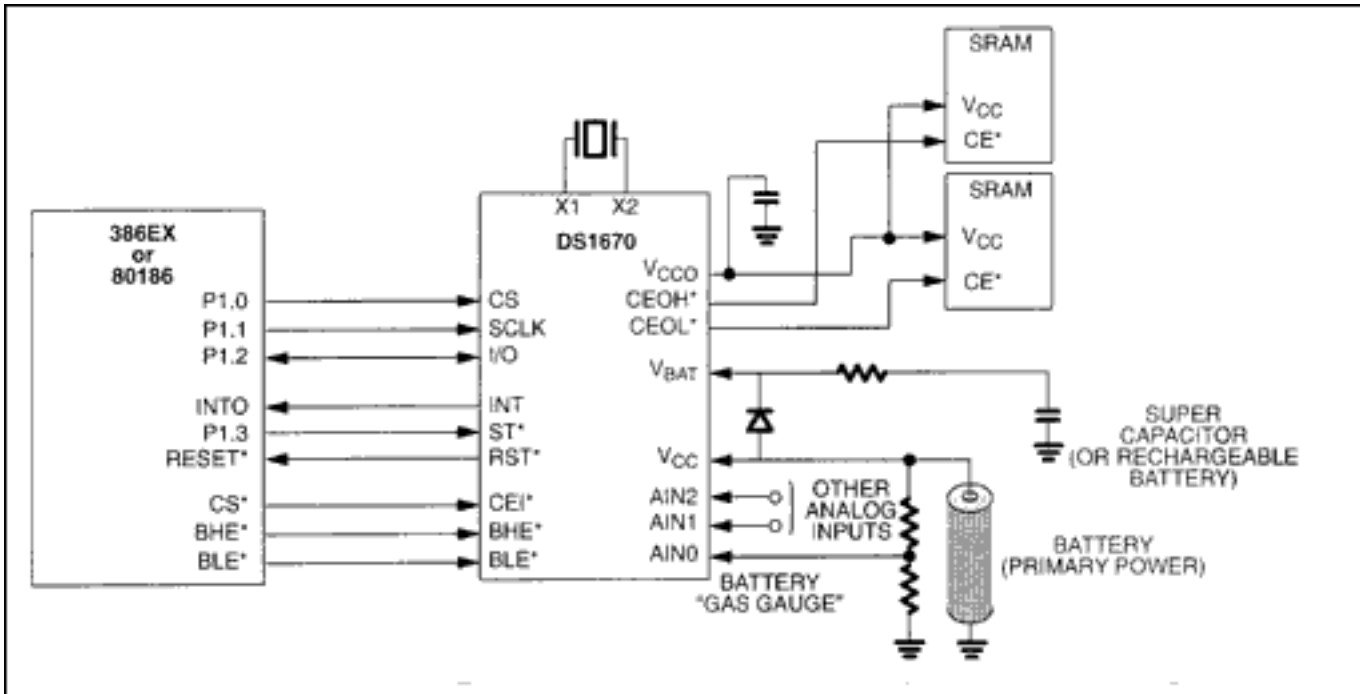

Figure 2. Typical application.

## Real Time Clock

The Real Time Clock (RTC) provides seconds, minutes, hours, day, date, month, and year information with leap year compensation. The RTC has a back-up power supply input ( $V_{BAT}$ ) that enables it to continue to keep time even when the primary supply connected to  $V_{CC}$  is removed. The RTC also provides an alarm interrupt which is

functional both when the DS1670 is powered by the system power supply or when in battery back-up operation. Functionality while in battery back-up operation allows the alarm to "wake up" a system that is powered down.

## Nonvolatile SRAM Control

The nonvolatile SRAM controller of the DS1670 provides two important functions. First, it ensures a constant uninterrupted power supply to the system SRAMs. This is provided by the  $V_{CC}$  Output pin ( $V_{CCO}$ ).  $V_{CCO}$  is internally connected to  $V_{CC}$  when  $V_{CC}$  is within nominal limits. However, when  $V_{CC}$  is below nominal limits,  $V_{CCO}$  is connected to the power source connected to  $V_{BAT}$  (typically a lithium battery, rechargeable battery, or super capacitor). The second important feature of the nonvolatile controller is that it gates the chip enable signals to the SRAMs. This ensures that the microprocessor can access the SRAMs only when the primary power supply is within nominal limits, thus eliminating the corruption of data during power transients. It should also be noted that the DS1670 provides nonvolatile control for two separate SRAMs. The two inputs from the microprocessor are Byte High Enable (active-low BHE) and Byte Low Enable (active-low BLE). These inputs correspond to the two output Chip Enable Output High (active-low CEOH) and Chip Enable Output Low (active-low CEOL).

## Microprocessor Monitor

The microprocessor monitor circuitry of the DS1670 provides three basic functions:

1. A precision temperature-compensated reference and comparator circuit monitors the status of  $V_{CC}$ . When an out-of-tolerance condition occurs, an internal power fail signal is generated which forces the reset to the active state. When  $V_{CC}$  returns to an in-tolerance condition, the reset signals are kept in the active state for 250 ms to allow the power supply and processor to stabilize.
2. Pushbutton reset control: The DS1670 debounces a pushbutton input and guarantees an active reset pulse width of 250 ms.
3. Watchdog timer: The DS1670 has an internal timer that forces the reset signals to the active state if the strobe input is not driven low prior to watchdog time-out.

## Analog-to-Digital Converter

The DS1670 also provides a 3-channel 8-bit successive approximation analog-to-digital converter. The converter has an internal 2.55 volt (typical) reference voltage generated by an on-board band-gap circuit. The A/D converter is monotonic (no missing codes) and has an internal analog filter to reduce high frequency noise.

An A/D conversion is the process of assigning a digital code to an analog input voltage. This code represents the input value as a fraction of the full scale voltage (FSV) range. Thus the FSV range is then divided by the A/D converter into 256 codes (8 bits). The FSV range is bounded by an upper limit equal to the reference voltage and the lower limit, which is ground. The DS1670 has a FSV of 2.55V (typically) which provides a resolution of 10 mV. An input voltage equal to the reference voltage converts to FFh while an input voltage equal to ground converts to 00h. The relative linearity of the A/D converter is  $\pm 0.5$  LSB.

The analog input (AIN0, AIN1, or AIN2) for an analog-to-digital conversion is selected by the condition of the Analog Input Select (AIS) bits in the Control Register. Conversions occur every 10 ms and the result is placed in the ADC Register.

## Typical Application

**Figure 3** illustrates a typical application using the DS1670. In this application, the DS1670 is shown interfacing with a 386EX or 80186 microprocessor (microprocessors designed with embedded applications in mind). Communication between the microprocessor and the DS1670 is accomplished easily through three port pins (P1.0-P1.2) which are connected to the 3-wire serial interface pins of the DS1670 Serial Clock (SCLK), Chip

Select (active-low CS), and serial input/output (I/O). This serial interface provides access to the real time clock, ADC, control, and status registers of the DS1670.

	BIT7					BIT0
00	0	10 SECONDS			SECONDS	
01	0	10 MINUTES			MINUTES	
02	0	12 / 24	10 HR / A/P	10 HR	HOURS	
03	0	0	0	0	0	DAY
04	0	0	10 DATE		DATE	
05	0	0	0	10 MO.	MONTH	
06	10 YEAR			YEAR		
07	M	10 SEC ALARM			SECONDS ALARM	
08	M	10 MIN ALARM			MINUTES ALARM	
09	M	12 / 24	10 HA / A/P	10 HA	HOUR ALARM	
0A	M	0	0	0	DAY ALARM	
0B	CONTROL REGISTER					
0C	STATUS REGISTER					
0D	WATCHDOG REGISTER					
0E	ADC REGISTER					
0F	RESERVED					
7F						

Figure 3. DS1670 address map.

## Nonvolatile SRAM Control

The DS1670 also provides nonvolatile control of external SRAMs in this circuit example. The Chip Select (active-low CS), Byte High Enable (active-low BHE), and Byte Low Enable (active-low BLE) outputs of the

microprocessor are *gated* through the DS1670 to its Chip Enable Output Low (active-low CEOL) and chip Enable Output High (active-low CEOH) output pins. The active-low CEOL and CEOH pins can be driven to the active state only when  $V_{CC}$  is within nominal limits ( $>2.88V$ ) thus preventing the system from receiving or writing corrupted data. Note that the structure of the SRAM access controller allows the microprocessor to access data in worldwide format (16 bits wide by enabling active-low CEOL and active-low CEOH simultaneously) or byte-wide format (8-bit wide by enabling either active-low CEOL or active-low CEOH).

Power to the SRAMs is provided from the  $V_{CCO}$  pin of the DS1670. When  $V_{CC}$  is within nominal limits (greater than 2.7 volts typical),  $V_{CCO}$  is internally connected to  $V_{CC}$ . However, when  $V_{CC}$  goes below nominal limits,  $V_{CCO}$  is internally connected to  $V_{BAT}$ , thus ensuring that the SRAM data is maintained in the event of a primary power supply failure.  $V_{BAT}$  is typically connected to a lithium battery, rechargeable battery, or super capacitor. Figure 3 illustrates  $V_{BAT}$  connected to a super capacitor. The super capacitor is charged whenever the power source connected to  $V_{CC}$  is a diode drop above  $V_{BAT}$  plus the voltage drop across resistor R1. R1 is used to decrease the charge current to the super capacitor. Note that in this application, the primary power source connected to  $V_{CC}$  is a battery. This could be a rechargeable battery pack or perhaps a series of AA cells. Regardless of the type of battery used, the DS1670 allows the battery to be changed without the loss of important data. Depending on the size and type of super capacitor or battery connected to  $V_{BAT}$ , the data will be saved from several hours to several years without replacing the main system battery. It should be noted also that when using a super capacitor, the limiting factor is often the internal leakage of the capacitor itself. In other words, the battery back-up current consumed by the DS1670 and SRAMs is negligible compared to the internal leakage of the capacitor.

## Microprocessor Monitoring

The illustrated typical application also takes advantage of the microprocessor monitoring features of the DS1670. The active-low RST of the DS1670 is connected to the active-low RESET pin of the microprocessor. The DS1670 will generate a reset signal if  $V_{CC}$  goes out of the nominal limits or if the watchdog timer is allowed to expire.

Toggling the strobe (active-low ST) input before the watchdog timer expires will keep the watchdog from generating a reset. The watchdog timer can be disabled or programmed by the user to be 250ms, 500ms, or 1000ms. It is also possible to connect the active-low RST pin to a momentary pushbutton switch to allow a manual reset of the system. In this type of application the active-low RST pin will produce a 250ms active reset after being momentarily grounded by an external momentary switch.

## Real Time Clock

Another important feature of the DS1670 is the Real Time Clock (RTC). The RTC provides the system with seconds, minutes, hours, day, date, month, and year information. The accuracy of the clock is typically  $\pm 1$  minute per month at room temperature. An especially powerful function of the RTC is the alarm. The alarm gives the user flexibility to program events at a specific time of the day. The DS1670 can be programmed to generate a single alarm or, through the use of its alarm mask bits, can generate an alarm once every second, minute, hour, or day. Added flexibility is provided in that the alarm is functional both when the device is powered by  $V_{CC}$  or when powered by  $V_{BAT}$ . Generating an alarm while powered by  $V_{BAT}$  is especially useful because this allows the DS1670 to "wake up" a sleeping system. For example, a portable data logger may need to collect data once every hour. This system could be placed in a low power "sleep mode" when idle. The alarm could be used to "wake up" the system at the appropriate time to collect data. After the collection is completed, software could place the system back into sleep mode where it would remain until the next alarm interrupt.

## Analog-to-Digital Converter

The DS1670 also has a 3-channel 8-bit analog-to-digital converter. In our typical application example, one input of the ADC is used as a battery "gas gauge." This input samples the voltage on the primary power supply battery, which is first reduced through a voltage divider circuit. The microprocessor monitors this voltage and

generates a low battery warning if the voltage falls below a specified threshold, thus signaling the end user that the battery needs to be changed. The additional ADC inputs could be interfaced with environmental sensors or other analog signals.

## Low Power

The functional features of the DS1670 are certainly a great benefit to many system designers, but equally important in portable systems is low power to ensure long battery life. It is probable that the majority of the time the DS1670 will sit idle in a powered-up system. In this type of standby operation, the DS1670 will consume a maximum of 100 $\mu$ A (200 $\mu$ A maximum if the analog-to-digital converter is enabled). During active operation, when the 3-wire interface is being driven, the DS1670 will typically consume 5mA (10mA maximum). The lowest power mode of the device is when the primary power supply is removed and the device is being powered by  $V_{BAT}$ . In this mode, the device typically consumes 300nA (500nA maximum).

## Summary

Overall, it has been shown that the DS1670 Portable System Controller provides many of the functions necessary in battery backed portable products. The integration of these features onto a single piece of silicon replaces as many as four separate integrated circuits and is available in an extremely small 20-pin TSSOP package. The DS1670 is also ideally suited for battery backed products because of its low power consumption, particularly when the device is in standby or battery backed mode.

---

Application Note 100: <http://www.maxim-ic.com/an100>

### More Information

For technical questions and support: <http://www.maxim-ic.com/support>

For samples: <http://www.maxim-ic.com/samples>

Other questions and comments: <http://www.maxim-ic.com/contact>

### Related Parts

DS1670: [QuickView](#) -- [Full \(PDF\) Data Sheet](#) -- [Free Samples](#)

DS1673: [QuickView](#) -- [Full \(PDF\) Data Sheet](#) -- [Free Samples](#)

DS1677: [QuickView](#) -- [Full \(PDF\) Data Sheet](#) -- [Free Samples](#)

AN100, AN 100, APP100, Appnote100, Appnote 100

Copyright © by Maxim Integrated Products

Additional legal notices: <http://www.maxim-ic.com/legal>